



# **AMBIENT 2020**

The Tenth International Conference on Ambient Computing, Applications,  
Services and Technologies

ISBN: 978-1-61208-814-3

October 25 - 29, 2020

## **AMBIENT 2020 Editors**

Oana Dini, IARIA, EU/USA

Navid Shaghghi, Santa Clara University, USA

# AMBIENT 2020

## Forward

The Tenth International Conference on Ambient Computing, Applications, Services and Technologies (AMBIENT 2020), held on October 22-29, 2020, continued a series of events devoted to a global view on ambient computing, services, applications, technologies and their integration.

On the way for a full digital society, ambient, sentient and ubiquitous paradigms lead the torch. There is a need for behavioral changes for users to understand, accept, handle, and feel helped within the surrounding digital environments. Ambient comes as a digital storm bringing new facets of computing, services and applications. Smart phones and sentient offices, wearable devices, domotics, and ambient interfaces are only a few of such personalized aspects. The advent of social and mobile networks along with context-driven tracking and localization paved the way for ambient assisted living, intelligent homes, social games, and telemedicine.

The conference had the following tracks:

- Ambient devices, applications and systems
- Ambient services, technology and platforms
- Ambient Environments for Assisted Living and Virtual Coaching
- User Friendly Interfaces

We take here the opportunity to warmly thank all the members of the AMBIENT 2020 technical program committee, as well as all the reviewers. The creation of such a high quality conference program would not have been possible without their involvement. We also kindly thank all the authors that dedicated much of their time and effort to contribute to AMBIENT 2020. We truly believe that, thanks to all these efforts, the final conference program consisted of top quality contributions.

We also gratefully thank the members of the AMBIENT 2020 organizing committee for their help in handling the logistics and for their work that made this professional meeting a success.

We hope that AMBIENT 2020 was a successful international forum for the exchange of ideas and results between academia and industry and to promote further progress in the field of ambient computing, applications, services and technologies.

### **AMBIENT 2020 Steering Committee**

Lorena Parra Boronat, Instituto Madrileño de Investigación y Desarrollo Rural, Agrario y Alimentario and Universitat Politecnica de Valencia, Spain

Yuh-Jong Hu, National Chengchi University-Taipei, Taiwan (ROC)

Jerry Chun-Wei Lin, Western Norway University of Applied Sciences, Bergen, Norway

Kenji Suzuki, Tokyo Institute of Technology, Japan

Valerie Camps, Paul Sabatier University - IRIT, Toulouse, France

**AMBIENT 2020 Publicity Chair**

Daniel Andoni Basterrechea, Universitat Politecnica de Valencia, Spain

## **AMBIENT 2020**

### **COMMITTEE**

#### **AMBIENT Steering Committee**

Lorena Parra Boronat, Instituto Madrileño de Investigación y Desarrollo Rural, Agrario y Alimentario and Universitat Politecnica de Valencia, Spain

Yuh-Jong Hu, National Chengchi University-Taipei, Taiwan (ROC)

Jerry Chun-Wei Lin, Western Norway University of Applied Sciences, Bergen, Norway

Kenji Suzuki, Tokyo Institute of Technology, Japan

Valerie Camps, Paul Sabatier University - IRIT, Toulouse, France

#### **AMBIENT 2020 Publicity Chair**

Daniel Andoni Basterrechea, Universitat Politecnica de Valencia, Spain

#### **AMBIENT 2020 Technical Program Committee**

Anas Abouelkalam, Cadi Ayyad University - ENSA Marrakesh, Morocco

Hassan Badir, Abdelmalek Essaâdi University, Morocco

Ayoub Bahnasse, ENSAM Casablanca - University Hassan II of Casablanca, Morocco

Maxim Bakaev, Novosibirsk State Technical University, Russia

Rachid Beghdad, Bejaia University, Algeria

Siham Benhadou, National School of Electricity and Mechanics, Casablanca (ENSEM-Casablanca), Morocco

David Bouck-Standen, Kingsbridge Research Center, UK

Valérie Camps, IRIT - Universite Paul Sabatier, France

Albert M. K. Cheng, University of Houston, USA

Mohammad Javad Darvishi, University of Montreal, Canada

Mohamed El Khaili, Université Hassan II de Casablanca, Morocco

Larbi Esmahi, Athabasca University, Canada

Marco Furini, University of Modena and Reggio Emilia, Italy

Valentina Gatteschi, Politecnico di Torino, Italy

Barbara Guidi, University of Pisa, Italy

Maki Habib, American University in Cairo, Egypt

Ileana Hamburg, Institut Arbeit und Technik, Germany

Jean Hennebert, iCoSys Institute | University of Applied Sciences HES-SO, Fribourg, Switzerland

Tzung-Pei Hong, National University of Kaohsiung, Taiwan

Yuh-Jong Hu, National Chengchi University, Taiwan

Kristina G. Kapanova, Trinity College, Dublin, Ireland

Adam Krzyzak, Concordia University, Canada

Markus Kucera, Ostbayerische Technische Hochschule Regensburg (OTH Regensburg), Germany

Lenka Lhotska, Czech Technical University in Prague, Czech Republic

Jerry Chun-Wei Lin, Western Norway University of Applied Sciences, Bergen, Norway

José Luís Silva, ITI/LARSYS & Instituto Universitário de Lisboa (ISCTE-IUL), ISTAR-IUL, Portugal

Johann M. Marquez-Barja, University of Antwerp - imec, Belgium

Walid Merrad, Univ. Polytechnique Hauts-de-France, France  
Ivan Miguel Pires, Instituto de Telecomunicações | Universidade da Beira Interior, Covilhã, Portugal  
Khalid Nafil, University Mohammed V, Morocco  
Keith V. Nesbitt, University of Newcastle, Australia  
Gerhard Nussbaum, Kompetenznetzwerk Informationstechnologie zur Förderung der Integration von Menschen mit Behinderungen (KI-I), Austria  
Brendan O'Flynn, Tyndall Microsystems | University College Cork, Ireland  
Eva Oliveira, 2Ai - EST -Polytechnic Institute of Cavado and Ave, Portugal  
Salome Oniani, Georgian Technical University, Georgia  
Lorena Parra Boronat, Instituto Madrileño de Investigación y Desarrollo Rural, Agrario y Alimentario // Universitat Politecnica de Valencia, Spain  
Jorge Peña Queralta, Turku Intelligent Embedded and Robotic Systems (TIERS) Group - University of Turku, Finland  
Sigmundo Preissler Jr., Universidade do Contestado, Brazil  
Diego Reforgiato Recupero, University of Cagliari, Italy  
Fernando Reinaldo Ribeiro, Polytechnic Institute of Castelo Branco, Portugal  
Valérie Renault, CREN Laboratory - Le Mans University, France  
Daniele Riboni, University of Cagliari, Italy  
Michele Risi, University of Salerno, Italy  
Carsten Röcker, FraunhoferIOSB-INA, Germany  
Claudio Rossi, LINKS Foundation, Italy  
Michele Ruta, Politecnico di Bari, Italy  
Khair Eddin Sabri, The University of Jordan, Jordan  
José Iván San José Vieco, University of Castilla-La Mancha, Spain  
Peter Schneider-Kamp, University of Southern Denmark, Denmark  
Floriano Scioscia, Polytechnic University of Bari, Italy  
Antonio Sgorbissa, Università di Genova, Italy  
Navid Shaghghi, Santa Clara University, USA  
Riaz Ahmed Shaikh, King Abdulaziz University, KSA  
Ahmed Shehata, University of Alberta, Canada  
Sheng Shen, University of Illinois at Urbana-Champaign, USA  
Carine Souveyet, Université Paris 1 Panthéon-Sorbonne, France  
Daniela Elisabeth Ströckl, Carinthia University of Applied Science - Institute for Applied Research on Ageing (IARA), Austria  
Mu-Chun Su, National Central University, Taiwan  
Kenji Suzuki, Tokyo Institute of Technology, Japan  
Yeshasvi Tirupachuri, Dynamic Interaction Control group of Italian Institute of Technology, Genoa, Italy  
Markku Turunen, Tampere University, Finland  
Thomas Waas, Ostbayerische Technische Hochschule Regensburg (OTH Regensburg), Germany  
Marcin Wozniak, Silesian University of Technology, Poland  
Xiang Xiao, Google Inc., USA  
Kin-Choong Yow, University of Regina, Canada

## Copyright Information

For your reference, this is the text governing the copyright release for material published by IARIA.

The copyright release is a transfer of publication rights, which allows IARIA and its partners to drive the dissemination of the published material. This allows IARIA to give articles increased visibility via distribution, inclusion in libraries, and arrangements for submission to indexes.

I, the undersigned, declare that the article is original, and that I represent the authors of this article in the copyright release matters. If this work has been done as work-for-hire, I have obtained all necessary clearances to execute a copyright release. I hereby irrevocably transfer exclusive copyright for this material to IARIA. I give IARIA permission to reproduce the work in any media format such as, but not limited to, print, digital, or electronic. I give IARIA permission to distribute the materials without restriction to any institutions or individuals. I give IARIA permission to submit the work for inclusion in article repositories as IARIA sees fit.

I, the undersigned, declare that to the best of my knowledge, the article does not contain libelous or otherwise unlawful contents or invading the right of privacy or infringing on a proprietary right.

Following the copyright release, any circulated version of the article must bear the copyright notice and any header and footer information that IARIA applies to the published article.

IARIA grants royalty-free permission to the authors to disseminate the work, under the above provisions, for any academic, commercial, or industrial use. IARIA grants royalty-free permission to any individuals or institutions to make the article available electronically, online, or in print.

IARIA acknowledges that rights to any algorithm, process, procedure, apparatus, or articles of manufacture remain with the authors and their employers.

I, the undersigned, understand that IARIA will not be liable, in contract, tort (including, without limitation, negligence), pre-contract or other representations (other than fraudulent misrepresentations) or otherwise in connection with the publication of my work.

Exception to the above is made for work-for-hire performed while employed by the government. In that case, copyright to the material remains with the said government. The rightful owners (authors and government entity) grant unlimited and unrestricted permission to IARIA, IARIA's contractors, and IARIA's partners to further distribute the work.

## Table of Contents

BOxy: A Cost-Effective Blood Oximeter <i>Beau Hsia, Derrick Wang, Navid Shaghaghi, and Zhiwen Zhang</i>	1
GluMo: A Noninvasive Blood Glucose Monitor <i>Ben Tan, Peter Ferguson, Teddy Nguyen, Hannah Albright, Navid Shaghaghi, and Zhiwen Zhang</i>	5
A Systematic Review of Ambient Display Modalities, Physical Forms and Interactivity <i>Ben Shelton and Keith Nesbitt</i>	9
Social Interactions of Artificial Ventilated Patients in Intensive Care – an Example of a Monitoring System <i>Jan Hendrik Rohl, Alexander Gerka, Rebecca Diekmann, and Andreas Hein</i>	16
Effects of Indoor Environmental Quality on Concentration <i>Salla Muuraiskangas, Heidi Simila, Johanna Kallio, Pauli Rasanen, and Kaisa Vehmas</i>	22
Long-Range Data Transmission for Online Water Quality Monitoring of the Tembling River in Rural Areas of Pahang, Malaysia <i>Norashikin M. Thamrin, Nik Nor Liyana Nik Ibrahim, Mohamad Farid bin Misnan, and Navid Shaghaghi</i>	28
SU 2.0: A Marketable Low-Power Wireless Sensing Unit for Hydration Automation <i>Navid Shaghaghi, Nicholas Kniveton, Jesse Mayer, Will Tuttle, and Peter Ferguson</i>	33

# BOxy: A Cost-Effective Blood Oximeter

Beau Hsia, Derrick Wang, Navid Shaghghi, and Zhiwen Zhang

Ethical, Pragmatic, and Intelligent Computing (EPIC) Laboratory

Santa Clara University, Santa Clara, California, USA

{bhsia, dwang1, nshaghghi, zzhang}@scu.edu

**Abstract**—In third-world countries, there are efforts that push for the increased availability of pulse oximeters for monitoring critical health conditions. Currently, it costs African hospitals 500 USD to replace their current oximeters, and 250 USD to repair small malfunctions, due to the outrageously high shipping costs for both the machine and its spare parts. There is a great need for oximeters that are cost effective, easy to maintain and repair, portable, and convenient. With the proliferation of the Internet of Things (IoT) these requirements can easily be met. However, the benefits of IoT have not yet reached critical mass in rural, isolated, or impoverished parts of the world. Therefore, even though the recent years have seen a plethora of wireless clip-on fingertip pulse oximeters on the market, the cost and reliability on a Bluetooth connection with a cellphone are still considerable and sometimes prohibitive factors. At the time of this writing, simple yet reliable SPO2 sensors exist for around 2 USD yet the cheapest pulse oximeter with Bluetooth capability is around 30 USD and WiFi enabled devices are not available in the general consumer market. BOxy, is Santa Clara University’s Ethical, Pragmatic, and Intelligent Computing (EPIC) Laboratory’s effort to produce the most cost-effective Bluetooth and WiFi enabled pulse oximeter using readily available and supported off-the-shelf components so that communities and health workers in rural, isolated, and impoverished regions of the world can easily purchase or build and certainly repair their own pulse oximeters rather than rely on costly or uncertain products or shipping costs.

**Keywords**—Blood Oxygen Meter (SpO<sub>2</sub>); Oximeter; Internet of Things (IoT); Infrared.

## I. INTRODUCTION

Pulse oximetry noninvasively measures a patient’s blood-oxygen level (SpO<sub>2</sub>) by analysing absorbed or reflected light from red oxygenated hemoglobin or from blue de-oxygenated hemoglobin in one’s pulmonary circulation [1]. From this optical information, the device calculates the person’s blood oxygen level using highly specific algorithms [2] to account for undesirable absorbance values as it passes through venous blood, or adipose, endothelial and epithelial tissue [1]. Pulse oximeters are commonly used in clinical settings, where health professionals monitor the level of oxygen in a patient’s blood, which is of paramount importance especially when the patient is undergoing artificial ventilation due to compromised lung capabilities or is under general anesthesia [3]. [4] sites that there are at least eight clinical applications of this technology, including detection of hypoxemia, assessing pulmonary gas exchange, and measuring blood pressure, among other uses. Pulse oximeters are also extensively useful in pediatrics [5] for monitoring pneumonia and other conditions, which has been proven to reduce child mortality rates [6]. Pulse oximetry has also been described as “one of the most important advances in respiratory monitoring” [7]. The availability of this technology provides a viable alternative to arterial blood samples, which are invasive [7]. Outside the medical clinic, pulse oximeters

are also used for measuring sleep apnea in adult sleep studies [8] and for detecting pneumonia in resident homes [9].

In third-world countries, there are efforts that push for the increased availability of pulse oximeters for monitoring critical health conditions [10]. Currently, it costs African hospitals 500 USD to replace their current oximeters, and 250 USD to repair small malfunctions, due to the outrageously high shipping costs for both the machine and its spare parts [11]. There is a great need for oximeters that are low-cost, easy to maintain and repair, portable, and convenient.

In Sections II and III some limitations and existing efforts for producing reliable cost-effective pulse oximeters are explored. Sections IV and V delineate the implementation of BOxy and some initial results respectively. And Section VI provides a road map of future additions and changes to BOxy which will transform the system from a prototype to a product.

## II. LIMITATIONS

There are currently some limitations to pulse oximeters applications, as they have not been proven to be effective for anemia, methemoglobinemia, vasoconstriction, motion artifact, hypotension, and carboxyhemoglobinemia [12]. However, there have been efforts to manage the discrepancies that arise due to motion artifacts, including those proposed by Masimo technologies, which allows for continuous monitoring in the face of poor tissue perfusion and patient movement [13]. Current oximeter standards hold that oximeters inaccuracies are inherent, and can only be reduced by a certain degree [14].

## III. RELATED WORK

There have been many recent efforts to improve current designs of the pulse oximeters that try to reduce its cost, increase its accuracy, increase its portability, etc. Attempts to create a smartphone based oximeter using a smartphone’s flashlight and camera to capture the reflectance and refraction of the light ray as it traverses through a finger have not been entirely successful because of various technological barriers, such as the smartphone camera’s inability to accurately detect infrared radiation [15]. Furthermore, such direct-detection methods using a smartphone can not extend to continuous monitoring even if their accuracy levels increase dramatically.

Researchers have also tried to create a micro-oximeter that could be placed on someone’s fingernail, made from flexible biomaterial [16]. Although this design could prove to be convenient for continuous measurement, no price range was specified. It seems reasonable to speculate that such a device would be priced highly due to the inherently high cost of flexible and compact biomaterials and biosensors being used.

Hewlett Packard corporation developed a smaller more portable family of pulse oximeters for clinical use in 1997



which were at the time revolutionary [17]. However, with the proliferation of cell phone technology in the past decades, much cheaper and more portable oximeters have been produced since. For instance, [18] is a low-cost oximeter that is linked to a smartphone display via a headphone jack connection. While this product is certainly a great step forwards in terms of usability and economics, a Bluetooth connection proves necessary because many current high-end smartphones lack a headphone jack altogether in favor of more sleek designs and features such as being waterproof. Furthermore, a bluetooth connection extends the range of operability by eliminating entangled wires.

Finally, versions of continuously monitoring oximeters do exist, but some require peculiar placements, such as on one’s eyeglasses [19], forehead [20], neck [21], or ear canal [22].

#### IV. DEVICE DEVELOPMENT

As the need for a cost-effective Bluetooth enabled oximeter is apparent, a prototype of such an Internet of Things (IoT) device using off-the-shelf components was undertaken by Santa Clara University’s Ethical, Pragmatic, and Intelligent Computing Laboratory.

##### A. Hardware

The prototype comprises of a single-board microcontroller (Arduino UNO REV3), a sensor chip (MAX30102 Pulse Oximeter Sensor Module [23]), and a Bluetooth module (HC-05 Bluetooth Serial Module [24]). In the first iteration, these components were connected via extensive jumper wiring, and with a breadboard simplifying the entire construction, ensuring stable connections and accurate feedback.

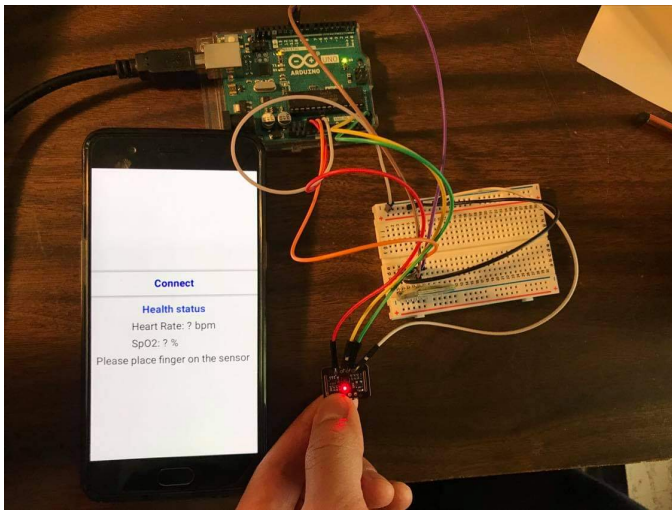

Figure 1. Blood oximeter prototype.

Figure 1 shows all the necessary components and their relevant connections and Figure 2 shows a simplified schematic of the system showing all the necessary connections. During operation, the system is completely independent and powered internally using a 9V battery. This could be replaced with a rechargeable battery source for environmental or economic reasons.

The sensor module is present on the exposed portion of the device surface, and uses an LED light to obtain blood

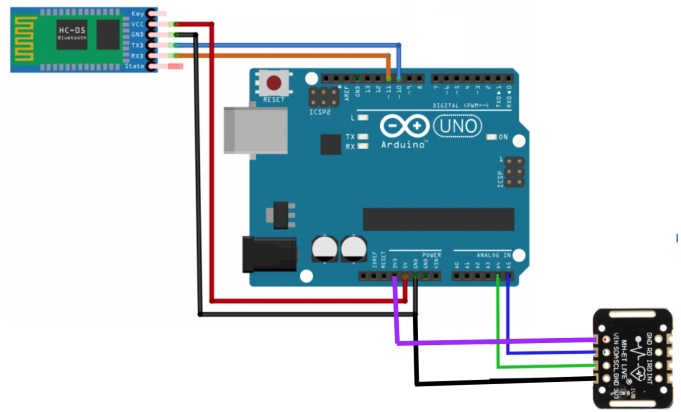

Figure 2. Blood oximeter Schematic.

Oxygen level readings through the skin noninvasively. The LED emits electromagnetic frequencies in the range of red and infrared light, which is the optimal range for hemoglobin SpO<sub>2</sub> analysis. Due to the constraints of human vision to light wavelength of approximately 720nm, the light emitted by the sensor appears red and looks like a laser, but is completely safe for human vision due to the sensor’s low power output.

1) *Design:* In accordance to frugal and minimalist design principles, the hardware has been simplified as much as possible. Not only will having fewer parts lower the costs associated with building and manufacturing the device, it will also increase the ease at which users could repair or replace the parts due to normal wear and tear per prolonged use.

The software for the device has also been designed with usability and simplicity in mind. The device software has been completely abstracted away from the user, and implements an advanced signal processing algorithm to generate data quickly and efficiently in the Arduino micro-controller, which has limited computational power.

Finally, a minimalist smartphone application has been implemented in a way to maximize ease of use while conserving resources, in terms of energy, storage, and computational power. Since the computational data filtering and analysis algorithm are housed solely on the microcontroller, the user’s smartphone needs only to display the information obtained via Bluetooth, freeing up computational resources to other applications, perhaps running in tandem. The user interface is completely intuitive and provides all the necessary instructions for all the tasks from connecting to the device, to optimally placing one’s finger on the sensor, to obtaining the blood oxygen content reading from the device.

2) *Materials:* The prototype features the following items, listed along with their prices:

- Arduino UNO REV3: 5.49, Banggood
- HC-05 Bluetooth Serial Module: 3.99, Banggood
- MAX30102 Pulse Oximeter Sensor Module: 2.10, Ali Express
- 8 Breadboard wires: 0.12 (1.5 cents each), Newegg

The total cost of the materials is 11.70 which at the time of this writing, is about a third of the cost for the cheapest Bluetooth enabled fingertip pulse oximeter available for purchase in the

United States. As will be discussed further in the Future Steps section below, the cost of this pulse oximeter can be reduced even further.

### B. Software

The program for the device includes calculations provided for the MAX 30102 chip in the "SparkFun MAX3010x Sensor Library". Bluetooth functionality and data communication was incorporated into this code, and the size of the variable arrays was reduced to decrease the static random access memory usage to alleviate memory shortcomings on the microcontroller. To enable Bluetooth communication between the Arduino and phone, an app was designed using the MIT App Inventor website.

## V. RESULTS

During the prototype testing phase, the oximeter was able to successfully show readings of blood oxygen level and heart rate. However, sometimes the user had to wait a moment before the oximeter would calibrate and display correct values. When the oximeter is unable to obtain data or if it detects an unrealistic SpO2 or heart rate measurement, such as if the user's finger is not on the sensor, it displays question marks and instructs the user to re-position their finger.

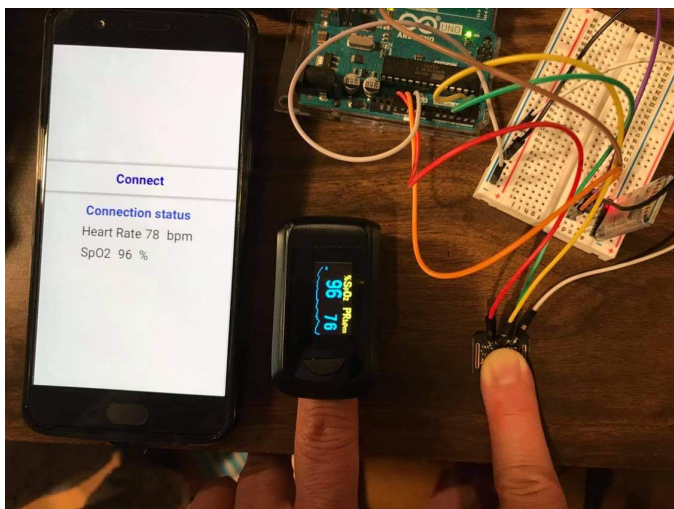

Figure 3. Blood oximeter results side by side

As depicted in Figure 3, the accuracy of the readings were tested against a commercially available fingertip Pulse Oximeter. Due to the extenuating circumstances brought about by the COVID-19 outbreak at the time of this writing, the device was not mass-tested, but the available data obtained from limited tests indicated a great degree of accuracy.

Accurate readings were however punctuated with intervals of higher variability in the blood oxygen and heart-rate readings displayed. There are several factors that could contribute to the periods of reading volatility; the most important of which being the difficulty of stabilizing a finger on the sensor for an extended period of time without some sort of support mechanism such as an alligator clip (common in medical instrumentation) or straps that immobilize the sensor across the skin (common in athletic and fitness monitoring equipment). Slight movements of the finger caused the chip to

measure inaccurate values, which resulted in the intervals of inconsistent readings observed on the smartphone application display until the finger comfortably rests on the sensor for long enough. Building a case to surround the components and thus allow the faster resting or immobilization of the finger tip on the sensor will alleviate this issue.

## VI. FUTURE STEPS

### A. Shrinking Circuitry Size

The Arduino Uno microcontroller used for the current working prototype, is considerably large and thus reduces the portability of the device. To reduce the size of the system, there are several possible alternatives that can be used. One option is the placement of the Arduino Uno board with smaller boards such as the Arduino Nano or Pro Mini. These two boards are primarily the same, with the only major difference being a substantial decrease in size. In addition, the Arduino Nano is available at a cheaper price (3.29 from Banggood). A second alternative is the combination of two of the components by utilizing an Arduino microcontroller with built-in Bluetooth capability. This would also effectively make the device smaller due to the elimination of the extra Bluetooth module used in the current prototype design. In addition, these microcontroller modules are available at prices cheaper than estimated costs for the separate microcontroller and Bluetooth modules.

### B. Addition of WiFi capability

Another way to increase the portability of the oximeter is to enable it to work completely separate from the phone. The addition of a WiFi module would enable the device to connect directly to a web service and store its readings. These readings could then be pushed to a web or mobile GUI for the user's viewing or aggregated and graphed for trend building and analytics as part of the medical record of an athlete or patient for instance. In case of no WiFi connectivity, the device could take advantage of the microcontroller's internal memory to store its readings and to push them to the server once WiFi signal becomes available again.

At the time of this writing, arduino compatible development boards with both Bluetooth and WiFi radio modules onboard in the form of Dual Core CPU with Low Power Consumption MCU ESP-32S are available for 2.08 USD which provides more functionality in a smaller form factor and at cheaper cost. The use of such a board would effectively reduce the prototype cost to less than 9 USD while increasing its functionality to include WiFi capability as aforementioned.

### C. Custom PCB

In making the device more stable and practical for use, the use of a custom Printed Circuit Board (PCB) will be required. This will not only eliminate the need for wires and the breadboard, but also provide stability in electrical connections between the components. PCBs can also enable a decrease in size of the device and make installation more effective and convenient.

Furthermore, the design and fabrication of a custom PCB with all electronic components onboard would reduce the cost drastically during mass production as it would be a single purpose board and not need the general purpose design and components of the commercially available microcontroller development boards aforeused and aforementioned.

#### D. 3D Printed Casing

The addition of a casing would provide more structural support for the device and contribute to the visual aesthetic. A 3D printed casing would also protect the internal components from collecting dust or otherwise natural weathering by the external environment. A 3D printed casing was not produced for the proof of concept prototype but is under design for the smaller sized prototype which uses an ESP32 development board.

#### E. UI Design

Improving the app design and the user interface will benefit the userfriendliness of the device. Furthermore, providing a graph showing the trend based on multiple data points over time will be more useful and beneficial to a person that requires or prefers periodic monitoring of their heart rate and blood-oxygen levels. And lastly, it will be more practical to include instructions for the most effective usage of the device in order to provide a guide as well as troubleshooting steps to the users.

#### F. User Testing

To make sure that the device measures heart rate and SPO2 levels properly across a variation of scenarios, sufficient user testing is necessary. In testing BOxy's prototype, due to limitations outlined by COVID-19 restrictions, this was not possible. In the development of future designs and additions delineated above, extensive user testing will be carried out more robustly in order to verify the reliability and viability of the device.

### VII. CONCLUSION

BOxy is a cost effective, portable, convenient, and easy to repair pulse oximeter built from readily obtainable components. These features enable the development, deployment, and maintenance of reliable SPO2 sensing in low income, remote, or technologically isolated communities. There is still great room for improvement, as delineated in the future steps section above, but the initial results have proven the possibility of building such an oximeter. With the progress shown thus far and the remaining improvements delineated above, BOxy has the capability of playing a role in preserving the lives of patients worldwide as the need for an oximeter with BOxy's attributes to be available to monitor the pulmonary health of pediatric and geriatric patients in remote rural areas and impoverished nations is very pressing.

### ACKNOWLEDGMENT

Many thanks are due to Santa Clara University's department of Bioengineering as well as the Frugal Innovation Hub for their continued support of the project.

### REFERENCES

- [1] M. Yelderian and W. New, "Evaluation of pulse oximetry," *Anesthesiology: The Journal of the American Society of Anesthesiologists*, vol. 59, no. 4, 1983, pp. 349–351.
- [2] T. Rusch, R. Sankar, and J. Scharf, "Signal processing methods for pulse oximetry," *Computers in biology and medicine*, vol. 26, no. 2, 1996, pp. 143–159.
- [3] K. K. Tremper and S. J. Barker, "Pulse oximetry," pp. 98–108, 1989.
- [4] A. Jubran, "Pulse oximetry," *Intensive care medicine*, vol. 30, no. 11, 2004, pp. 2017–2020.

- [5] J. W. Salyer, "Neonatal and pediatric pulse oximetry," *Respiratory care*, vol. 48, no. 4, 2003, pp. 386–398.
- [6] T. Duke, R. Subhi, D. Peel, and B. Frey, "Pulse oximetry: technology to reduce child mortality in developing countries," *Annals of tropical paediatrics*, vol. 29, no. 3, 2009, pp. 165–175.
- [7] A. Jubran, "Pulse oximetry," *Critical care*, vol. 3, no. 2, 1999, p. R11.
- [8] N. Netzer, A. H. Eliasson, C. Netzer, and D. A. Kristo, "Overnight pulse oximetry for sleep-disordered breathing in adults: a review," *Chest*, vol. 120, no. 2, 2001, pp. 625–633.
- [9] K. S. Kaye, M. Stalam, W. E. Shershen, and D. Kaye, "Utility of pulse oximetry in diagnosing pneumonia in nursing home residents," *The American journal of the medical sciences*, vol. 324, no. 5, 2002, pp. 237–242.
- [10] C. King et al., "Opportunities and barriers in paediatric pulse oximetry for pneumonia in low-resource clinical settings: a qualitative evaluation from malawi and bangladesh," *BMJ open*, vol. 8, no. 1, 2018, p. e019177.
- [11] M. W. Weber and E. K. Mulholland, "Pulse oximetry in developing countries," *The Lancet*, vol. 351, no. 9115, 1998, p. 1589.
- [12] J. E. Sinex, "Pulse oximetry: principles and limitations," *The American journal of emergency medicine*, vol. 17, no. 1, 1999, pp. 59–66.
- [13] J. M. Goldman, M. T. Petterson, R. J. Kopotic, and S. J. Barker, "Masimo signal extraction pulse oximetry," *Journal of clinical monitoring and computing*, vol. 16, no. 7, 2000, pp. 475–483.
- [14] M. Nitzan, A. Romem, and R. Koppel, "Pulse oximetry: fundamentals and technology update," *Medical Devices (Auckland, NZ)*, vol. 7, 2014, p. 231.
- [15] S. Tomlinson, S. Behrmann, J. Cranford, M. Louie, and A. Hashikawa, "Accuracy of smartphone-based pulse oximetry compared with hospital-grade pulse oximetry in healthy children," *Telemedicine and e-Health*, vol. 24, no. 7, 2018, pp. 527–535.
- [16] J. Kim et al., "Miniaturized battery-free wireless systems for wearable pulse oximetry," *Advanced functional materials*, vol. 27, no. 1, 2017, p. 1604373.
- [17] S. Kästle, F. Noller, S. Falk, A. Bukta, E. Mayer, and D. Müller, "A new family of sensors for pulse oximetry," *HEWLETT PACKARD JOURNAL*, vol. 48, 1997, pp. 39–47.
- [18] C. L. Petersen, H. Gan, M. J. MacInnis, G. A. Dumont, and J. M. Ansermino, "Ultra-low-cost clinical pulse oximetry," in *2013 35th Annual International Conference of the IEEE Engineering in Medicine and Biology Society (EMBC)*. IEEE, 2013, pp. 2874–2877.
- [19] F. Braun et al., "Evaluation of a novel ear pulse oximeter: Towards automated oxygen titration in eyeglass frames," *Sensors*, vol. 20, no. 11, 2020, p. 3301.
- [20] G. Comtois, Y. Mendelson, and P. Ramuka, "A comparative evaluation of adaptive noise cancellation algorithms for minimizing motion artifacts in a forehead-mounted wearable pulse oximeter," in *2007 29th Annual International Conference of the IEEE Engineering in Medicine and Biology Society*. IEEE, 2007, pp. 1528–1531.
- [21] M. Peng, S. A. Imtiaz, and E. Rodriguez-Villegas, "Pulse oximetry in the neck—a proof of concept," in *2017 39th Annual International Conference of the IEEE Engineering in Medicine and Biology Society (EMBC)*. IEEE, 2017, pp. 877–880.
- [22] J. P. Buschmann and J. Huang, "Pulse oximetry in the external auditory canal—a new method of mobile vital monitoring," *IEEE Sensors Journal*, vol. 12, no. 3, 2011, pp. 671–676.
- [23] "Arduino heart rate monitor using max30102 and pulse oximetry," 2019. [Online]. Available: <https://makersportal.com/blog/2019/6/24/arduino-heart-rate-monitor-using-max30102-and-pulse-oximetry>
- [24] "Hc-05 datasheet — bluetooth transceiver module," 2019. [Online]. Available: <https://maker.pro/custom/tutorial/hc-05-bluetooth-transceiver-module-datasheet-highlights>

# GluMo: A Noninvasive Blood Glucose Monitor

Ben Tan, Peter Ferguson, Teddy Nguyen, Hanna Albright, Navid Shaghghi, and Zhiwen Zhang,

Ethical, Pragmatic, and Intelligent Computing (EPIC) Laboratory

Santa Clara University, Santa Clara, California, USA

{jtan1, pferguson, tpnguyen1, halbright, nshaghghi, zzhang}@scu.edu

**Abstract**—Diabetics are used to pricking their fingertips in order to check their glucose level. In an effort to sunset that practice, Santa Clara University’s Ethical, Pragmatic, and Intelligent Computing (EPIC) Laboratory has envisioned, designed, and prototyped a portable noninvasive glucose monitoring medical instrument which we have dubbed GluMo. In place of a drop of blood GluMo uses Infrared (IR) light emitters and receivers as part of a small form factor Internet of Things (IoT) medical instrument which calculates the amount of the IR wave’s interaction with glucose molecules within the blood stream. The information is then transmitted to a database for tracking, history building, and data visualization for the patient (and potentially the patient’s doctor if authorized). Since current single droplet blood glucose meters are attainable as cheap as 10 USD, in order to keep GluMo’s cost under 100 USD without diminishing the accuracy of the reading outside of an acceptable bounds, Near Infrared (NIR/IR-A DIN) emitters at the 1300 nanometer (nm) wavelength and corresponding receivers were chosen for the prototype. The choice of 1300nm NIR/IR-A comes from the fact that 60% of human blood is water (H<sub>2</sub>O) and 1300nm NIR/IR-A has the largest positive difference between its absorbance in glucose and its absorbance in water among the other wavelengths of IR in the NIR/IR-A range.

**Keywords**—Blood Glucose Monitor; Infrared (IR); Internet of Things (IoT); Medical Instrumentation; Non-invasive.

## I. INTRODUCTION

Diabetes is a chronic disease caused by an inherited and/or acquired deficiency in the production of insulin by the pancreas, or by the ineffectiveness of the insulin produced. Such a deficiency results in increased concentrations of glucose in the blood, which in turn damage many of the body’s systems such as the vision and digestive systems, as well as organs such as the heart, blood vessels, nerves, kidneys, and even skin [1]. Diabetes is thus the seventh leading cause of death in the United States as it is a factor in causing serious health complications including heart disease, blindness, kidney failure, and lower-extremity amputations [2]. According to the International Diabetes Federation, in 2017, over 425 million adults suffered from diabetes. This number is estimated to increase to over 629 million within a generation (2045) [3].

With regular glucose monitoring, patients can maintain normal glucose levels and thus can prevent or delay the aforementioned diabetes-related complications. The current method for monitoring blood glucose levels requires a drop of blood to be obtained by pricking a finger tip with a retractable needle. However, this method is invasive, painful, and sometimes messy for the users. It can also cause infections over time with regular use [4] due to the usage of un-sterilized needles, repeated usage of needles which were designed for single usage, or the sharing of needles/prickers between patients.

The replacement of this painful, messy, and unsafe method

of blood glucose monitoring is thus under much research and development as is explored in the Related Work Section below. Sections II and III will cover the consumer needs and existing efforts respectively. Section IV will delineate GluMo’s design and implementation and Section V will report on GluMo’s preliminary results. Finally, Section VI previews the many redesigns, improvements, and additions currently under research and development at Santa Clara University’s Ethical, Pragmatic, and Intelligent Computing (EPIC) research lab which aims to create GluMo’s Minimal Viable Product (MVP).

## II. CONSUMER NEEDS

With a significant and rapid increase in the prevalence of type II diabetes in the world’s population, the ability to continuously detect the amount of glucose in the blood is particularly relevant. Diabetics must be able to quickly and accurately test their blood glucose level in order to appropriately regulate their blood sugar level in response. Current single drop blood glucose meters allow the patient to self-monitor their blood glucose levels regularly throughout the day in an accurate way. However, because they must directly analyze blood to determine its concentration of glucose, patients are forced to prick their fingers for each reading, making monitoring blood sugar an inherently noncontinuous, invasive, painful, and potentially unhygienic process. In addition, the single-use test-strips required by these meters represent an ongoing expense for the patients, which is especially costly for those requiring multiple tests throughout the day. The quality of the test-strips does also effect the accuracy of the blood glucose level readings especially if damaged or expired.

Therefore, although currently available meters allow patients to accurately meter their blood glucose concentration, they do not make the experience pleasant nor completely safe. Pricking the skin for the extraction of blood does pose a potential health hazard. The finger pricker’s needle may accumulate microbes and/or viruses and thus inject the patient with them inadvertently. Also, patients report that to save money they often reuse their prickers’ needles even up to several days or a week. The pricking needle is also not considered safe for children and can be very harmful if used improperly. The needle, just for instance, is capable of damaging the eye if accidentally or maliciously used in that area.

Therefore, what diabetic patients need, is a continuous, painless, hygienic, and safe alternative which also does not incur an indefinite cost of test-strips and needles.

## III. RELATED WORK

As reported by researchers McNicoles and Coté [5] back in the year 2000 “over 100 small companies and universities were

working to develop noninvasive or minimally invasive glucose sensing technologies". Yet, a 2019 search of online retailers such as Amazon, Ebay, and Alibaba results in a scant number of extremely expensive devices such as the Glucose Wizard [6] at a price tag of nearly 1150 USD or OMELOON B-2 [7] at a price tag of nearly 400 USD and an overarching number of reviews which report the device's inaccuracy in measuring blood sugar levels yet doing well as a blood pressure meter.

Glucose detection using IR spectroscopy is not a new discovery [8]. In fact, among the aforementioned 100 ventures of the two past decades, McNicoles and Coté [5] report that the optical methods for measuring glucose levels had the biggest share. More specifically, they indicate that the NIR/IR-A DIN (DIN standing for the Deutsches Institut für Normung or the German Institute for Standardization) region of the infrared optical spectrum has been the primary region of focus in academia and industry as it has the least IR radiation absorbance in water in comparison to the other IR spectrum regions such as the short-wavelength IR (SWIR/IR-B DIN) and mid-wavelength IR (MWIR/IR-C DIN) regions. However, much of the early work in the NIR/IR-A have been of purely proof-of-concept nature and thus have used large and relatively expensive bench-top machines [9] such as the Fourier Transform Infrared (FTIR) [10] instruments and grating spectrometer [11] instruments.

Many researchers have also suggested that the thickness of the human skin can cause the scattering of the IR signal. For instance in 1982, researchers suggested measuring the glucose level of the aqueous humor of the eye as a measure of the blood glucose concentration in the blood [12]. They indicated that this would lead to the development of noninvasive blood glucose meters for public usage but as of 2019 no such publicly available devices have been found in the market by the authors.

In a different approach, GlucoTrack is a noninvasive non-IR solution through combining ultrasonic, electromagnetic, and thermal technologies for the measurement of glucose in the blood through the ear lobe [13]. However, because the device is so close to the patient's ear, and the fact that numerous studies such as [14], [15], and [16] exist which link ultrasonics to human ear damage and thus hearing degradation, the device has the potential of damaging the eardrum due to its continued bombardment with ultrasonic waves. More time and usage data are necessary to ascertain the true health effects of the device on longtime users.

#### IV. DESIGN AND IMPLEMENTATION

GluMo is a multi-phased research project. Phase 1, which will be expand on in this section, was the proof of concept and prototyping phase. Phase 2 is the MVP phase in which the size of the instrument is reduced to pocket-sized and potential IR frequency changes outside of NIR/IR-A are explored for further increasing accuracy. Much work on this phase has also been completed or is near completion. However, a thorough cost-benefit analysis will contrast the accuracy gain of the system against the higher cost of the non-NIR/IR-A LEDs which will need to be used instead. And phase 3 consists of a robust human subject field testing of GluMo beyond the laboratory setting which included carefully crafted test tubes containing precise glucose solutions. The inherent uncertainty and messyness of the real world will thus help fine-tune GluMo's design in preparation for the next phase. Lastly,

phase 4 is the further reduction of the size to a system on a chip for the incorporation of the bio-medical instrument within common wearables such as smart watches.

##### A. Electronics

The electronics of GluMo consists of 2 closed circuits. One for an IR emitter at the 1300nm wavelength, and another for an IR receiver - a photodiode designed to be able to detect IR signals around 1300nm. The choice of 1300nm NIR/IR-A is due to two separate requirements of the system: low cost, and accuracy. Since current single droplet blood glucose monitors are purchasable from online retailers as cheap as 10 USD, in order to satisfy the market imposed requirement of keeping GluMo's prototype's cost under 100 USD, the emitter chosen for the prototype needed to be a Near Infrared (NIR/IR-A DIN) LED as LEDs in this range are attainable off the shelf at under 20 USD.

However, another requirement for the GluMo prototype is to maintain a glucose measurement accuracy within an acceptable bounds. Due to the fact that 60% of human blood is water (H<sub>2</sub>O) and that among the other wavelengths of IR in the NIR/IR-A range the 1300nm NIR/IR-A has the largest positive difference between its absorbance in glucose and in water [17], the 1300nm NIR/IR-A satisfies the requirement for maintaining a glucose measurement accuracy within the acceptable bounds.

##### B. Software

Arduino C code is used to control the instrument, to analyze the data from the IR receiver, and to transmit the results to a computer for analysis. Using built-in Arduino functions, 1000 voltage-readings from the photodiode are averaged and after observing 10 of these values, the most frequently occurring value is recorded. Furthermore, a delay of 1 second between readings is established and the voltage values from the IR receiver are converted to percentage of transmittance and then inverted into absorbance. These absorbance values are then converted to blood glucose values given an experimentally derived equation for a standard curve of glucose concentration vs. absorbance as follows:

$$Glucose = \frac{Absorbance - 0.2671}{0.4665} \quad (1)$$

However, due to the indeterminate nature of reality, the aforementioned 1 second spaced readings are not constant and fluctuate slightly around the actual value. This can be remedied by increasing the number of readings to 10,000 values instead of 1000 and averaging the results. It therefore follows that obtaining even more readings and averaging their value should result in a more accurate value. However, the patience of a user must be here considered. How long would a diabetic patient be willing to wait with his or her finger inside of the instrument in order to get an accurate reading? Therefore, a band-pass software filter was created to exclude outlying values in order to increase the accuracy of the average value even on fewer reading samples. The final decision on the number of readings necessary as well as the exact values to set the band-pass filter to, are yet to be determined as further human subject testing is necessary to fine tune these values. Though we do foresee this fine-tuning to be also individual based and perhaps even part of an automated initial calibration step when a patient utilizes the device for the first time.

### C. 3D printed Casing

The circuitry was placed in a 3D-Printed box, made from PLA, designed to minimize interference from outside light in order to focus the infrared light through the patient’s finger’s tissue and onto the photo-diode receiver. The box consists of a lid and a main body, as seen in Figure 1, with two openings: one for a USB cable that powers the system and transmits the results to a connected computer, and another for the patient’s finger. The main body and the top have screw holes at each corner so that the box can be sealed securely from any interfering light.

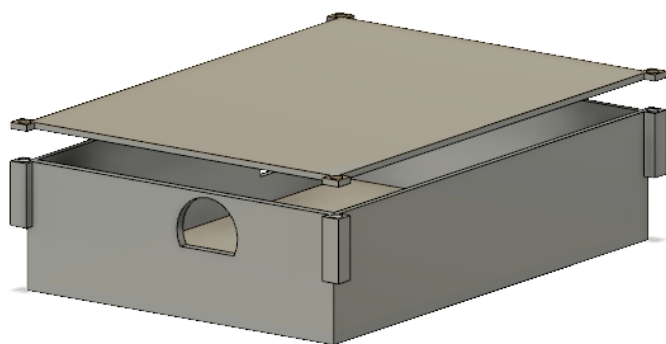

Figure 1. 3D-Printed GluMo Housing

### V. RESULTS

To calibrate, test, and validate GluMo a series of test tubes with varying levels of glucose concentration were built and utilized repeatedly to test accuracy in face of both variance and strain of continued usage. In order to best resemble the human skin, the test tubes were built from powder-less and lubricant-free condoms. The error in measurements were under 10% With a high average level of accuracy at 99.2%. However, since this will be a medical device which millions will rely upon for regulating their blood glucose levels, we are aiming for 100% accuracy.

Human subject testing was also conducted on team members and verified against traditional single blood droplet glucose meters with the same levels of error and accuracy when multiple results are averaged. As an example, the table in Figure 2 shows 5 consecutive measurements for a single subject. The average blood glucose concentration measurement taken by the noninvasive meter was 113.65mg/dL. This value represents a 0.6% error compared to the value given by the commercial meter, suggesting that the meter is highly accurate. However, as the calculated p-values comparing each measurement to this average value indicate, the precision of each individual measurements was not as ideal. The p-values indicate the certainty with which each measurement can be assumed to be equal to the average value, with a maximum value of one. There is 90% confidence in the measurement for each of the five trials, with two trials indicating that their respective values are definitively different from the average measurement with p-values of almost zero.

The high accuracy of the average glucose measurement despite this lack of precision was caused by a fairly even distribution of individual measurements above and below the average value. Many more human subject test are necessary

	Trial 1	Trial 2	Trial 3	Trial 4	Trial 5
[Blood glucose], (mg/dL)	113.42	107.92	115.31	119.10	112.48
p-value <sup>1</sup>	0.902	0.002	0.362	0.003	0.523

<sup>1</sup> p-values calculated using two-tailed z test comparing each blood glucose concentration measurement to the average measurement of 113.65mg/dL

Figure 2. Blood glucose concentration measurements and p-values from glucose meter testing.

in order to validate the accuracy levels. However, due to the COVID19 Pandemic at the time of this writing the human subject testing was very limited and insufficient to validate that the high level of accuracy will be maintained across a wide verity of patient skin types. A more extensive human subject testing will be conducted once the second phase prototype is completed as delineated further below.

### VI. WORK IN PROGRESS

The first prototype of GluMo has been produced as a proof of concept. The second pocket-sized GluMo prototype is under development as an MVP for a marketable alternative to today’s blood droplet glucose meters.

#### A. Spectroscopy

In order to find the optimal IR wavelength to absorb glucose in water, the full range of IR is being explored. As seen in Figure 3, at around 1650nm, the absorbance of IR in water is zero [18]. Hence, this region provides a unique opportunity for testing the accuracy of measuring glucose in blood. Thus, the entire absorbance recorded by the system should only be the absorbance of IR in glucose without needing to subtract the absorbance of water. However, this will cause the instrument to be more expensive than 100 initially until economies of scale lower the product’s cost of production.

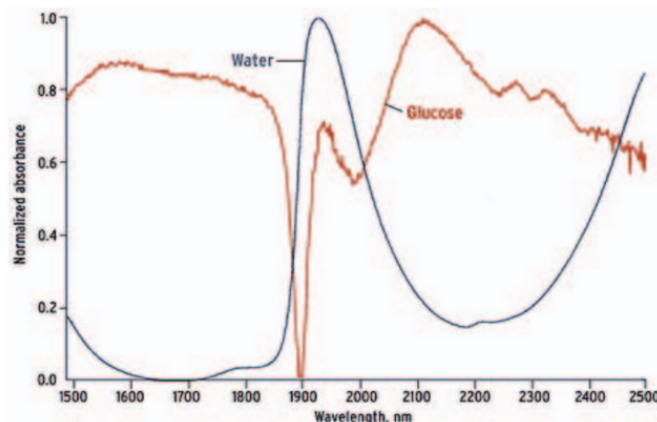

Figure 3. Water and Glucose Solution Absorbance spectra 1500nm – 2500nm. [18]

However, a complete IR spectroscopy of glucose vs water will be conducted in order verify this finding or to better select the IR range which will have the highest absorbance in glucose, yet lowest absorbance in water.

#### B. Pocket sized MVP with 3D-Printed casing

The current GluMo prototype, even though light weight and robust, is still too big for every day usage. Granted that

competitor devices such as the Glucose Wizard or OMLN B-2 are still bigger than GluMo in size, GluMo's circuitry can still be shrunk down substantially with low cost off-the-shelf available components alone. The packaging of the MVP in a custom 3D-Printed casing also allows for a lot of flexibility in the design of both the internal and overall looks and feel of the instrument. The intricate design details of the Pocket sized GluMo MVP and its results, will be the subject of the authors' next paper; but it is noteworthy that the completion of the MVP enables consumer testing of the instrument.

### C. Rechargeable Battery and apparatus for USB charging

The GluMo MVP will be a portable pocket-sized device. Hence, it will need to operate even when not plugged in to a power source. Therefore, the MVP will include a small, internal, and rechargeable battery and a charging board. The USB port which serves as a data port in the Phase 1 prototype will then be re-purposed for charging the battery. There will also be a small OLED to display the battery status and the current blood glucose level.

### D. Wireless communication

The GluMo prototype in phase 1 is designed to utilize serial communication using a USB cable. However, a point to point communication system consisting of nrf24 transceivers was tested as a proof of concept. GluMo's pocket-size MVP in phase 2 will have WiFi capabilities in order to allow the instrument's direct connection to the home or facility WiFi router for its independent access to an online database. This will allow the centralization of the patient's glucose reading history for easier access by the patient as well as the patient's care taker and/or doctor.

### E. Web application

Our current prototype's data visualization is merely numeric based, with minimal explanatory details, and geared towards researchers and experts in the domain. In order to enable the mass usage of the instrument by users, a web based Graphical User Interface (GUI) is being developed. The interface will include numeric results of the readings as well as interactive graphs to help patients, their care takers, and physicians to better track their glucose levels across time periods. Furthermore, user's will be able to view their glucose readings over a specified period of time, such as the past day, week, or month. The application will also feature an alert capability which can automatically send messages to the patient's authorized care taker(s) or health provider(s) in case of a sustained abnormal glucose reading level, provided such alerts are set up.

## VII. CONCLUSION AND FUTURE STEPS

An alternative to the classical single droplet blood glucose monitors which are prevalent today is a painless, hygienic, noninvasive glucose monitoring system utilizing infrared light waves; and it does not have to cost 1150 USD. There is at least 3 decades worth of evidence that researchers in companies and universities have been working on noninvasive blood glucose meters with most of them utilizing optics of some sort. The physics and chemistry of the absorbance of IR in glucose is thus not a new discovery, yet no reliable, portable, low cost, noninvasive blood glucose meter has made its way to the

market. GluMo is an attempt at that and as the preliminary prototype results indicate it is a promising attempt. Once GluMo's pocket-sized MVP is completed and the limitations imposed by the COVID-19 pandemic are alleviated, a period of rigorous human subject field testing will finally present GluMo as the light at the end of the more than 3 decade long effort to enhance the lives of those struggling with diabetes by lessening their pain by a few needle pricks a day.

## ACKNOWLEDGMENT

Many thanks to Santa Clara University's maker lab for providing 3D-Printing services for the project as well as the Frugal Innovation Hub and the Department of Bio Engineering for their continued support of the project.

## REFERENCES

- [1] Healthier Talk, "6 ways high blood sugar silently damages your body," 2017. [Online]. Available: <https://healthiertalk.com/6-ways-high-blood-sugar-silently-damages>
- [2] Center for Disease Control and Prevention, "Diabetes." [Online]. Available: <https://www.cdc.gov/media/presskits/aahd/diabetes.pdf>
- [3] International Diabetes Foundation, "Diabetes statistics," 2017. [Online]. Available: <https://www.idf.org/our-activities/education/idf-school-of-diabetes.html>
- [4] S. Clarke and J. Foster, "A history of blood glucose meters and their role in self-monitoring of diabetes mellitus," *British journal of biomedical science*, vol. 69, no. 2, 2012, pp. 83–93.
- [5] R. J. McNichols and G. L. Coté, "Optical glucose sensing in biological fluids: an overview," *Journal of biomedical optics*, vol. 5, no. 1, 2000, pp. 5–17.
- [6] Glucose Wizard, "Glucose wizard." [Online]. Available: <http://www.glucosewizard.com/index.html>
- [7] OMLN B-2, "Omelon b-2." [Online]. Available: <https://diabetestalk.net/blood-sugar/omelon-b2-non-invasive-glucometer>
- [8] G. L. Coté, "Noninvasive optical glucose sensing—an overview," *Journal of Clinical Engineering*, vol. 22, no. 4, 1997, p. 253.
- [9] —, "Noninvasive and minimally-invasive optical monitoring technologies," *The Journal of nutrition*, vol. 131, no. 5, 2001, pp. 1596S–1604S.
- [10] NIST, "Fourier transform infrared spectroscopy," 2016. [Online]. Available: <https://www.nist.gov/laboratories/tools-instruments/fourier-transform-infrared-spectroscopy>
- [11] B. E. Sauer, "The grating spectrometer," 2007, imperial College of London Laboratory Notes.
- [12] B. Rabinovitch, W. March, and R. L. Adams, "Noninvasive glucose monitoring of the aqueous humor of the eye: Part i. measurement of very small optical rotations," *Diabetes Care*, vol. 5, no. 3, 1982, pp. 254–258.
- [13] Integrity Applications, "Glucotrack." [Online]. Available: <http://www.glucotrack.com/about-glucotrack/>
- [14] B. Smagowska and M. Pawlaczyk-Łuszczynska, "Effects of ultrasonic noise on the human body—a bibliographic review," *International Journal of Occupational Safety and Ergonomics*, vol. 19, no. 2, 2013, pp. 195–202.
- [15] W. Acton, "The effects of industrial airborne ultrasound on humans," *Ultrasonics*, vol. 12, no. 3, 1974, pp. 124–128.
- [16] H. O. Parrack, "Effect of air-borne ultrasound on humans," *International Audiology*, vol. 5, no. 3, 1966, pp. 294–308.
- [17] H. Yoshinari, H. Ishizawa, M. Fukuda, S. Tokutake, S. Koyama, and Y. Miyauchi, "Non-invasive self monitoring of blood glucose system using near-infrared spectroscopy," in 2012 Proceedings of SICE Annual Conference (SICE). IEEE, 2012, pp. 1852–1854.
- [18] R. Hotmartua, P. W. Pangestu, H. Zakaria, and Y. S. Irawan, "Non-invasive blood glucose detection using near infrared sensor," in 2015 International Conference on Electrical Engineering and Informatics (ICEEI). IEEE, 2015, pp. 687–692.

# A Systematic Review of Ambient Display Modalities, Physical Forms and Interactivity

Ben Shelton

The University of Newcastle, Australia  
 School of Electrical Engineering and Computing  
 Newcastle, Australia  
 e-mail: ben.shelton@newcastle.edu.au

Keith Nesibtt

The University of Newcastle, Australia  
 School of Electrical Engineering and Computing  
 Newcastle, Australia  
 e-mail: keith.nesibtt@newcastle.edu.au

**Abstract**—A systematic review of 459 Ambient Displays, reported in 410 publications between 1996 and 2016 was used as the basis for an analysis of the high-level design features associated with the technology. An analysis of these displays considers three main aspects: the modalities used to display information, the physical form of the displays and the level of implemented interaction. The paper provides a longitudinal overview of the various forms of Ambient Displays over a twenty-year period. This allows for the provision of a comprehensive timeline of past work in the field of Ambient Display and establishes a sound basis for further reviews or studies related to this technology.

**Keywords**—Ambient Display; Peripheral Display; Systematic Review, Evaluation; Modality.

## I. INTRODUCTION

Ambient Displays or Ambient Information Systems are designed as everyday, peripheral information sources that visualise useful data in a way that can be attended to when possible [1]. They are designed to display abstracted, non-critical information on the periphery of a user's attention [2] [3]. They should be non-obtrusive and try not to overload the senses [4] [5] while also considering the aesthetic appeal of the display and the need to be seamlessly embedded within an everyday environment [2] [6] [7].

The field of Ambient Display was motivated by Calm Technology [8], a desire for less intrusive displays in a noisy world of dynamic and ubiquitous information. The technology, under different names, has been studied since about 1996 and is most commonly referred to as Ambient Displays, Ambient Information Systems, Peripheral or Pervasive Displays [9]-[12].

There have been several narrative reviews of the technology in the past [1] [7] [13]-[30]. However, these narrative reviews do not attempt to cover the majority of historical examples of Ambient Display. This paper is designed to address this gap and categorise key design features based on the analysis of results from a systematic review [31] that identified 459 Ambient Displays published in 410 studies between 1996 and 2016. This historical analysis supports a fuller description of the common attributes of Ambient Display in a field comprised of disparate systems that has evolved over time. Providing a

comprehensive timeline of historical studies into the field of Ambient Display offers a sound basis for detailed meta-analysis of the technology and acts as an introduction to the field's progression across the design, development and evaluation of Ambient Display.

While some other studies have also taken a systematic approach [31]-[33], these works focus on restricted portions of the domain and thus describe a more limited set of the overall number of Ambient Displays. This study takes a more expansive approach, assuming that further insights may be gained by a systematic categorization of a large, longitudinal sample of this display technology.

The systematic review identifies three broad design categories of Ambient Displays, the modalities used to display information, the physical form of the display itself and the level of interaction implemented. It serves to highlight some key differences in the types of Ambient Displays and suggests gaps in the field.

This analysis begins next in Section 2 which discusses previous naming conventions and definitions for the technology, which leads to the systematic review methodology that is documented in Section 3. Sections 4, 5 and 6 discuss each of the major design attributes of the technology discovered through the review process including; modality (see Section 4), physicality (see Section 5) and interaction (see Section 6). This leads to discussion of conclusions and future work, which are presented in Section 7.

## II. NAMING CONVENTIONS AND DEFINITIONS

The definition of Ambient Display technology is difficult as there are no consistently accepted terms used to describe these systems in the existing literature [1]. This includes the key features of the technology, which can be described in divergent ways while still being interpreted as aligning to the ideals of Calm Technology [8]. So, just what is an Ambient Display, and how has the technology developed over time?

Common overarching names for this type of display technology include Ambient Displays, Ambient Information Systems, Peripheral or Pervasive Displays [9]-[12]. There are some reoccurring themes within the previously suggested definitions of the technology. These include the display of potentially useful [10] [36] information [1]-[6] [11] [19] [34]



[36]-[41] in one’s periphery [4] [34] [56] [57] [61] through aesthetically designed systems [2] [6] [7] [10] that do not impose on the user or become intrusive [4] [5] [19] [34] [39] [43].

These divergent attributes suggest the need for a more structured review process, to understand how the domain has developed over time and to highlight general categories of these technologies. Therefore, this review aimed to document a high volume of previous displays and quantify them into broad design categories that would inform how the key design features of such displays have developed over time.

### III. METHOD

A systematic review was designed to analyze a large body of published work related to Ambient Displays. This was intended to cover a twenty-year period beginning with the suggestion of Calm Technology in 1996, through to the end of 2016.

The disparate nomenclature of the technology had to be addressed early when selecting terms used to query the academic databases. A pragmatic approach was taken in selecting Ambient Display, Ambient Information System, and Peripheral Display as key terms for search. This decision was based on the common use of these naming schemes. Since this search identified over fifteen thousand articles, it was decided not to include further terms.

These terms were queried in four separate academic databases; ACM Digital Library, IEEE Xplore, Scopus and Web of Science. The attributes of the search query used in each database are shown in Table 1.

Searching across these three databases resulted in over fifteen-thousand documents (n=15,693), which required further assessment for determining their relevance to the study. Only papers that documented a specific Ambient Display design, implementation or discussed theoretical concepts relating to the technology were included.

As a next check, all publications were assessed to determine if the system described was consistent with two typical definitions of Ambient Display (see Table 2). This process acted as a further pre-screening of the literature that did not align to the intentions of this research.

TABLE I. ATTRIBUTES OF THE QUERIES USED TO SEARCH FOR RELEVANT LITERATURE

<b>Databases</b>	ACM Digital Library, IEEE Xplore, Scopus and Web of Science
<b>Years</b>	1996 – 2016
<b>Document Types</b>	Journal Articles, Conference Papers, Works in progress
<b>Language</b>	English
<b>Keywords</b>	Ambient Display, Ambient Information System, Peripheral Display

TABLE II. THE TWO DEFINITIONS USED IN THE INITIAL ASSESSMENT OF LITERATURE

<b>Definition 1</b>	“Ambient displays are abstract and aesthetic peripheral displays portraying non-critical information on the periphery of a user’s attention.” [2]
<b>Definition 2</b>	“Ambient Information Systems are designed as everyday, peripheral information sources that visualise useful data in a way that can be attended to when possible.” [1]

Publications that were found to conform to either of these definitions were considered further to determine if the described technology conformed to the original ideals of Calm Technology [8]. Advertising displays and displays relating directly to digital signage were excluded. Finally, publications describing systems with high levels of user-interaction, such as computing games or interactive information systems were excluded.

This screening process resulted in 410 unique documents that were judged as being most relevant to this study. Most of the literature was found to relate to the development and evaluation of Ambient Display (n=254) or the development of Ambient Display (n=115). The remaining literature was found to relate to the evaluation of Ambient Display (n=7) and a subset of studies (n=34) that discuss the theory or classification of the technology.

Found within these studies were 459 Ambient Displays that were classified according to three general attributes which were found to reoccur across these implementations. These attributes were the modality, the physical form and the level of interaction designed for each of these displays. These document references, the data used in Figures 1-3 and discussed in this paper have been made available in a public data repository for open access [31].

### IV. DISPLAY MODALITIES

Almost since the beginning of Ambient Display in 1996 [8], there has been the associated notion of Ambient Media [44]. This has implied that diverse modalities might be used to encode data and display information across a range of senses. As might be expected, across the 459 Ambient Displays the modalities were diverse [31] (see Figure 1). Although, only about 12% of these were identified as multimodal displays (n=54). By contrast, 76% of the displays provided only a light-based mode, implemented using physical lights, projected images or traditional computer screens (n=348). Other approaches included object movement (n=32), sound (n=12), olfaction (n=2) temperature (n=2) or vibration (n=9).

In total, 87% (n= 398/459) of the reviewed systems were found to use some form of light for output. The majority (n= 348) of these implementations used light as the single output medium. A smaller subset of displays (n=49) incorporated light as part of a multimodal presentation. While the use of light was the primary media used for output, some systems adopted more novel modalities, including the use of smell

## Ambient Display - Modality 1996-2016

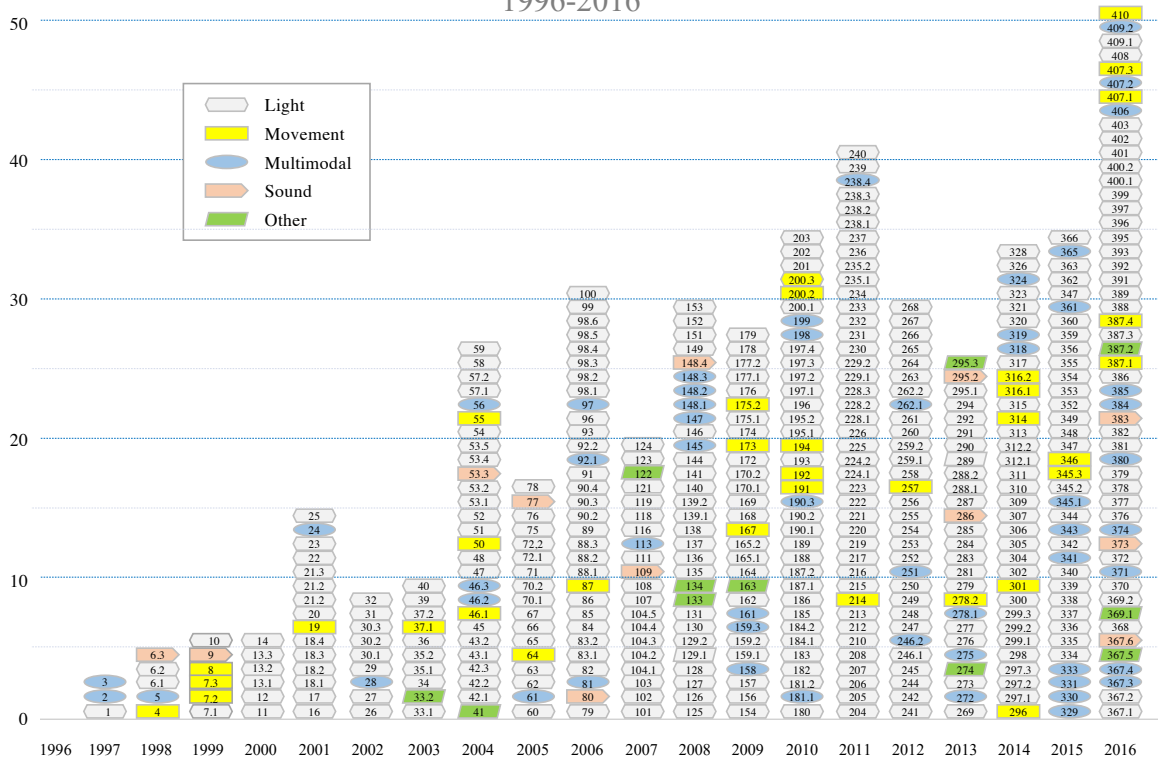

Figure 1. Distribution of Ambient Displays over time, classified by modality. The numbers directly reference identifiers in the systematic review data [31]

(n=3), sound (n=53), vibration (n=13) and temperature (n=6). These novel displays often depart significantly from typical computer systems.

In the scope of this review, only a few implementations were identified that solely make use of sound for output (n=12). This result is somewhat unexpected given the ambient nature of sound and the opportunities afforded by sonification that allows encoding of abstract data into non-speech sounds [45].

### V. PHYSICAL FORM

The review also identified a broad range of physical forms that could be described in two general categories. Firstly, there are those that make use of screen or projection technology for output. Alternatively, there are displays that are more tangible or sculptural in form and are categorized as object-based Ambient Displays. The distribution of these two different hardware types was largely even across the domain with 49% (n=224/459) being screen-based and 51% (n=235/459) being tangible display objects (see Figure 2).

These screen-based implementations typically used off-the-shelf LCD, CRT monitors or projection technology. Computer-driven displays permit considerable flexibility around the selected data mapping. These screen-based displays tend to use either natural metaphors or symbols for

encoding data. The focus tends to be in mapping layers of information into art-like compositions, typically in the form of pictures or posters [6]. Often these systems adopt a wall-based, ‘Informative Art’ approach [6].

This Informative Art approach is well documented where screen-based technologies are typically used to visualize a live data source by enhancing the attributes of an existing artwork. For example, the work of Piet Mondrian has been the inspiration for a dynamic display where the volume of email received is represented through the size of colored shapes [6].

Around 51% of all reviewed Ambient Displays were found to make use of tangible objects. Given their sculptural nature these displays were found to take numerous forms and use a range of modalities. The distribution of modalities across object-based displays was similar to the domain as a whole, with a high proportion of light-based systems.

Due to their physical nature, these displays are also referred to as being sculptural in form [3] and could be classified as Tangible User Interfaces [35]. This group of Ambient Displays are implemented using diverse hardware that ranges from augmented household objects through to more complex custom-built artefacts. The creation of these

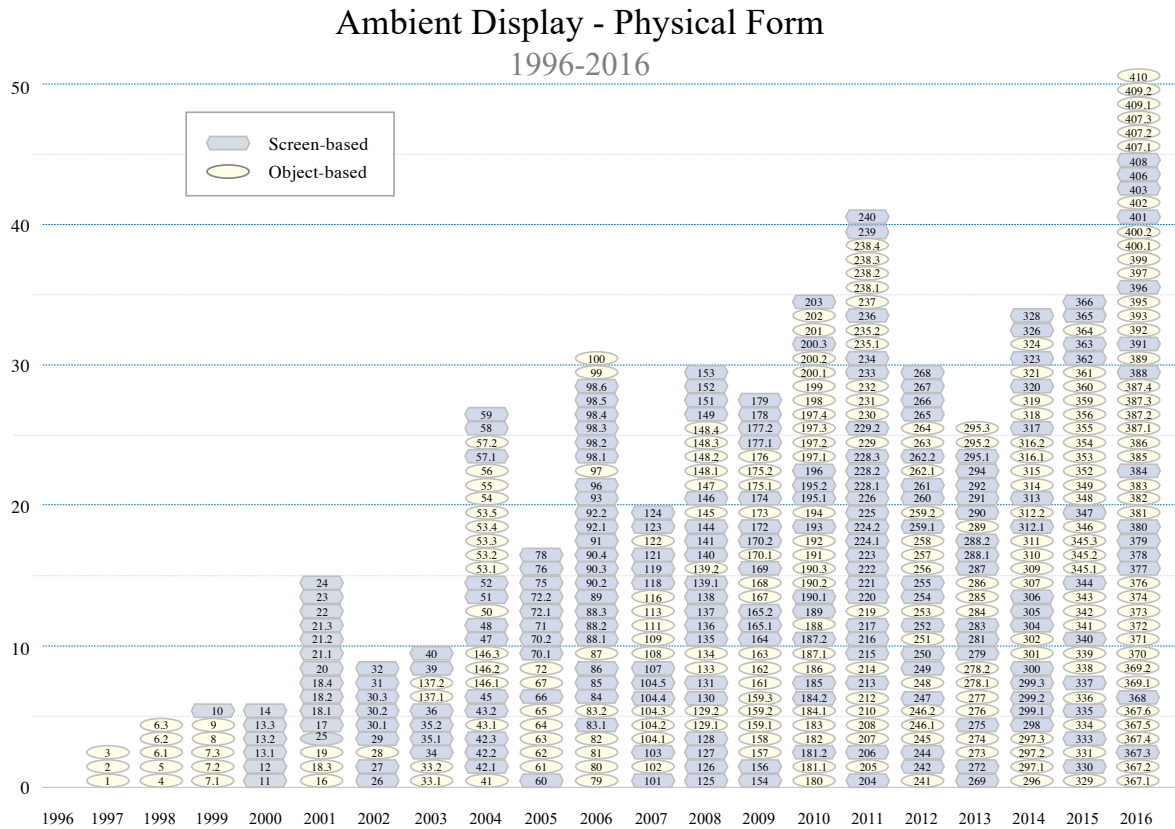

Figure 2. Distribution of Ambient Displays classified by physical form. Numbers directly reference identifiers in the systematic review data [31]

displays typically combines off-the-shelf technologies or requires custom hardware to be built. Unlike screen-based displays, the amount of information that can be displayed on object-based displays is usually limited as these displays only support a few attributes of information [3]. As a result, the time and effort required to build these tangible objects may be greater than using off the shelf display hardware, although more tangible forms may allow for a further subtle visualization through display mechanisms that may not be light based. This approach is well documented in an early example of the technology, the ambientROOM where sound and object-based projections are used to visualize data [35].

### VI. INTERACTIVITY

Ambient Displays are typically designed to function with no direct input from the user. This non-interrupting, approach follows the basic tenants of Calm Technology. Therefore, these displays might be expected to remain fully ambient and only output information. However, some systems while predominantly ambient, also support a low level of direct interaction. In contrast to fully ambient

systems, displays that provide a minimal level of interactivity are classified as semi-ambient.

The systematic survey identified 58% (n=266/459) of the reported systems as fully ambient, accepting no input from the user. Such systems, by design are intended to not interrupt the user’s primary attention and remain peripheral. Many of the traditional examples of Ambient Displays, such as the Dangling String [8] have no direct interaction. They reside within their environments presenting information without need or support for user input.

Despite this non-interactive expectation, the inclusion of active or passive interaction features were still reasonably common (42%, n=193/459). These semi-ambient systems still aim to remain peripheral but possess interactive capabilities that may move the system to the centre of the user’s attention for short periods of time. The intent is to allow momentary interaction from the user so they can configure, enhance or in some other way manipulate the function of the display. For example, to change the display features, connect to another data source, or change the data mappings.

## Ambient Display - Interaction 1996-2016

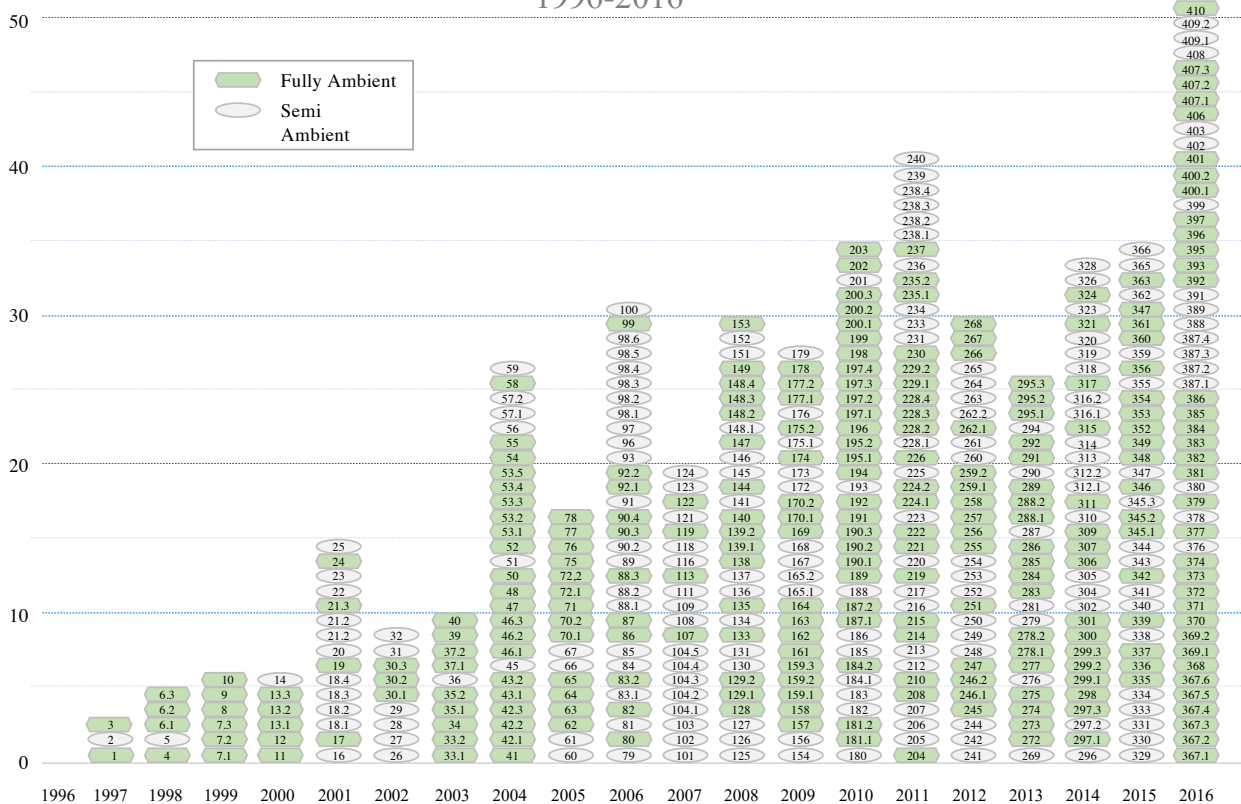

[49], presenting peripheral information through emerging augmented reality technologies [50], visualising heart rate through a light emitting wearable device [51], displaying information through plant [52] or human [53] shadows and to engage people with dementia through Ambient Displays [54]. While these recent developments in the field are indicative of the technologies covered in this review an analysis of literature from 2017 and onwards represents an opportunity for further research.

When categorizing the Ambient Displays by form about half of the displays used standard screen-based display technology, while the other half were based on tangible everyday objects. There is a clear divide here between the two types of display. Two distinguishing features of these groups are the greater complexity of information that can be displayed using screen-based devices and the limited range of information opportunities and bespoke development requirements for tangible objects.

The final category considered interaction level and identified 58% of the displays to be fully ambient while 42% provided some low-level of interaction. In terms of utility, the non-interactive displays are most aligned to the principles of Calm Computing, as the user is not distracted from their primary task by engaging with the display. The inclusion of interactive features may seem counterintuitive to the creation of peripheral technologies. However, these systems usually try to adhere to the tenets of the Calm Computing by limiting the frequency of interaction, allowing voluntary interaction or providing more passive methods of interfacing.

In addition to these themes, it was found that most of the Ambient Display literature simultaneously considers the design, development and evaluation of the technology (n=254). This results in limited studies relating to non-implementation specific evaluation methods and literature discussing the theory underpinning the field. In this sense, there would be opportunity for further research regarding these more theoretical areas of the domain in a field dominated by practice-based studies.

#### REFERENCES

- [1] B. Shelton and K. Nesbitt, "The Aesthetic Awareness Display: A New Design Pattern for Ambient Information Systems" ACSW '16, ACM, Feb. 2016, pp. 501-511, doi:10.1145/2843043.2843371.
- [2] J. Mankoff et al., "Heuristic Evaluation of Ambient Displays" CHI '03, ACM, Apr. 2003, pp. 169-176, doi:10.1145/642611.642642.
- [3] Z. Pousman and J. Stasko, "A Taxonomy of Ambient Information Systems: Four Patterns of Design" AVI '06, ACM, May 2006, pp. 67-74, doi:10.1145/1133265.1133272.
- [4] M. Ames and A. Dey, "Description of Design Dimensions and Evaluation for Ambient Displays" 2002, <http://www2.eecs.berkeley.edu/Pubs/TechRpts/2002/6193.html> [retrieved: August, 2020]
- [5] T. Matthews, A. Dey, J. Mankoff, S. Carter, and T. Rattenbury, "A Toolkit for Managing User Attention in Peripheral Displays" UIST '04, ACM, Oct. 2004, pp. 247-256, doi:10.1145/1029632.1029676.
- [6] J. Redström, T. Skog, and L. Hallnäs, "Informative Art: Using Amplified Artworks As Information Displays" DARE '00, ACM, Apr. 2000, pp. 103-114, doi:10.1145/354666.354677.
- [7] B. Otjacques and F. Feltz, "Redesign of Classic Information Visualization Techniques in an Artistic Computing Perspective" APGV '07, ACM, Jul. 2007, pp. 131-131, doi:10.1145/1272582.1272608.
- [8] M. Weiser and J. Brown, "Designing Calm Technology", *Powergrid Journal*, Vol. 1, 1996, doi:10.1.1.123.8091.
- [9] J. McCarthy, T. Costa, and E. Liongosari, "Unicast, outcast & groupcast: Three steps toward ubiquitous, peripheral displays" *UbiComp 2001*, Oct. 2001, pp. 332-345, doi:10.1007/3-540-45427-6\_28.
- [10] M. Rodríguez, J. García-Vázquez, and Á. Andrade, "Design Dimensions of Ambient Information Systems to Facilitate the Development of AAL Environments" *PETRA '11*, ACM, May 2011, pp. 41-47, doi:10.1145/2141622.2141627.
- [11] M. Pielot and R. Oliveira, "Peripheral Vibro-tactile Displays" *Mobihci '13*, ACM, Aug. 2013, pp. 1-10, doi:10.1145/2493190.2493197.
- [12] D. Saha and A. Mukherjee, "Pervasive computing: a paradigm for the 21st century", *Computer*, vol. 36, pp. 25-31, Mar. 2001, doi:10.1109/MC.2003.1185214.
- [13] D. Russell, N. Streitz, and T. Winograd, "Building Disappearing Computers", *Communications of the ACM*, vol. 48, pp. 42-48, Mar 2005, doi:10.1145/1047671.1047702.
- [14] N. Streitz, C. Magerkurth, T. Prante, and C. Röcker, "From Information Design to Experience Design: Smart Artefacts and the Disappearing Computer", *Interactions*, vol. 12, pp. 21-25, Jul. 2005, doi:10.1145/1070960.1070979.
- [15] N. Streitz et al., "Designing smart artifacts for smart environments", *Computer*, vol. 38, pp. 41-49, Apr. 2005, doi:10.1109/MC.2005.92.
- [16] A. Moere, "Aesthetic data visualization as a resource for educating creative design" *Caadutures Conference*, Springer, 2007, pp. 71-84, doi:10.1007/978-1-4020-6528-6\_6.
- [17] A. Ferscha, "A Matter of Taste" *Ami'07*, Springer-Verlag, Nov. 2007, pp. 287-304, doi:10.1007/978-3-540-76652-0\_17.
- [18] A. Ferscha, "Informative art display metaphors" *UAHCI 2007*, Springer, 2007, pp. 82-92, doi:10.1007/978-3-540-73281-5\_9.
- [19] A. Moere, "Beyond the tyranny of the pixel: Exploring the physicality of information visualization" *International Conference on Information Visualisation (IV)*, IEEE, Jul. 2008, pp. 469-474, doi:10.1109/IV.2008.84.
- [20] K. MacLean, "Putting haptics into the ambience", *IEEE Transactions On Haptics*, vol. 2, pp. 123-135, Jul. 2005, doi:10.1109/TOH.2009.33.
- [21] M. Hohl, "Beyond the screen: visualizing visits to a website as an experience in physical space", *Visual Communication*, vol. 8, pp. 273-284, Aug. 2008, doi:10.1177/1470357209106469.
- [22] A. Moere and D. Offenhuber, "Beyond ambient display: a contextual taxonomy of alternative information display", *International Journal Of Ambient Computing and Intelligence (IJACI)*, vol. 1, pp. 39-46, 2009, doi:10.4018/jaci.2009040105.
- [23] Z. Pousman, J. Stasko, and M. Mateas, "Casual information visualization: Depictions of data in everyday life", *IEEE*

- Transactions On Visualization And Computer Graphics, vol. 13, pp. 1145-1152, Nov. 2007, doi:10.1109/TVCG.2007.70541.
- [24] M. Mulvenna et al., "Visualization of data for ambient assisted living services", IEEE Communications Magazine, vol. 49, pp. 110-117, Jan. 2011, doi:10.1109/MCOM.2011.5681023.
- [25] R. Vatavu, "On designing interactivity awareness for ambient displays", Multimedia Tools And Applications. vol. 66, pp. 59-80, Jun. 2012, doi:10.1007/s11042-012-1140-y.
- [26] Q. Sheng, E. Shakshuki, and J. Ma, "User-centric ambient information systems and applications", Personal And Ubiquitous Computing, vol. 18, pp. 819-820, Jun. 2013, doi:10.1007/s00779-013-0693-8.
- [27] L. Bartram, "Design challenges and opportunities for eco-feedback in the home", IEEE Computer Graphics And Applications, vol. 35, pp. 52-62, Jul. 2015, doi:10.1109/MCG.2015.69.
- [28] A. Löcken, W. Heuten, and S. Boll, "Enlightening Drivers: A Survey on In-Vehicle Light Displays" Automotive'ui 16, ACM, Oct. 2016, pp. 97-104, doi:10.1145/3003715.3005416.
- [29] G. Khut, "Designing Biofeedback Artworks for Relaxation" CHI EA '16, ACM, May 2016, pp. 3859-3862, doi:10.1145/2851581.2891089.
- [30] S. Clinch, J. Alexander, and S. Gehring, "A survey of pervasive displays for information presentation", IEEE Pervasive Computing, vol. 15, pp. 14-22, Jul. 2016, doi:10.1109/MPRV.2016.55.
- [31] B. Shelton and K. Nesbitt, "Categorised Ambient Displays published between 1996 and 2016 and identified in a systematic review", 2019, Mendeley Data. <http://dx.doi.org/10.17632/m8zww4jdwrl> [retrieved: August, 2020]
- [32] D. Börner, M. Kalz, and M. Specht, "Beyond the channel: A literature review on ambient displays for learning", Computers & Education, vol. 60, pp. 426-435, Jan. 2013, doi:10.1016/j.compedu.2012.06.010.
- [33] D. Börner, M. Kalz, and M. Specht, "Closer to You: Reviewing the Application, Design, and Evaluation of Ambient Displays", International Journal Of Ambient Computing And Intelligence (IJACI), vol. 5, pp. 16-31, Jul. 2013, doi:10.4018/ijaci.2013070102.
- [34] A. Matviienko et al. "Towards new ambient light systems: a close look at existing encodings of ambient light systems", Interaction Design And Architecture, vol. 26, pp. 10-24, 2015, <http://hdl.handle.net/10230/32457> [retrieved: August, 2020]
- [35] H. Ishii and B. Ullmer, "Tangible Bits: Towards Seamless Interfaces Between People, Bits and Atoms" CHI '97, ACM, Mar. 1997, pp. 234-241, doi:10.1145/258549.258715.
- [36] F. Hemmert, S. Hamann, M. Löwe, J. Zeipelt, and G. Joost, "Weight-shifting mobiles: two-dimensional gravitational displays in mobile phones" CHI EA '10, ACM, Apr. 2010, pp. 3087-3092, doi:10.1145/1753846.1753922.
- [37] J. Stasko, T. Miller, Z. Pousman, C. Plaue, and O. Ullah, "Personalized Peripheral Information Awareness Through Information Art" Ubicomp 2004, Sep. 2004, pp. 18-35, doi:10.1007/978-3-540-30119-6\_2.
- [38] X. Shen, A. Moere, P. Eades, and S. Hong, "The long-term evaluation of Fisherman in a partial-attention environment" BELIV '08, ACM, Apr. 2008, pp. 1-6, doi:10.1145/1377966.1377979.
- [39] A. Meschtscherjakov, W. Reitberger, M. Lankes, and M. Tscheligi, "Enhanced shopping: a dynamic map in a retail store" Ubicomp '08, ACM, Sep. 2008, pp. 336-339, doi:10.1145/1409635.1409680.
- [40] S. Lee, K. Song, J. Kim, and J. Choi, "Ambient widget: An ambient information system using gesture-based interactions" Nbis 2012, IEEE, Sep. 2012, pp. 703-708, doi:10.1109/NBiS.2012.148.
- [41] J. Downs, B. Plimmer, and J. Hosking, "Ambient awareness of build status in collocated software teams" ICSE '12, IEEE, Jun. 2012, pp. 507-517, doi:10.1109/ICSE.2012.6227165.
- [42] N. Streitz, "It's All in the (ambient) Environment: Designing Experiences in Ubiquitous Hybrid Worlds" International Symposium On Ubiquitous Virtual Reality (ISUVR 2008), IEEE, Jul. 2008: pp. 1-4, doi:10.1109/ISUVR.2008.26
- [43] F. Alt et al., "Exploring ambient visualizations of context information" PERCOM2010, IEEE, Mar. 2010, pp. 788-791, doi:10.1109/PERCOMW.2010.5470542.
- [44] H. Ishii et al. "ambientROOM: integrating ambient media with architectural space", CHI '98, ACM, Apr. 1998, pp. 173-174, doi:10.1145/286498.286652.
- [45] H. Song and K. Beilharz, "Aesthetic and Auditory Enhancements for Multi-stream Information Sonification" DIMEA '08, ACM, Sep. 2008, pp. 224-231, doi:10.1145/1413634.141367
- [46] M. Hoggenmueller, A. Wiethoff, and M. Tomitsch, "Designing Low-Res Lighting Displays as Ambient Gateways to Smart Devices", International Symposium on Pervasive Displays (PerDis '18), ACM, Jun. 2018, pp. 1-8, doi:10.1145/3205873.3205876.
- [47] B. Yu, J. Hu, M. Funk, and L. Feijs, "DeLight: biofeedback through ambient light for stress intervention and relaxation assistance" Personal And Ubiquitous Computing, vol. 22, pp. 787-805, May 2018, doi:10.1007/s00779-018-1141-6
- [48] P. Haimes, T. Baba, H. Suda, and K. Kushiya, "Fuji-Chan: A Unique IoT Ambient Display for Monitoring Mount Fuji's Conditions" Multimedia Systems Conference (MMSys'17), ACM, Jun. 2017, pp. 246-249, doi:10.1145/3083187.3083223.
- [49] H. Sandhaus and E. Hornecker, "A WOZ Study of Feedforward Information on an Ambient Display in Autonomous Cars" The 31st Annual ACM Symposium on User Interface Software and Technology, ACM, Oct. 2018, pp. 90-92, doi:10.1145/3266037.326611.
- [50] R. Hammady, M. Ma, and C. Strathearn, "Ambient Information Visualisation and Visitors' Technology Acceptance of Mixed Reality in Museums" Journal on Computing and Cultural Heritage, vol. 9, pp. 22-23, Jun. 2020, doi:10.1145/3359590.
- [51] Ç. Genç, Y. Ekmekçioğlu, F. Balci, H. Ürey, and O. Özcan, "Howel: A Soft Wearable with Dynamic Textile Patterns as an Ambient Display for Cardio Training" CHI EA '19, ACM, May 2019, pp. 1-6, doi:10.1145/3290607.3312857.
- [52] A. Colley, Ö. Raudanjoki, K. Mikkonen, and J. Häkkinä, "Plant Shadow Morphing as a Peripheral Display" Proceedings of the 18th International Conference on Mobile and Ubiquitous Multimedia (MUM '19), ACM, Nov. 2019, pp.1-5, doi: 10.1145/3365610.3368410.
- [53] Ö. Raudanjoki, J. Häkkinä, K. Hurtig, and A. Colley, "Perceptions of Human Shadow Manipulation as an Ambient Display" 9th ACM International Symposium on Pervasive Displays, ACM, Jun. 2020, pp. 71-77, doi: 10.1145/3393712.3395180.
- [54] Y. Feng et al., "LiveNature: Ambient Display and Social Robot-Facilitated Multi-Sensory Engagement for People with Dementia" 9th ACM International Symposium on Pervasive Displays, ACM, Jun. 2020, doi:10.1145/3322276.3322331.

# Social Interactions of Artificial Ventilated Patients in Intensive Care – an Example of a Monitoring System

Jan Hendrik Röhl

Assistance Systems and Medical Device Technology  
 Carl von Ossietzky Universität Oldenburg  
 Oldenburg, Germany  
 email: jan.hendrik.roehl@uol.de

Alexander Gerka

Health / Automation and Integration Technology  
 OFFIS e. V.  
 Oldenburg, Germany  
 email: alexander.gerka@offis.de

Rebecca Diekmann

Assistance Systems and Medical Device Technology  
 Carl von Ossietzky Universität Oldenburg  
 Oldenburg, Germany  
 email: rebecca.diekmann@uol.de

Andreas Hein

Assistance Systems and Medical Device Technology  
 Carl von Ossietzky Universität Oldenburg  
 Oldenburg, Germany  
 email: andreas.hein@uol.de

**Abstract**—Only qualitative data on social interactions between ventilated patients and their caregivers and families are available from interviews. To improve sociological research in this highly sensitive setting, a concept of an observation system is described and presented. The system will be autonomous and is designed to collect information for a better understanding of the impact of using autonomous life-supporting systems like mechanical ventilation on the social system family with as minimal interfering as possible to the considered framework. From the analysis of the pilot study a multi sensor system, which combines Kinect, infrared-array and sound pressure data of a happening social interaction, is derived.

**Keywords**—social interaction; multi sensor system; intensive home care; artificial / mechanical ventilation.

## I. INTRODUCTION

The demographic change with an increasing number of older people and people with the need of care leads to a rising importance of home care services and understanding of the environment of the patients, their families and nursing staff. In addition, as people get older, the probability of being in need of care rises [1]. In Germany, 76% (2.59 million) of people in need of long-term care were treated outpatient in 2017 [1]. Figure 1 shows the increasing number of ventilated patients in Germany, which emphasizes the implication of a growing need for services in intensive care. Lloyd-Owen et al. (2005) identified a prevalence of 6.6 out of 100,000 people in Europe are mechanically ventilated at home [2].

An impact of the affinity to human likeness of assistive devices like prosthetic hands has already been described elsewhere [4]. The uncanny valley theory describes that the human likeness and affinity of industrial robots is low [4]. Moreover, a toy robot can represent a medium human likeness and affinity. Whereas, the human likeness of prosthetic hands is high, the affinity is very low. In addition, a healthy person is highly human like with a high affinity [4]. This theory of description might also be applied for other life supporting systems like mechanical ventilation devices, which changes the perception of the patient in need of intensive care to their environment. It

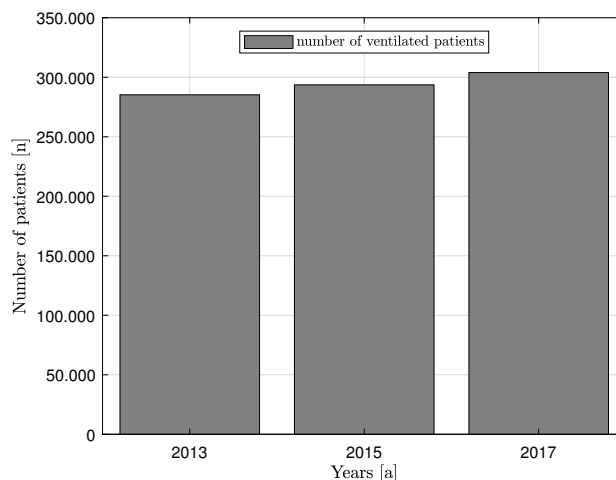

Fig. 1. The increasing number of ventilated patients in Germany [5].

might additionally be implied that the social family system and in particular the social interactions within the family and/or caregivers might be influenced by the mechanical ventilation. So far, no studies have been published in this regard.

Regarding quality of life of invasive ventilated patients, only few studies are available [6]–[9]. To our knowledge, no studies dealt with the social life of the ventilated patients, but with the safety of these patients [10]–[14].

At this point it remains unclear, to what extent intensively-cared patients or which dimensions of technical realization of autonomously life-supporting systems change the embeddedness of patients in the family context [15].

Artificial invasive ventilated patients are an example for people in need of long-term care. [3] describes the connection of social interaction and nursing procedures as a strong link. Therefore, they cannot be considered as separated actions.

In Section II, the method is described with the individual components (pilot study, measurement setup and video analysis). The results are discussed in Section III, additionally a concept to collect more detailed information about social

interactions in the context of mechanical ventilated patients with intensive care staff, therapists for artificial ventilation and in the best case a social family system is proposed in Section IV. It has to be kept in mind that most invasive ventilated patients spend most of their time in bed, which is caused by their disability and/or the severity of the disease [13]. Therefore, adapted configurations for the novel system are described, which provide the patients intimacy. This is followed by the conclusion, in Section V.

## II. METHODS

A detailed description of the conducted pilot study, measurement setup follows. In addition, the analysis of the generated data is discussed.

### A. Pilot Study

The pilot study was conducted with two professional therapists for artificial ventilation. These therapists performed the process of suction via tracheostomy tube and the change of the tracheostomy tube on a training mannequin (Resusci Anne). The tracheostomy tube provides a bypass of the larynx and pharynx area of the throat and is used for the invasive mechanical ventilation of a patient [16]. In addition, the process of suction via tracheostomy tube was also performed on a participant. These nursing processes were in the focus of this pilot study as they represent typical nursing procedures for invasive ventilated patients [17] [18].

TABLE I  
MEASURED NURSING PROCEDURES AND CONSTELLATIONS

Procedure	RGB-D pos.	Subject	Caregivers	Repetitions
Suction	1	Mannequin	1	7
Suction	1	participant	1	5
Change	2	Mannequin	1 and 2	5

In total, 29 minutes and 45 seconds of data within 17 videos (see Table I) were recorded during this pilot study.

### B. Measurement Setup

In the pilot study, a depth camera (RGB-D), Microsoft Kinect v2.0, was used for data collection. During the measurements only the points cloud and joint positions were stored. The RGB-D sensor was placed in two different positions around the patient’s bed, as shown in Figure 2.

The first position was used during the process of suction via tracheostomy tube, which was performed by one professional caregiver. In addition, the second sensor position was used during the process of tracheostomy tube change. This position was selected based on the fact that two professional caregivers were executing the tracheostomy tube change together, so that the RGB-D sensor in position one would have been covered by a caregiver.

### C. Video Analysis

The recorded RGB-D data was analyzed independently by two researchers to determine the patterns of social interactions between the patient and caregiver. Therefore, the data was analyzed by searching for typical patterns and the orientation

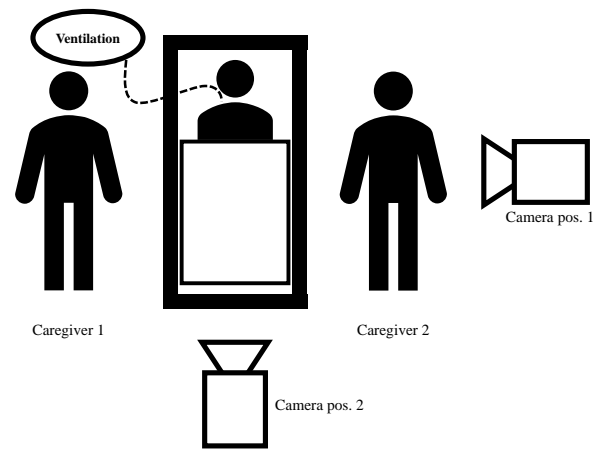

Fig. 2. Positions of the RGB-D sensor and the caregivers during the pilot study.

of the caregivers to the participant or training mannequin.

The videos were analyzed regarding the following questions:

- Which patterns represent social interactions?
- Which patterns represent typical nursing procedures?

During the acquisition, only the point clouds of the RGB-D sensor were saved. The Microsoft Kinect Studio v2.0 delivers the joint positions out of the point clouds.

## III. RESULTS

The processes were divided in two different nursing procedures. In Figure 3 and Figure 4, the red lines illustrate the skeleton of the caregiver and the white circle, square and triangle present the joint positions, delivered by the Microsoft software Kinect Studio v2.0. The collected data of the pilot study shows repetitive patterns during the nursing processes of suction via tracheostomy tube and the change of the tracheostomy tube. The differences of these procedures are discussed below.

### A. Suction via Tracheostomy tube

Figure 3 presents and describes the process of suction via tracheostomy tube. This process was performed at a participant by a therapist. As shown in Figure 2, camera position 1 is used to document this procedure. The skeleton and joint positions, delivered by the software, are stable for the upper parts, but not the (for this process irrelevant) lower body parts, due to the shadow of the bed, which was placed between the caregiver and the RGB-D sensor (Figure 3).

The process starts with disinfecting the hands, where the caregiver was averted from the participant. Afterwards, the caretaker puts on rubber gloves and a mask, also averted from the participant. The suction hose gets connected and the caregiver puts on an additional sterile glove, while facing the participant. The mechanical ventilation gets disconnected and the actual process of suction via tracheostomy tube is performed, the caregiver is as well facing the participant. Then the mechanical ventilation gets reconnected and the caregiver is cleaning up, still facing the participant. The last step is the



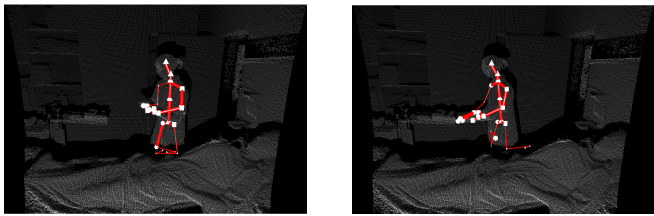

1. Disinfecting the hands. Averted from the participant.

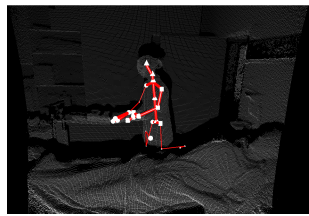

2. Putting on the rubber gloves. Averted from the participant.

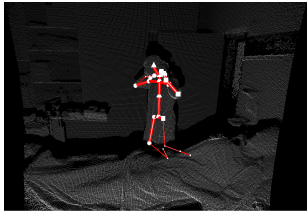

3. Putting on the mask. Averted from the participant.

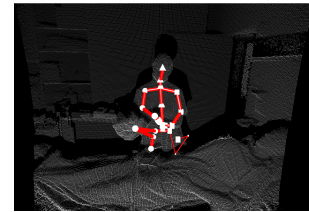

4. Connecting the suction hose and putting on sterile glove. Facing the participant.

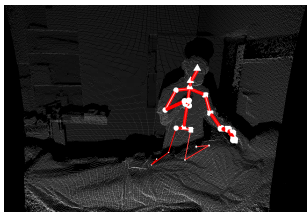

5. Disconnection of mechanical ventilation. Facing the participant.

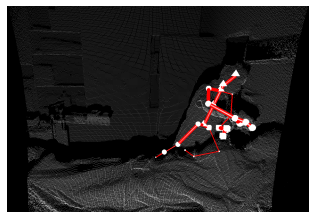

6. Process of suctioning via tracheostomy tube. Facing the participant.

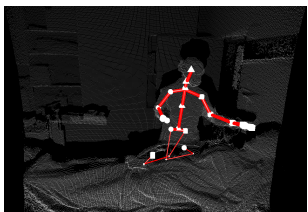

7. Reconnecting of mechanical ventilation and cleaning up. Facing the participant.

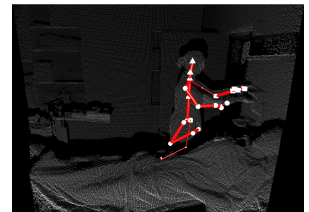

8. Disinfecting the hands. Averted to the participant.

Fig. 3. Process of suction via tracheostomy tube.

disinfection of the caregivers hands, while averted from the participant.

As shown in Table II, an interesting behavior by the nursing staff executing the process of suction via tracheostomy tube at a participant or training mannequin was found. In this study, the caregivers were averted from the participant during the process of hand disinfection before executing the process of suction via tracheostomy tube four out of five times, whereas the training mannequin was faced by the nursing staff five out of seven times and the nursing staff was averted only one time.

Being averted from the patient suggests that there is no evidence of social interaction based on data from a RGB-D

TABLE II  
ORIENTATION OF THE CAREGIVER IN RELATION TO THE PARTICIPANT DURING THE PROCESS OF HAND DISINFECTION.

Type of patient	Orientation		
	Averted	Halfway facing	Facing
Training mannequin	1	1	5
participant	4	0	1

sensor.

### B. Tracheostomy tube change

Figure 4 shows the process of the tracheostomy tube change. For this nursing procedure, the camera position 2 was used and the caregiver 1 and caregiver 2 are performing the nursing procedure (as seen in Figure 4). In comparison, the nursing procedure of tracheostomy tube change is more complex than the procedure of suction via tracheostomy tube. In addition, the procedure of suction via tracheostomy tube is a sub-procedure of the tracheostomy tube change. The nursing procedure of suction via tracheostomy tube is performed by the caregiver 2, during the preparation of tracheostomy tube change by caregivers 1. Therefore, in Figure 4 only the steps of the tracheostomy tube change are presented. The change of the position of the RGB-D sensor did not lead to a better detection of the lower body skeleton of the both caregivers.

For the tracheostomy tube change the tracheal cuff gets unblocked and the tracheal collar is changed by caregiver 2, while caregiver 1 is preparing the actual process. Afterwards the process of suction via tracheostomy tube is performed by caregiver 2. Then the new tracheostomy tube is carried to the participant by caregiver 1 and the actual tracheostomy tube change is performed by both caregivers. After that caregiver 1 blocks the cuff and caregiver 2 puts the old tracheostomy tube away and reconnects the mechanical ventilation. Followed by auscultation with a stethoscope performed by caregiver 2 and caregiver 1 disconnects a syringe of the cuff. Finally, both caregivers clean up and get rid of the waste.

No evidence for other anomalies during this nursing procedure were found. Since there is no data of this procedure conducted on a participant, no difference in the behavior of the caregivers could be analyzed.

As no sound pressure was recorded, no evidence of spoken words or other vocal interaction between caregiver and participant as an element of social interaction is present, when being averted. Due to the fact that there is no information about any vocal interaction the mentioned assumption might not be true. With the aim to better understand the social interactions between participants and their families and caregivers in this sensitive operating field a new autonomous system to collect data is needed. In this concept, camera position 2 should be used, as this position covers the two nursing procedures observed in the pilot study. The following section presents and describes a promising concept for the collection of data set in a highly sensitive environment like the participant room of bedridden participants with the need of intensive care.

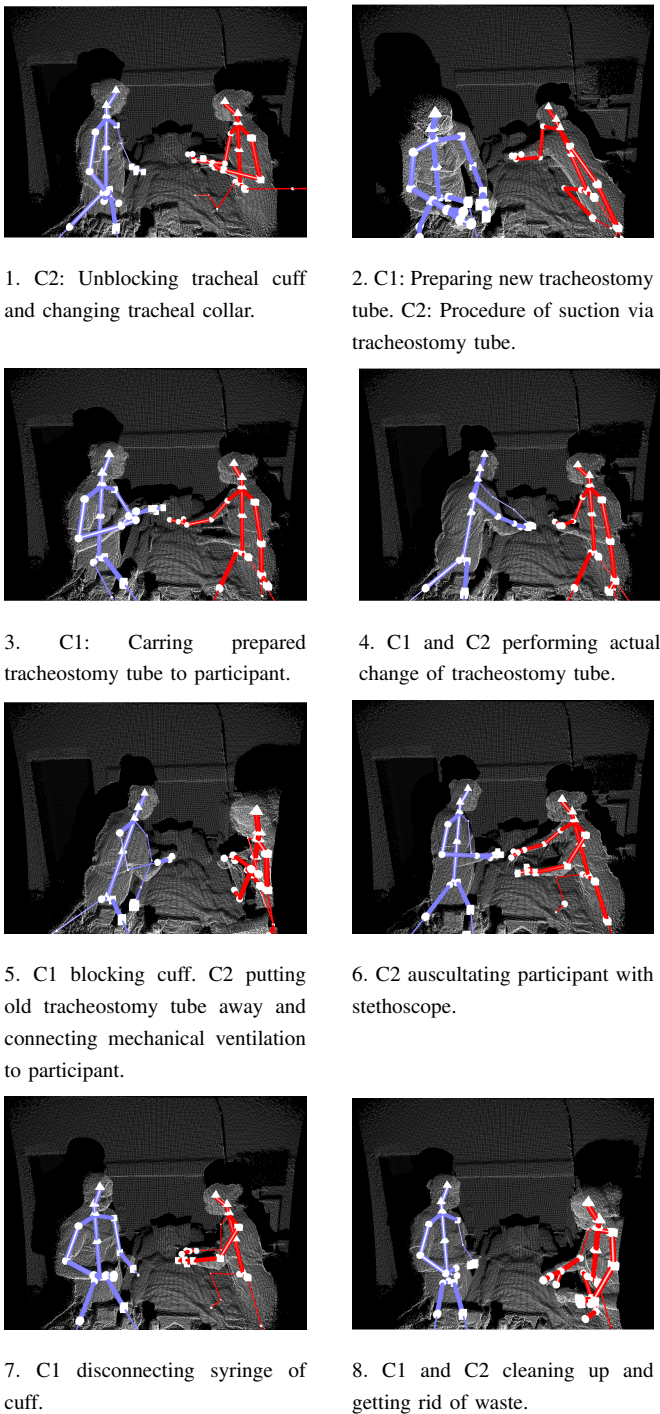

Fig. 4. Process of tracheostomy tube change.

IV. CONCEPT

This section describes a concept to collect combined data of infrared, RGB-D and sound pressure sensors from social interactions of bedridden patients. This system detects the quantity of interactions in the patient room. Further, the system will identify when and where the social interactions happen in the patient room.

Due to the high sensitivity of the environment in which the system will operate and collect information, a high standard to protect privacy and anonymity of the patients, their families

and caregivers must be ensured. In addition, there is the possibility to choose between three different modes. Firstly, there is a full recording mode, integrating all in the following described sensors. Secondly, during the limited recording only the infrared array sensor, sound pressure and the motion detection by the passageway and motion sensor is enabled to collect information. This mode will be implemented to collect information about sensitive interactions without recording of video data. The third mode is the passive mode, which disables the total system for a defined period of time.

The system is set up at the patient’s request, i.e., the patient can choose between the first and second mode as the activated standard mode. If the first mode is chosen as standard, the system can be switched into the second mode or disabled by the patient’s choice. In addition, if the second mode is chosen as standard mode, there will also be the possibility to disable the entire system for a defined period of time.

Therefore, it will be possible to deactivate the entire system via a wireless switch. This type of switch is used, because the system will initially not be installed as permanently. The system state (active/inactive) will be mirrored via a highly visible and clear to interpret display with appropriate symbols and colors.

The multi sensor system will consist out of sensors (hardware), special designed software for the sensor evaluation and a control system (software).

A. Sensors

In Table III, the sensors used in this setting with their assigned task are shown. The passageway sensor consists out of two light barriers, which allow to detect the direction of movement through the sensors field of view. The motion sensor reacts to the change of the infrared field in sight of the sensor. This sensor can detect motion in a certain area. In addition, the Grid-EYE infrared array sensor from Panasonic consists out of an 8x8 matrix infrared array, which delivers the temperature of each of the 64 measurement fields [19]. To protect the mentioned privacy a wireless switch will be installed near the door of the patient room, which can be used to deactivate the total system for a defined period of time. Further on, the sound pressure instrument is a microphone, which records the loudness of an event and not the actual noise. The Azure Kinect is a RGB-D sensor from Microsoft. This sensor consists out of a depth camera, RGB camera and infra red (IR) emitters [20].

TABLE III  
LIST OF SENSORS

Sensor	Function
Passageway sensor	Detect person entering/leaving the room
Motion sensor	Detect person in bed area
Grid-EYE	Detect number of people in the bed area
Wireless switch	Deactivation of the system
Sound pressure instrument	Detect vocal interactions
Kinect 4 Azure	Deliver basis for data labeling

B. Sensor tasks

The tasks mentioned in Table III can be differentiated in two groups: Firstly, in a group of different start trigger sensors

(see Table IV) to detect an event and start up the multi sensor system. Possible events, which trigger the start of the system are mentioned in Table IV. These kinds of events should accompany a social interaction at a high possibility, like entering the patient room. When the passageway sensor is located in the door frame, assumptions of people entering or leaving the patient room are possible. In interaction with the motion sensor, which is independent of the passageway sensor, general motions of infrared emitting objects in a certain area of the patient room can be detected. In addition, the permanent evaluation of the Grid-EYE data motion of heat sources can be detected and provide the possibility to identify a moving source of heat, which may lead to a possible social interaction.

TABLE IV  
LIST OF EVENTS USED FOR THE START TRIGGER.

Deployed sensors	Event trigger		
	Event	Start	Stop
Passageway sensor	Entering/leaving the room	x	x
Motion sensor	Movement in nursing area	x	
Grid-EYE	Min. 2 sources of heat in sight	x	
Wireless switch	Manual deactivation		x

Secondly, the recording of sensors can be grouped. Whenever one of the mentioned start triggers is detecting a possible social interaction, the recording sensors will start collecting data. In this case the recording sensors are the sound pressure instrument, the Grid-EYE and the RGB-D sensor. During the recording the Grid-EYE sensor is used to determine, whether a person is laying, sitting or standing in the sensor sight. The additional usage of a sound pressure instrument enables to distinguish whether a person is speaking or listening to music, for example. The RGB-D sensor in this setting is used to determine if the usage of a RGB-D sensor is needed or the Grid-EYE sensor is able to provide all needed information of movements and gestures to analyze social interactions. Using the RGB-D sensor in this setting might lead to a system that makes itself independent of a camera to analyze social interactions.

C. Process of Multi Sensor System

In this section the process chain of the multi sensor system is proposed. Due to the process chain in Figure 5, the privacy of the patient, caregiver and family will remain guaranteed.

Whenever one of the above described start triggers (see Table IV) detects an event, the collection of data will be started, if the system is not deactivated by the wireless switch. When the system is active and a start trigger is caused by an event the recording of the sound pressure, Grid-EYE sensor and RGB-D sensor will started, if there is more than one person in the room. In consideration to the high sensitivity of the operating environment the multi sensor system will additionally check the deactivation message/bit after each collected data frame. This way the deactivation message will be checked two times in different steps of the algorithm. If the algorithm is collecting data and the deactivation is true, the system will stop immediately the collection of data and will wait for a defined period of time to check for a new event detection of one of the start triggers. The defined period

of time should be long enough to execute sensitive nursing procedures or interactions in the patient environment.

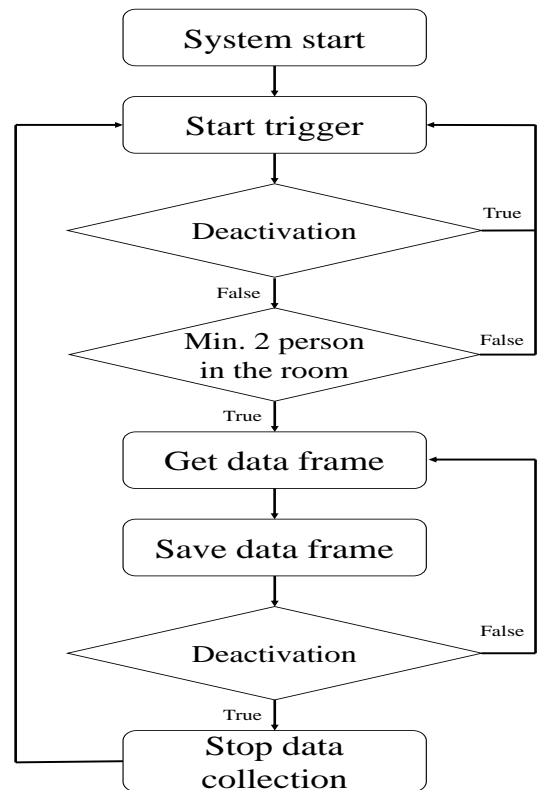

Fig. 5. Design of the proposed system process order to ensure the high sensitivity.

V. CONCLUSION

These findings are of great importance as they support the future development of home care systems and appreciation towards the patient in order to realize family-sensitive technical systems in the field of intensive care.

The importance of ambulant intensive care services, due to the demographic change with the increasing number of older people and the higher probability of older people to be in need of care and intensive ambulant care, is rising. We found a differentiation between handling a training mannequin and a participant. This findings lead to the assumption of using real patients in future work for further understanding of social interactions of mechanically ventilated patients. For a better understanding of the social interactions of patients, who are mostly bedridden, with their family system and caregivers a novel concept to collect information about social interactions is presented. The autonomous system will be used to understand the impact of using autonomous life-supporting systems like mechanically ventilation on the social system family with a minimal disturbance of the considered framework. The presented multi sensor system combines RGB-D, infrared-array and sound pressure data with the quantity of social interactions in a highly sensitive environment. In pursuing studies the sensors and their positions should be selected in consultation with the patient. In addition, a wireless deactivation switch

should be used to maintain the patient's intimacy and privacy. It should also be considered to only use skeleton data, like joint positions, in future studies. Due to the findings of this project we hope to contribute our part in creating a higher quality of life for these patients and their families.

#### ACKNOWLEDGMENT

This work was founded by the German Ministry of Education and Research (BMBF) within the joint project MeSiB grant 16SV7723 and the Research Training Group (RTG) "Social Embeddedness of Autonomous Cyber Physical Systems" (SEAS) funded by the Carl von Ossietzky University Oldenburg

#### REFERENCES

- [1] destatis.de, 'Press release No. 501 of 18 December 2018', Dec 2018. [Online]. Available: [https://www.destatis.de/EN/Press/2018/12/PE18\\_501\\_224.html](https://www.destatis.de/EN/Press/2018/12/PE18_501_224.html). [retrieved: 08, 2020].
- [2] S. J. Lloyd-Owen et al., "Patterns of home mechanical ventilation use in Europe: results from the Eurovent survey.," *European respiratory journal*, 2005, No. 6, pp. 1025-1031.
- [3] J.E. Seymour, "Critical moments—death and dying in intensive care." London: Sage, 2001.
- [4] M. Mori et al., "The uncanny valley," *Energy*, Vol. 7., Nr.4., 1970 p. 33-35, 1970.
- [5] de.statista.com, 'Number of severely disabled ventilated patients in Germany by type of functional impairment in the years 2013 to 2017', Jan 2019. [Online]. Available: <https://de.statista.com/statistik/daten/studie/247952/umfrage/anzahl-der-schwerbinderten-beatmungspatienten-nach-art-der-funktionsreinschraenkung/>. [retrieved: 08, 2020].
- [6] S. Euteneuer, W. Windisch, S. Suchi, D. Köhler, P. W. Jones, and B. Schönhofer, "Health-related quality of life in patients with chronic respiratory failure after long-term mechanical ventilation.," *Respiratory medicine*, 2006, Vol. 100., Nr. 3, pp. 477–486.
- [7] S. E. Huttman, F. S. Magnet, C. Karagiannidis, J. H. Storre, and W. Windisch, "Quality of life and life satisfaction are severely impaired in patients with long-term invasive ventilation following ICU treatment and unsuccessful weaning.," *Annals of intensive care*, 2018, Vol. 8., Nr. 1, pp. 38.
- [8] S. Smith and A. McLeod, "The effect of mechanical ventilation on quality of life in patients with motor neurone disease.," *British Journal of Neuroscience Nursing*, 2015, Vol. 11., Nr. 5, pp. 220-227.
- [9] J. Geiseler, O. Karg, S. Börger, K. Becker, and A. Zimolong, "Invasive home mechanical ventilation, mainly focused on neuromuscular disorders.," *GMS health technology assessment*, 2010, Vol. 6.
- [10] E. Lauta, C. Abbinante, L. Maiellaro, R. Rizzi, P. Dormio, and V. DeFilippis, "Improving Homecare Risk Management and Patient Safety.," *Epidemiology, Biostatistics and Public Health*, 2019, Vol. 16., Nr. 4
- [11] C. Schaepe and M. Ewers, "'I need complete trust in nurses'—home mechanical ventilated patients' perceptions of safety.," *Scandinavian journal of caring sciences*, 2017, Vol. 31., Nr. 4, pp. 948–956
- [12] A. Lang, N. Edwards, and A. Fleiszer, "Safety in home care: a broadened perspective of patient safety.," *International Journal for Quality in Health Care*, 2008, Vol. 20., Nr. 2, pp. 130–135
- [13] C. Lins et al., "Enhancing Safety of Artificially Ventilated Patients Using Ambient Process Analysis.," *MIE*, 2018, pp. 316–320.
- [14] W. S. Krinsky et al., "A model for increasing patient safety in the intensive care unit: increasing the implementation rates of proven safety measures.," *BMJ Quality & Safety*, 2009, Vol. 18., Nr. 1 pp. 74–80.
- [15] R. Evans et al., "Family caregiver perspectives on caring for ventilator-assisted individuals at home", *Canadian respiratory journal*, 2012, Vol. 19, Nr. 6, pp. 373-379.
- [16] R. F. Eisele, "Tracheostomy tube", U.S. Patent Nr. 5,067,496, 1991
- [17] P. A. Cazzolli and E. A. Oppenheimer, "Home mechanical ventilation for amyotrophic lateral sclerosis: nasal compared to tracheostomy-intermittent positive pressure ventilation.," *Journal of the neurological sciences*, 1996, Vol. 139, pp 123–128.
- [18] A. C. White, S. Kher, and H. H. O'Connor, "When to change a tracheostomy tube", *Respiratory Care*, 2010, Vol. 55., Nr. 8, pp. 1069–1075.
- [19] A. D. Shetty, Disha, B. Shubha, and K. Suryanarayana, "Detection and tracking of a human using the infrared thermopile array sensor—"Grid-EYE"™", 2017 International Conference on Intelligent Computing, Instrumentation and Control Technologies (ICICICT), pp. 1490–1495, 2017.
- [20] docs.microsoft.com, 'Azure Kinect DK hardware specifications', 2020. [Online]. Available: <https://docs.microsoft.com/en-us/azure/kinect-dk/hardware-specification>. [retrieved: 08, 2020].

## Effects of Indoor Environmental Quality on Concentration

Salla Muuraiskangas<sup>a</sup>, Heidi Similä<sup>a</sup>, Johanna Kallio<sup>a</sup>, Pauli Räsänen<sup>a</sup> and Kaisa Vehmas<sup>b</sup>

VTI Technical Research Centre of Finland Ltd.

a. Kaitoväylä 1, Oulu, Finland, b. Vuorimiehentie 3, Espoo, Finland

email: firstname.lastname@vtt.fi

**Abstract** – There is a lack of long-term research on the effects of indoor environmental quality on concentration in real environments using objective measurements. Concentration is an essential part of learning and processing information. Since pupils and students spend large parts of their days indoors, it can have major effects on their concentration. This paper presents an environmental monitoring system for collecting continuous indoor environmental quality data and studies the relationship between indoor environmental quality and pupil concentration in a real-life environment. An 18-week pilot was conducted in one school in Northern Finland during the autumn in 2018. Pupils (n=83) and teachers (n=4) in four classrooms participated in the study. Data on pupil concentration was collected twice a week via paper-format concentration tests. Additionally, teachers evaluated pupil concentration on a daily basis. A non-parametric correlation analysis (Spearman) was performed to investigate the associations between indoor environmental quality and pupil concentration. A statistically significant inverse association was found between pupil concentration and the relative humidity in all four classrooms, but no consistent associations with other indoor environmental quality parameters were found.

**Keywords**- indoor air quality; indoor environmental quality; concentration; school; pupil.

### I. INTRODUCTION

People spend most of their time indoors, and students and teachers spend a large portion of it in school buildings, up to 700 to 900 hours on average per year [1]. This is why the Indoor Environmental Quality (IEQ) notably affects public health. There are 76.1 million students [2] and 5.8 million teachers [3] in Europe spending time in school environments, which often have poor Indoor Air Quality (IAQ).

IEQ comprises air quality pollutants, mainly gases and particulates, and other factors, such as temperature, relative humidity, lighting, sound level and vibration [4]. The concentration of carbon dioxide (CO<sub>2</sub>) and Volatile Organic Compounds (VOCs) are well-known key parameters affecting IAQ [5]. Poor long-term IEQ is known to be associated with several health effects such as respiratory illnesses, allergic reactions, asthma, sick building symptoms, and reduced cognitive performance, which are estimated to generate high costs for society [6].

Concentration is essential for learning and performing school tasks. It is also highly important in information-intensive work. Concentration is affected by different environmental factors. It has been found that the IEQ affects pupils' cognitive performance when thermal conditions,

pollutants such as VOC, particles, and CO<sub>2</sub> levels were reviewed [7][8]. Moreover, inadequate IEQ can cause general symptoms, such as headaches, dizziness, tiredness, and eye complaints, which may have a direct effect on learning and, therefore, test performance [9]. Increased ventilation has been associated with pupils' faster performance in tasks [10][11] and more accurate responses [11]. In a study, where 70 elementary schools were monitored for a weeklong period, better mathematics test scores were found when ventilation rate was higher [12]. It seems that increased levels of CO<sub>2</sub> due to insufficient ventilation as well as thermal discomfort can reduce students' vigilance and concentration. However, all the previous experiments have been rather short-term and conducted in controlled environments. An 8-month study in a real office environment showed that perceived thermal discomfort, noise annoyance and lighting discomfort were associated with reduced work performance and objectively measured cognitive performance [13]. The study excluded objective measurements of the IEQ parameters as the study parameters, including temperature, light, sound, and performance, were measured with a self-reporting questionnaire. There is also evidence that noise can adversely affect children's learning [14]. Environmental factors have been found to cause diminished motivation, tiredness, and feelings of helplessness, which can result in reduced cognitive performance [13][15]. In contrast to this, natural light can improve students' concentration. However, the only study on this was based on students' perceptions of IEQ factors and lacked objective measurements of IEQ [16]. More long-term studies in real life environments with objective measurements would be required to confirm the results.

Measuring real-life IEQ should be non-invasive and continuous, but to date, real-time IEQ data with interpretable information have rarely been available. However, recent improvements in wireless and electronics technologies have enabled the development of low-cost, low-power, and multifunctional sensors, which can be embedded in environments and can provide new means to acquire real-time information about indoor conditions.

This paper describes an 18-week pilot which aimed to study associations between objective IEQ parameters and pupil concentration in an uncontrolled, real learning environment. Additionally, it describes an environmental monitoring system for measuring IEQ parameters, including: CO<sub>2</sub>, relative humidity, temperature, ambient lighting, sound levels, and an IAQ index. This paper is structured as follows: Section 2 describes the methods, Section 3 presents the results, which are discussed in Section 4, and Section 5 presents the conclusions.

II. METHODS

A. Pilot Environment

The 18-week pilot was carried out in a school in Northern Finland between August and December 2018. Four classrooms were monitored in two separate buildings. Building 1 was constructed in 1999 and building 2 was constructed in 1936 (renovated in 2005). The heating season started in the end of September. All the classrooms had a mechanical ventilation system, which the school personnel could not control. The ventilation rates in classrooms 1 to 4 were 8.6, 9.5, 10.0 and 11.9 L/s/person, respectively (Table I).

B. Participants

Four teachers and their 83 pupils (n=19+18+23+23=83) participated in the study. The average age of the teachers was 43.5 years and all of them were women. The average age of the pupils was 8.6 years. Of the pupils, 33 (39.8%) were girls and 50 (60.2%) boys. The teachers and pupils spent most of the school days in the same classroom during the study.

C. Data Collection

The data were collected from three sources: 1) IEQ sensors (IEQ data), 2) paper-format concentration tests performed by the pupils (pupil concentration data), and 3) an Android self-reporting application used by the teachers (teacher-reported pupil concentration data). The 18-week pilot contained 5 phases. In the 1st phase (2 weeks), the collection of the pupil concentration data was rehearsed. In the 2nd phase (6 weeks), the data collection (sources 1-3) was ongoing. Data collection continued until the end of the study. In the 3rd phase (3 weeks), the teachers were provided access to visualizations of IEQ data. In the 4th phase (3 weeks), air purifiers (UniqAir [17]) were brought into the classrooms (2 real, 2 mock-ups). In the 5th phase (4 weeks), the air purifiers were relocated so that each classroom had a real purifier in phase four or five.

1) Indoor Environmental Quality

All four pilot classrooms were equipped with an IEQ sensor system built of commercially available professional quality sensor devices. The temperature, relative humidity, CO<sub>2</sub>, ambient lighting and IAQ index were measured using MCF-LW12CO<sub>2</sub> environmental sensor devices [18]. The IAQ index represents breath Volatile Organic Compound (b-VOC) concentration for the most important compounds in the exhaled breath of humans and is the output of a proprietary algorithm for the Bosch BME680 VOC gas sensor [19]. The sound level was monitored with PeakTech PT8005 sound level meters [20].

TABLE I. CLASSROOM DESCRIPTIONS.

	Room 1	Room 2	Room 3	Room 4
Building	1	1	2	2
Pupils in the room	20	18	23	23
Area (m <sup>2</sup> )	59.7	59.7	49.8	64.2
Ventilation rate (L/s/m <sup>2</sup> )	3.0	3.0	4.8	4.4
Total ventilation (L/s/room)	180	180	240	285
Personal ventilation rate (L/s/person)	8.6	9.5	10.0	11.9

All the sensors were positioned according to the national legislative recommendations [21]. IEQ sensor devices were installed next to teacher’s post at about 1.1 meters above the floor level in the classrooms. Sound level meters were positioned in an open space at least 0.5 meters away from any obstacles, including but not limited to floors, walls, ceilings, and furniture, in the residence zone of the classrooms. The sampling rate was once per 15 minutes and 5 seconds for the MFC sensor and sound level meter, respectively. Data transfer from the MCF sensor devices to the Microsoft Azure cloud platform was set via a LoRaWAN gateway and from PeakTech devices using Raspberry PI (RPI) gateways. In the implemented IEQ system, message queue telemetry (MQTT) was the utilized data communication protocol from the IEQ gateways to the cloud service. All the sensor data were stored in the Microsoft Azure TableStorage. An overview of the system architecture and details on the sensor hardware are depicted in Figure 1 and Table II.

2) Pupil Concentration

The pupil concentration data was collected using a paper-format concentration test administered twice a week by the teachers. The concentration test had to be short (max. 5 min to administer), feasible for large group testing, performed without computers, suitable for children aged from 7 to 12 years, and suitable for repeated testing. Liukkonen [22] presented a test (numbers in a 10-by-10 grid from 1 to 100) that was considered feasible to administer by the teachers and could easily be varied by sorting numbers in a different order each time. A random generator was used to create unique number grids for each test. The pupils were given four minutes time to find numbers in numerical order. The duration was determined by two training tests with the pupils so it would not give too many close to zero or close to full scores. Teachers considered it infeasible to administer the concentration test more than twice a week (between Tuesday and Thursday). The test was conducted at the end of a 45-minute lesson, when teachers considered the entire class to be

TABLE II. DETAILS OF THE COLLECTED DATA.

Parameters	Source	Range	Accuracy	Sampling
Indoor Environmental Quality	Temperature	-10...60°C	±0.5°C	Every 15min
	Relative humidity	0...100%	±3% for 20...80% @25°C ±5% for 0...20% and 80...100% @25°C	
	CO <sub>2</sub>	300...5000 ppm	±50ppm + ±3% of reading	
	Ambient lighting	0.01...800 00lux	±15%	
	IAQ Index	1...500	±15% for b-VOC sensor 500...50000ppb	
Pupil concentration	PeakTech PT8005	30...130dB	± 1.4dB	Every 5s
Teacher-reported pupil concentration	Concentration tasks on paper	0...100	±1	Twice a week
	Android self-reporting app	1...5	±1	Daily

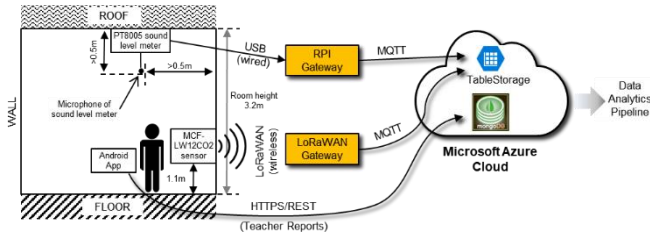

Figure 1. An overview of the data acquisition system used in the study.

in the classroom in order to maximize the number of the pupils and the time spent in the classroom. If there were changes in the school week, the test was conducted on another day or in another lesson if possible. Teachers reported any variance related to performing the test (day, contextual factors etc.). The number of girls and boys taking the test was recorded.

### 3) Teacher-Reported Pupil Concentration

A teacher-reported pupil concentration was the teachers' evaluation of the pupils' concentration during the day and it was collected every school day with an Android self-reporting application made by VTT Technical Research Centre of Finland Ltd (VTT). Teachers answered daily the question "How would you evaluate the concentration of the pupils today?" A 5-point answer scale was used consisting of the following options: 1) Extremely concentrated, 2) Concentrated, 3) Neutral, 4) Non-concentrated, 5) Extremely non-concentrated. The data were stored via an HTTP/REST interface in a MongoDB database in the Azure cloud (Figure 1).

## D. Data Analysis

### 1) Indoor Environmental Quality

The concentration tests were performed at the end of a 45-minute lesson. Thus, the average for the IEQ sensor parameters over a 45-minute time span before the test occasion was calculated and used in the analyses. The average was calculated for the temperature, relative humidity, CO<sub>2</sub>, ambient lighting, IAQ index, and two sound level sensors.

### 2) Pupil Concentration

The pupil concentration test results were converted to digital format by one researcher. The final score was the total number of the marked numbers. Among the test papers, there were a few zero results indicating that the subjects had given up, and few full scores indicating potential cheating. In some cases, the pupils were given more than 4 minutes by mistake, and therefore only the tests that were conducted exactly in four minutes were included in the analysis. Median, mean and trimmed mean values (excluding 25% of the outlying values) were counted and preliminary correlation tests were performed to see whether the results would be similar. The median was chosen for being more resistant to extreme outliers, and because there were no obvious differences between correlations.

### 3) Teacher-Reported Pupil Concentration

The answers from the day the pupils performed the concentration task were included in these analyses.

### 4) Statistical Analyses

The data were analyzed using the IBM SPSS Statistics tool (version 24). The IEQ and concentration data were

investigated for the four classrooms and the differences between the classrooms were compared using a Kruskal-Wallis test because the data were not normally distributed. The association between the IEQ and pupil concentration data was assessed using Spearman's correlation.

## E. Ethical Considerations

This study was performed in accordance with ethical guidelines and Regulation EU 2016/679 (General Data Protection Regulation). The study for the school environment was reviewed and accepted by the Ethics Committee of VTT. A bulletin on the study with contact details was sent to the pupils' parents via the school's electronic messaging system. The principal presented the study in a parents' meeting. Individual pupils were neither identified nor connected to a specific concentration test in the study. The teachers gave general information about the class (the number of girls and boys and their ages). The participating teachers provided informed written consent.

## III. RESULTS

The data characteristics (see Table III) on the averaged IEQ parameters show that most parameters were close to the recommended target values. In all rooms, the ambient lighting surpassed the targets and even the action limit (limit calling for action when surpassed) occasionally. The relative humidity fell outside the targets occasionally, and the sound levels were always above the targets. In detail, the CO<sub>2</sub> levels slightly surpasses the recommended limits in two classrooms. The recommended target value is 350 ppm, plus outdoor CO<sub>2</sub> (about 430 ppm in Northern Finland) [23], but remained below the action limit (1150 ppm + outdoor CO<sub>2</sub>) in all classrooms [21]. The relative humidity exceeded the target values in all classrooms (target 30-40%) [23], while remaining just below the action limit (>60%) [21]. A low relative humidity is quite typical during the heating season. Additionally, the minimum ambient lighting values were very low, occasionally even surpassing the action limit in all rooms (target >400 lx, action if <200 lx) [23]-[25]. The temperatures were slightly below the recommended target level in one classroom (target 21.5±1.5°C) [23], but still within the action limits (<18 or >26°C) [21]. The sound levels were high in all classrooms with the minimum 47 dB (daytime average target 35 dB), but values were clearly below the action limit (>80 dB) [21]. The IAQ index was high compared to the sensor manufacturer target in all classrooms (target ≤150) [19].

There was a statistically significant difference across all four classrooms in all IEQ parameters except relative humidity and pupil concentration. The selected three IEQ parameters (CO<sub>2</sub>, relative humidity, and temperature) and pupil concentration are shown in Figure 2. The graphs show a slight increase in pupil concentration results throughout the pilot, but no remarkable changes after the change of phase. From the IEQ parameters, the variation is very small in temperature. The relative humidity seems to drop at the end of September to a lower level indicating the start of the heating season. The CO<sub>2</sub> level varied around a similar base level throughout the pilot.

TABLE III. DESCRIPTIVES OF IEQ PARAMETERS AND CONCENTRATION FOR THE CLASSROOMS WITH P-VALUES FROM A KRUSKAL-WALLIS TEST.

	Room 1	Room 2	Room 3	Room 4	P-values
<b>CO<sub>2</sub> (ppm)</b>					
Min	421	429	433	456	
Max	827	797	645	731	
Median	658	600	580	629	0.001
IQR <sup>a</sup>	611-762	529-682	556-599	587-676	
<b>Relative humidity (%)</b>					
Min	20	22	19	20	
Max	58	59	56	59	
Median	32	37	31	32	<b>0.381</b>
IQR	27-37	29-42	26-39	25-42	
<b>Ambient lighting (lx)</b>					
Min	43	52	116	27	
Max	481	264	234	536	
Median	433	124	204	343	<0.001
IQR	107-462	108-243	201-214	198-488	
<b>Temperature (°C)</b>					
Min	20.5	19.5	20.3	20.0	
Max	22.9	22.0	22.1	22.0	
Median	21.8	20.9	21.5	21.2	<0.001
IQR	21.3-22.5	20.4-21.5	21.2-21.8	20.9-21.6	
<b>Sound level (dB)</b>					
Min	47	48	48	53	
Max	66	65	64	74	
Median	56	57	58	63	<0.001
IQR	54-58	53-61	57-60	58-66	
<b>IAQ Index</b>					
Min	48	48	122	54	
Max	230	250	250	250	
Median	175	192	237	226	<0.001
IQR	127-207	147-215	222-244	199-244	
<b>Pupil concentration</b>					
Min	14	12	15	16	
Max	29	24	30	33	
Median	22	19	24	24	<0.001
IQR	19-24	16-21	22-25	21-26	
<b>Teacher-reported pupil concentration</b>					
Min	2	2	2	2	
Max	4	4	4	4	
Median	3	3	3	3	<b>0.077</b>
IQR	3-4	3-4	3-3	3-3	

a. interquartile range

The correlations between the IEQ and pupil concentration are shown per classroom in Table IV. The strongest correlation was found between the relative humidity and pupil concentration with the correlation coefficient  $\rho$  varying from -0.73 to -0.57. This negative correlation indicates an inverse relationship between relative humidity and pupil concentration. This parameter exhibited variation outside the target range. No consistent and strong relationships between other IEQ parameters and pupil concentration were found. However, the following discrete correlations were found: a weak positive correlation with CO<sub>2</sub> in room 1 ( $\rho=0.493$ ,  $P=.012$ ) and room 3 ( $\rho=0.491$ ,  $P=.011$ ), a negative weak correlation with ambient lighting in room 3 ( $\rho=-0.468$ ,  $P=.016$ ), a weak negative correlation with temperature in room 2 ( $\rho=-0.642$ ,  $P=.001$ ), and a moderate (positive) correlation with the sound level in room 2 ( $\rho=0.460$ ,  $P=.014$ ). There was no significant correlation in individual rooms between the measured pupil concentration and teacher-reported pupil concentration.

TABLE IV. SPEARMAN CORRELATION COEFFICIENTS (P) IN RELATION TO THE CONCENTRATION TEST SCORE MEDIAN.

	Room 1	Room 2	Room 3	Room 4
<b>CO<sub>2</sub> (ppm)</b>				
$\rho$	<b>0.493<sup>a</sup></b>	0.274	<b>0.491<sup>a</sup></b>	0.162
Sig. <sup>a</sup> (2-tailed)	0.012	0.185	0.011	0.410
N	25	25	26	28
<b>Relative humidity (%)</b>				
$\rho$	<b>-0.620<sup>**</sup></b>	<b>-0.728<sup>**</sup></b>	<b>-0.568<sup>**</sup></b>	<b>-0.706<sup>**</sup></b>
Sig. (2-tailed)	0.001	P<0.001	0.002	P<0.001
N	25	25	26	28
<b>Ambient lighting (lx)</b>				
$\rho$	-0.335	-0.116	<b>-0.468<sup>*</sup></b>	-0.147
Sig. (2-tailed)	0.101	0.582	0.016	0.454
N	25	25	26	28
<b>Temperature (°C)</b>				
$\rho$	-0.374	<b>-0.642<sup>**</sup></b>	0.082	-0.199
Sig. (2-tailed)	0.065	0.001	0.690	0.311
N	25	25	26	28
<b>Sound level (dB)</b>				
$\rho$	-0.052	<b>0.460<sup>*</sup></b>	0.324	0.103
Sig. (2-tailed)	0.787	0.014	0.092	0.582
N	30	28	28	31
<b>IAQ Index</b>				
$\rho$	0.253	0.223	-0.062	0.215
Sig. (2-tailed)	0.222	0.284	0.763	0.271
N	25	25	26	28
<b>Teacher-reported pupil concentration</b>				
$\rho$	-0.315	-0.182	0.112	-0.197
Sig. (2-tailed)	0.153	0.385	0.603	0.298
N	22	25	24	30

a. Significance

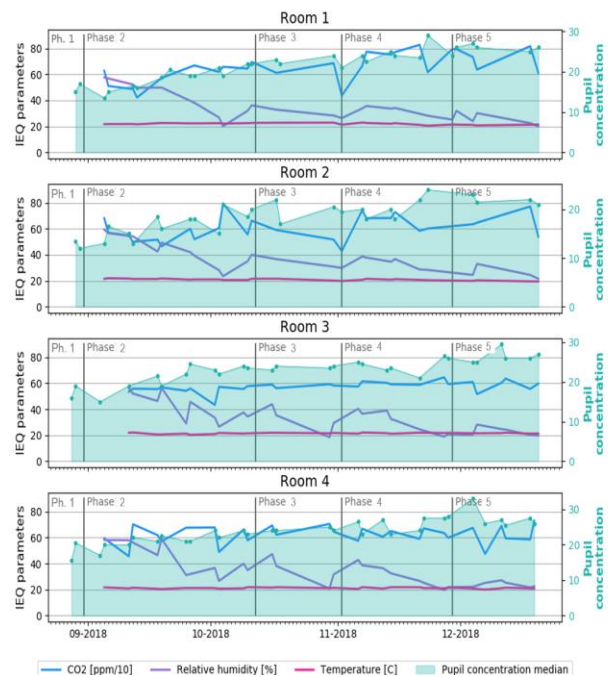

Figure 2. IEQ parameters and pupil concentration median value trends across the study phases.



## IV. DISCUSSION

### A. Reflecting Results

Differing from the majority of the related work, the experiment was conducted over the long-term in a real school environment, and the IEQ parameters were not modified for the study. During the study, the overall IEQ was mainly within approved limits, except for the relative humidity, ambient lighting, and sound levels at times. This makes it difficult to reveal strong correlations between the IEQ and concentration.

Our analysis indicates moderate negative correlation between relative humidity and pupil concentration across all the classrooms. That is, the lower relative humidity, the higher the concentration test score. The relative humidity exhibited variation outside the recommended target range of 30-40% showing a decreasing trend, which was due to the progressive heating of the buildings during the pilot. However, a drop in the relative humidity below the target range did not seem to reduce concentration. There were no clear, strong, and consistent relationships between other IEQ parameters and concentration.

There were slight positive correlations between CO<sub>2</sub> and pupil concentration, being significant in two classrooms. This indicates that a higher CO<sub>2</sub> level was associated with better pupil concentration in those rooms. This is not in line with earlier studies implying that increased CO<sub>2</sub> levels reduce performance [10]-[12]. However, the CO<sub>2</sub> remained generally at good levels in all the classrooms during the study and no clear conclusion can be drawn based on these results.

There were slight negative correlations between the ambient lighting and pupil concentration. This indicates that the higher luminosity is the weaker the pupil concentration. This could be explainable by variation in diurnal daylight and human vigilance variation. In the earlier hours, when the pupils are more alert, there is less natural light in the autumn. Later in the afternoon, the pupils become more tired and their concentration decreases even though there is more natural light. In addition, the location of the sensor was not optimized considering the lighting conditions, which might have caused some degree of error.

There were negative correlations between temperature and pupil concentration in three classrooms, one of which was significant. In general, this indicates that higher temperatures and weaker pupil concentration are associated. This is in line with earlier studies [8]. However, in this pilot, the temperatures rise was moderate and did not rise above 22.9°C in any of the rooms during the pilot period.

There was a significant positive correlation between the sound level and pupil concentration in one room. This means that the more noise there was during the preceding lesson the better the performance the pupils had in the concentration test.

### B. Concentration Task

The paper-format concentration test itself was easy and short to administer. However, the digitization took a long time and was prone to mistakes. In the future, when all the pupils have smartphones or tablets, the test could be performed with a mobile device and the results would be natively in digital form. Electronic test would reduce the chance of mistakes

both in the digitization process and in performing the test. If the test accepts only one correct number at a time, there would be no missing values in the number sequence as it often happened in the paper version. There was a slight learning effect on the pupil concentration throughout the pilot. Even though there was a two-week "training" period before the IEQ sensors were installed, the concentration test results kept improving slightly throughout the 18-week pilot.

Both the pupils and the teachers liked the concentration test. It also benefitted teachers unexpectedly by offering perhaps the only silent moment during class hours in the day.

### C. Limitations of This Study

The sampling rate for the MCF-LW12CO<sub>2</sub> environmental sensor was infrequent, at only every 15 minutes. As a result, a single exceptional value can distort the average in the 45 minutes epoch easily. By averaging the measurements before the concentration test, the longer-term exposure was taken into consideration. However, neither the variation range nor the trend in the IEQ parameters during the 45-minute period were analyzed. It is also uncertain whether the concentration test was performed exactly 45 minutes after a recess. If the first measurement took place during the recess, it would affect the average. Another uncertainty was caused by the MFC sensors' IAQ index, which was based on a proprietary non-open algorithm of the sensor manufacturer and may have  $\pm 15\%$  sensor-to-sensor deviation in values. Although the IAQ index can be mapped to a 7-step classification scale from very polluted to excellent, data interpretation is informal and indicative only without any precise action limits. However, the IAQ index was not shown to be of significant importance in our analyses.

Even though the study was long-term (18 weeks), there were not enough samples to get significant results at these correlation levels. If the correlation was around 0.4 and a power of 0.75, then 26 samples would be enough, corresponding to 13 weeks at the current concentration test rate. However, if the correlation was around 0.3 and a power of 0.75, it would have required approximately 75 samples corresponding to 38 weeks. I.e., it would require collecting data for one whole school year if the tests were administered twice a week. In Northern Europe, changes in meteorological conditions and the building heating season have effects on indoor conditions, which also favors a full-year measurement.

Although, the study could confirm only association between relative humidity and concentration, continuous monitoring of the IEQ is important because it enables the detection of adverse changes in the environment. It can also reveal smaller long-term changes that the humans might not detect as we adapt quickly to the prevailing conditions.

## V. CONCLUSION

This paper presents a study on the associations between objective IEQ data and objective pupil concentration. The study deployed an environmental monitoring system for collecting objective IEQ data using commercial sensors. The system was utilized in a long-term experiment (18 weeks) in a real school environment, where the IEQ parameters were not arranged or modified for study purposes. During the study, the

overall IEQ was mainly within approved limits, except for the relative humidity, ambient lighting, and sound levels at times. The associations between objective IEQ measures and objective pupil concentration were analyzed. A statistically significant inverse association was found between the relative humidity and pupil concentration in all the classrooms. Correlations between other IEQ parameters and pupil concentration could not be confirmed. The performance of the pupils and students in varying IEQ requires further studies. It is recommended to have a longer pilot (e.g., one year), with concentration testing more than twice a week. Despite the challenges in measuring associations between IEQ factors and concentration, it is important to monitor indoor conditions to ensure the well-being of the children. Future work should also study the interaction between concentration, IEQ conditions and, e.g., cognitive factors. Several IEQ factors may cause a significant reduction in perceived work performance indirectly together with individual state factors, including motivation, alertness, focus etc. Thus, the interaction between the individual and indoor environment is a multifaceted topic.

#### ACKNOWLEDGMENT

We would like to thank the pilot participants for their active and significant role in the pilot, and for the school principal, assistant manager, and facility owners for their support which enabled the pilot. Thanks also go to the supporting project team, especially Jari Rehu, Jani Koivusaari and Jussi Ronkainen, for setting up the IoT environment and to Anna-Leena Vuorinen for her statistical consultation. The study was conducted as part of ESTABLISH (Environmental Sensing To Act for a Better quality of Life: Smart Health, ITEA3 project 15008) and SCOTT (Secure Connected Trustable Things, ECSEL Joint Undertaking No 737422 with the support from the EU's Horizon 2020 programme) with the additional national funding from the participating countries and their funding programs. The pilot was designed and implemented with UniqAir, CGI, and InspectorSec.

#### REFERENCES

- [1] E. Csobod et al., "SINPHONIE - Schools Indoor Pollution and Health Observatory Network in Europe - Final Report," Publications Office of the European Union, Luxembourg, 2014. Available at: <https://doi.org/10.2788/99220>.
- [2] Eurostat, Students and Teachers in the EU, 2020, available at: <https://ec.europa.eu/eurostat/en/web/products-eurostat-news/-/DDN-20200604-1> [retrieved: September, 2020].
- [3] Eurostat, "Teachers in the EU", 2019, available at: <https://ec.europa.eu/eurostat/en/web/products-eurostat-news/-/EDN-20191004-1> [retrieved: September, 2020].
- [4] A. Steinemann, P. Wargocki, and B. Rismanchi, "Ten questions concerning green buildings and indoor air quality," *Build. Environ.*, vol. 112, pp. 351–358, 2017.
- [5] M. Kraus, "Airtightness as a key factor of Sick Building Syndrome (SBS)," 16th International Multidisciplinary Scientific GeoConference (SGEM 2016), pp. 439–445, Curran Associates, Inc., 2016.
- [6] W.J. Fisk, "Health and productivity gains from better indoor environments and their relationship with building energy efficiency," *Annu. Rev. Energy Environ.*, vol. 25, pp. 537–566, 2000.
- [7] T. Salthammer et al., "Children's well-being at schools: Impact of climatic conditions and air pollution," *Environ. Int.*, vol. 94, pp. 196–210, 2016.
- [8] P. Wargocki and D.P. Wyon, "Ten questions concerning thermal and indoor air quality effects on the performance of office work and schoolwork," *Build. Environ.*, vol. 112, pp. 359–366, 2017.
- [9] I. Annesi-Maesano et al., "Indoor air quality and sources in schools and related health effects," *J. Toxicol. Environ. Heal. Part B*, vol.16, pp. 491–550, 2013.
- [10] P. Wargocki and D. Wyon, "The effects of moderately raised classroom temperatures and classroom ventilation rate on the performance of schoolwork by children (RP-1257)," *HVAC&R Res.*, vol. 13, pp. 193–220, 2007.
- [11] Z. Bakó-Biró, D.J. Clements-Croome, N. Kochhar, H.B. Awbi, and M.J. Williams, "Ventilation rates in schools and pupils' performance," *Build. Environ.*, vol. 48, pp. 215–223, 2012.
- [12] U. Haverinen-Shaughnessy and R.J. Shaughnessy, "Effects of classroom ventilation rate and temperature on students' test scores," *PLoS One* 10, e0136165, 2015. Available at: <https://doi.org/10.1371/journal.pone.0136165>.
- [13] S. Lamb and K.C.S. Kwok, "A longitudinal investigation of work environment stressors on the performance and wellbeing of office workers," *Appl. Ergon.*, vol. 52, pp. 104–111, 2016.
- [14] G.W. Evans and S.J. Lepore, "Nonauditory effects of noise on children: a critical review," *Child. Environ.*, vol. 10, pp. 31–51, 1993.
- [15] G.W. Evans and R. Stecker, "Motivational consequences of environmental stress," *J. Environ. Psychol.*, vol. 24, pp. 143–165, 2004.
- [16] L.J. Rayneri, B.L. Gerber, and L.P. Wiley, "The relationship between classroom environment and the learning style preferences of gifted middle school students and the impact on levels of performance," *Gift. Child Q.*, vol 50, pp. 104–118, 2006.
- [17] UniqAir Air purifier. Available at: <https://www.uniqair.fi/en/product/uniqair-pro/> [retrieved: September, 2020].
- [18] mcf88. mcf88 MCF-LW12CO2. Available at: <https://www.mcf88.it/prodotto/mcf-lw12co2/> [retrieved: September, 2020].
- [19] Bosch Sensortec. Bosch BME680. Available at: [https://www.bosch-sensortec.com/bst/products/all\\_products/bme680](https://www.bosch-sensortec.com/bst/products/all_products/bme680) [retrieved: September, 2020].
- [20] PeakTech. PeakTech 8005. Available at: <https://www.peaktech.de/productdetail/kategorie/schallpegel-messgeraete/produkt/p-8005.html> [retrieved: September, 2020].
- [21] Finnish Ministry of Social Affairs and Health. Decree of the Ministry of Social Affairs and Health on Health-related Conditions of Housing and Other Residential Buildings and Qualification Requirements for Third-party Experts (545/2015), 2015.
- [22] J. Liukkonen, "Psykykkinen vahvuus-Mielen taitojen harjoituskirja" (Eng. Psychological resilience- Training book for mind). Jyväskylä, Finland: PS-kustannus, 2017.
- [23] Finnish Society of Indoor Air Quality and Climate, "Sisäilmastoluokitus 2018" (Engl. Classification of Indoor Environment 2018 - Target Values, Design Guidance, and Product Requirements), 2018.
- [24] The Finnish Standards Association standard SFS-EN 12464-1.
- [25] "Occupational safety and health administration." Tampere, Finland: Multiprint Oy, 2014.

# Long-Range Data Transmission for Online Water Quality Monitoring of the Tembeling River in Rural Areas of Pahang, Malaysia

Norashikin M. Thamrin

Agrosen Laboratory, Faculty of Electrical Engineering  
Universiti Teknologi MARA  
Shah Alam, Selangor, Malaysia  
e-mail: norashikin@uitm.edu.my

Mohamad Farid bin Misnan

Faculty of Electrical Engineering  
Universiti Teknologi MARA  
Pasir Gudang, Johor, Malaysia  
e-mail: mohamadfarid@uitm.edu.my

Nik Nor Liyana Nik Ibrahim

Department of Chemical and Environmental Engineering  
Universiti Putra Malaysia  
Serdang, Selangor, Malaysia  
e-mail: niknorliyana@upm.edu.my

Navid Shaghaghi

Ethical, Pragmatic, and Intelligent Computing (EPIC) Lab,  
Departments of Mathematics and Computer Science (MCS)  
and Computer Science and Engineering (CSEN)  
Santa Clara University (SCU), Santa Clara, USA  
e-mail: nshaghaghi@scu.edu

**Abstract**— Pahang river’s main tributary, Tembeling river, flows through the Taman Negara national park in Pahang, which is an eco-tourism attraction in Malaysia. Tembeling river is the main sources of water and food for its surrounding communities. However, agricultural and recreational development on the river banks, monsoon season flooding, and maritime activities on the river have polluted the river water to levels that can cause the extinction of fish and thus the loss of the fishermen’s income and livelihood. An automated water quality monitoring system at Tembeling River is therefore believed to benefit the ecosystem immensely. But, the limited mobile network coverage, uneven terrain, and dense forest foliage have made it difficult for wireless data transmission. This paper proposes long-range data transmission via multi-hop short-range Radio Frequency (RF) communication between the remote sensor node(s) and a base station through a network of data extender nodes that utilize the  $\hat{A}B$  network layer Energy Aware Communication Protocol (EACP) in order to take advantage of the nodes’ sleep cycles. Thus, this work hopes to contribute towards providing stable, reliable, and energy efficient wireless data transfer technology for deploying Internet of Things (IoT) solutions in rural areas.

**Keywords**-  $\hat{A}B$ ; Automated Environmental Monitoring; Internet of Things (IoT); Repeater; Tembeling River; XBee.

## I. INTRODUCTION

Malaysia is a country in South East Asia that is bordered by Thailand, Indonesia, Singapore, and Vietnam by sea and land. The country is rich in coastal and mountain diversity and is divided into two sections: Peninsular Malaysia and East Malaysia. Pahang, which is the country’s third-largest state after Sabah and Sarawak in East Malaysia, is the largest state in Peninsular Malaysia. Two-thirds of the state is covered by dense forests, intersected by numerous rivers at its center, joining to form the Pahang river that dominates the drainage system in the region and nourishes Malaysia’s most significant rainforest, namely Taman Negara, which is

estimated to be 130 million years old. Taman Negara is also one of the central regions in Peninsular Malaysia that contributes to the wildlife richness in the country [1]. It has a wide variety of habitat types that host more than 3000 species of plants, 480 species of birds, and 150 species of mammals including some rare species, 30 species of rodents, and more than 80 species of bats [4].

Among the essential ecosystems that are continuously studied in Taman Negara are the freshwater areas [2]-[4] along the Pahang river. The Tembeling river is the main tributary of the Pahang river and a well-known eco-tourism destination for local and international patrons [5][6]. Several major tributaries flow into the Tembeling river, such as Keniam river, Sat river, Sepia river, Tahan river, and Trenggan river. The community utilizes the Tembeling river as a source of water and food. Additionally, places such as the village of Mat Daling (Kampung Mat Daling), Pagi village (Kampung Pagi), Bantal village (Kampung Bantal), and Kuala Sat village (Kampung Kuala Sat) still rely on boats as a means of transportation. Furthermore, a small number of locals perform aquaculture activities in the Tembeling river, where species such as patin (pangasius sutchi) and tilapia are bred [7] for commercial usage.

Unfortunately, extensive anthropogenic activities at the entrance to the Taman Negara including land clearing for the construction of hotels, resorts, and restaurants, improper discharge of wastewater from these amenities, and intense navigation by motor boats, are causing pollution and the destruction of the fish habitat [7][8]. Furthermore, following the monsoon season, a higher concentration of heavy metals such as Silver (Ag) and Cadmium (Cd) are displayed in the river water. The likely source of these minerals is however believed to be from the area’s natural geology [9]. The aforementioned studies suggest that the water supply in the National Park is of acceptable quality for recreational purposes. However, continuous monitoring of

environmental pollutants is essential in keeping the water safe and thus preventing any recreational water illness.

## II. MOTIVATION

An extreme flood in the states of Pahang in 2014 caused massive damage to the region as well as substantial damage to the infrastructure of the cities. Untreated raw sewage entered the Pahang river during the flood which caused the contamination of the water and surrounding environments [10]. As a result, traces of heavy metals were found in the Pahang river fish. Even though the amount discovered was small, it could still be hazardous to human health as measurements have shown that the trace metal concentration in fish samples almost exceeded the recommended levels by the Malaysian Food Act of 1983 [10][11]. The study presented new data from a survey of fish count and their habitat status in Sungai Pahang, specifically located in the Maran district of Pahang. Three groups of fish that were analyzed in the studies indicated that the fish population in this area were influenced by a combination of water quality parameters such as pH and Dissolved Oxygen (DO). The results also provided an important database for future fishing activities and the conservation of fish in the river area [12]. A qualitative study of the settlers living near the Tembeling river was also conducted to observe the vulnerability of the villagers to environmental changes in the river [7]. The study found the problems of the cleanliness of the river, climate change, and the loss of fish and shrimp, have negatively influenced the villagers' daily lives and income.

A continuous water monitoring system at Tembeling and other tributaries of Pahang river to monitor the impact of ecological and anthropogenic activities on fish habitat is therefore important for the future improvement and development of fisheries. The implementation of an IoT monitoring system has many advantages for a variety of purposes and use cases such as measuring environmental radiation, irrigation or harvesting automation, monitoring cattle, ambient temperature sensing, and much more as discussed in numerous work such as [13]-[18]. The architecture for the proposed IoT river water monitoring system consists of three layers, namely, (1) sensing layer, (2) network layer, and (3) application layer. The sensing layer enables water parameters to be identified, sensed, and measured with a variety of sensor devices. In other applications, these devices can be connected through Wi-Fi, Ethernet, serial bus, 3G/4G/LTE/5G, ZigBee, RFID, or other link layer protocols [18]. The primary constraint to this implementation here however is the limitation of the available networks in rural areas such as Tembeling river. In Malaysia, the Ministry of Communications and Multimedia (KKMM) initiated a telecentre system for rural communities to improve their digital literacy through computer and online activities since 2000. The first telecentres constructed were located in Sungai Air Tawar, Selangor and Kota Marud, Sabah. To date, 42 telecentres have been built in

Malaysia. Such telecentres use wireless technology to make it easier for local villagers to access the Internet. In Pahang, there are three telecentres, which were built at Bandar Tun Razak, Bukit Goh, and Sungai Koyan. Sadly, such telecentres are far from the research areas at Kampung Pagi and Tembling river and thus challenging to access. Beyond the challenges of 2G/3G/4G connectivity, another problematic element for wireless data transmission at the remote monitoring site is the uneven terrain that hinders long range Point to Point (P2P) wireless communication by resulting in a Non-Line-Of-Sight (NLOS) link between the transmitter and the receiver.

Previous research typically only investigated the type of fish species, effect on the fish population, and the sociological impact on the Tembeling River community. An IoT implementation to continuously track the river water quality, however, has not been reported so far. Therefore, more work is needed to understand the behavior of communication signals at the remote sites of the Tembeling river.

## III. BACKGROUND AND OVERVIEW

There is a demand for a cost-effective and reliable technique to establish a communication medium in rural areas such as Tembeling river's surrounding areas. To address the problem of limited access to mobile signal coverage (2G/GSM, 3G/WCDMA, 4G/LTE, and 5G) at the Tembeling river's remote site, a P2P system can be used. A seemingly easy P2P solution could involve using LoRa modules operating on frequencies between 919MHz to 923MHz in a similar fashion to existing monitoring systems such as the Hydration Automation (HA) system used for continuous monitoring of water tank levels in farms and ranches [14] or the HiveSpy system used for continuous monitoring of beehive frames for honey production in apiaries [15]. Both of these systems use a network of Relay Units (RUs) - a.k.a. repeaters, for propagating the signal from the Sensing Units (SUs) to the base station over several kilometers.

This paper similarly proposes a procedure for wireless data transmission between the water sensor nodes and the base station by using repeaters. However, due to the fact that the uneven terrain and dense forest in the area inhibit long range P2P communication, a much larger network of more closely positioned repeaters is necessary. Therefore, instead of using the more expensive LoRa modules used in HA and HiveSpy, the usage of cheaper but lower range XBee Pro modules is recommended. XBee Pro modules utilize 2.4Ghz RF serial frequency communication for transmitting and receiving the data. Another advantage of using these modules is that they offer the ability to operate on cheap batteries for years [19].

In order to further prolong the battery life on the modules, sleep cycles will be used. However, as the number of repeaters increase so will the complexity of keeping universal time within the system. A proposed solution is to

readapt the  $\hat{A}B$  networking layer protocol used in the aforementioned monitoring systems [14][15] to work atop of the Zigbee link layer protocol.  $\hat{A}B$  is an Energy Aware Communication Protocol (EACP) used to take maximum advantage of individual node sleep cycles in an IoT system and is agnostic to the physical and medium access layers of the communication subsystem [20]. Therefore,  $\hat{A}B$  provides a great opportunity for the enhancement of the energy efficiency of the water quality monitoring system proposed here for the Tembling river.

Figure 1 shows the proposed remote site for installing an IoT monitoring system of Tembeling river’s water quality in Kampung Pagi. The system’s base station is planned to be located at the local primary school, SK Kampung Pagi, which is about 1.28 kilometers from the remote site. Theoretically, this remote site and the proposed base station can be interconnected with a single hop LoRa solution. However, due to the uneven terrain and existence of a dense rainforest in between the sensors and base station, multiple hops will be necessary. And especially since these hops will not have the possibility to cover grate distances each, the advantage offered by the long range of LoRa modules gives way to the disadvantage of their higher cost in comparison to XBee communication modules. Hence a network of low range yet carefully positioned P2P repeaters that utilizes an energy efficient communication protocol such as  $\hat{A}B$ , presents itself as a realistic solution for this rural area of Tembling river in this remote corner of Malaysia.



Figure 1. The proposed location for testing the long-range data transmission between a sensor node on the bank of the Tembeling River and a base station at Kampung Pagi, in Taman Negara national park in Pahang, Malaysia.

#### IV. LONG-RANGE DATA TRANSMISSION PROTOCOL

The proposed RF long-range data transmission system consists of three parts: (1) sensor node(s), (2) data extender(s), and a (3) base station. Each part is equipped with *XBee Pro* RF transceiver modules. The working range of each *XBee Pro* RF module is estimated at around 3200 meters for line-of-sight (LOS) communication [21], so

theoretically, the values transmitted from the sensor node can be repeated by adding an extender every 3200 meters until reaching the base station. However, because of the uneven terrain and dense forest in Kampung Pagi that limits LOS communication and attenuates the signal strength, the range of the RF signals and thus the number of data extender modules needed will vary. Figure 2 illustrates the overall module structure in the proposed data transmission system.

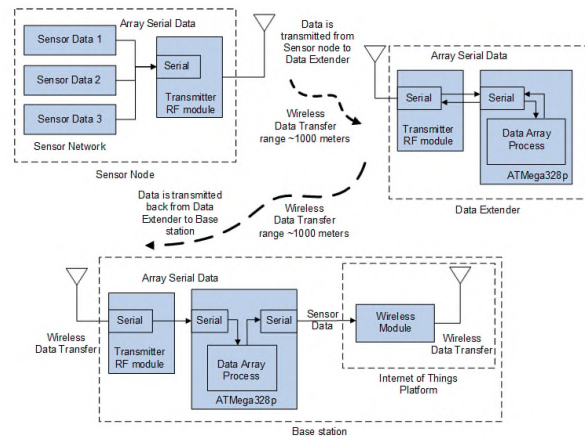

Figure 2. The block diagram of the proposed RF data transmission.

#### A. Sensor Node

The sensor node has several water quality sensors attached, as shown in Figure 3. The data gathered from each of the sensors is collected and appended to an array. The array is then transmitted using the RF transmitter to the next hop in the system which is either the base station itself or a data extender for systems where the sensor node and base station are far apart such as in the proposed system at Tembeling river. Each array packet has a unique identifier in its packet header to identify the sending sensor node so that multiple sensor nodes can be used with a single base station.

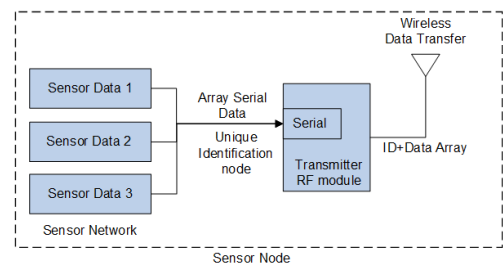

Figure 3. The sensor node to collect water parameters.

#### B. Data Extender

The data obtained from multiple sensor nodes are received and transmitted to another data extender or directly to the base station using RF transceivers. The network of

data extenders is also called a repeater network. Figure 4 shows the innerworkings of a data extender module.

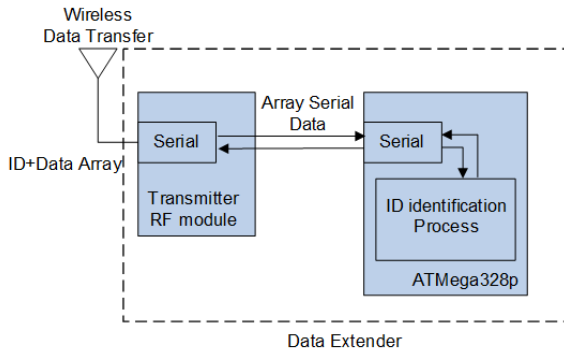

Figure 4. The designed data extender module system.

The data extenders will be placed in appropriate locations between the sensor node(s) and the base station at Kampung Pagi, as shown in Figure 5, which will be determined based on the Receive Signal Strength (RSS) received by the module. The repeaters will be placed at the best places for LOS communication to ensure the reliability in data transmission. However, the terrain and climate will play a major role in the need for specialized or ruggedized extender node casing in order to prevent water from entering the nodes during the monsoon season for instance. Custom ruggedized capsules can however be costly and environmentally un-friendly. Thus, to keep the production cost of the capsules low yet environmentally friendly, they can be 3D-printed using Polyethylene Terephthalate Glycol (PETG) filament which has proven to be resistant to water, prolonged exposure to sunlight, and even acidic conditions [22]. And to ensure the capsules are waterproofed, the same best practices for the 3D-printing of such outdoors capsules as depicted in [23] will be followed.



Figure 5. Possible area for placing Data Extenders in Kampung Pagi.

### C. Base Station

The base station is the part of the system that aggregates all of the data collected by the sensor nodes within an area and relays the data to the World Wide Web. The data gathered from the sensor nodes are transmitted either directly or through data extenders. Thus, the base station must be equipped with the same RF transmitter module as the sensor nodes and data extenders.

As depicted in Figure 6, the received data is filtered and identified based on the unique identification appended in the data array. Then the *ATmega328p* micro-controller, processes the data array by separating it into individual water parameters. The water parameters are then published to the cloud as a JSON payload via an ESP wireless module. The published data are displayed on the online dashboard of the IoT water quality monitoring system in order to enable the remote monitoring of the water quality from anywhere in the world.

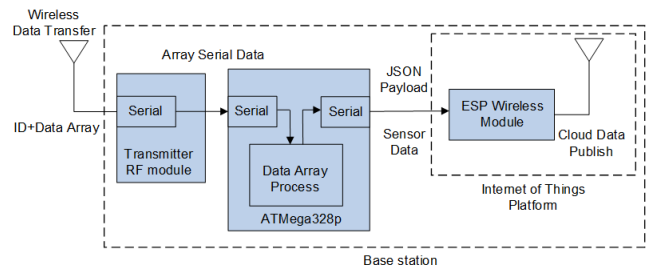

Figure 6. The base station module to transmit the received data onto IoT Cloud platform for online water quality monitoring system.

## V. CONCLUSION

The Tembeling river’s fish habitat are the primary source of food and income for its surrounding communities. Unfortunately, the erratic monsoon season floods, anthropogenic activities in the form of nearby plantation activities and construction for attraction of tourism, and a major increase in maritime commerce and transportation have impaired the water quality and thus endangered many species of fish. For this reason, an IoT monitoring system for water quality is absolutely necessary.

Such a remote monitoring system has to be fitted with long-range wireless data transmission that can visualize the data online. Due to limited mobile network coverage in rural areas as well as uneven terrain and dense forest foliage that inhibits the propagation of long-range P2P communication signals, the data transmitted from the remote sensor nodes must be propagated through the use of a network of short-range RF transmission repeaters that are positioned to maintain LOS communication. The nodes must all be extremely energy efficient and be encapsulated in weatherized casings in order to withstand harsh environmental conditions for long durations. When the data reaches the base station, it is transmitted to a remote server in order to be displayed on a web-based dashboard.

ACKNOWLEDGMENT

This research was made possible with the funding from the Universiti Teknologi MARA (600-RMC/LESTARI SDG-T 5/3(125/2019). Many thanks to the Faculty of Electrical Engineering at Universiti Teknologi MARA for providing facilities and guidance throughout this work. Lastly, the researchers like to acknowledge the department of Chemical and Environmental Engineering at Universiti Putra Malaysia and the departments of Mathematics & Computer Science (MCS) and Computer Science & Engineering (CSEN) at Santa Clara University, Santa Clara, USA for research collaboration.

REFERENCES

- [1] A. Jambari, S. Sasidhran, H. R. A. Halim, K. A. Mohamed, A. Ashton-Butt, A. M. Lechner, and B. Azhar "Quantifying species richness and composition of elusive rainforest mammals in Taman Negara National Park, Peninsular Malaysia," *Global Ecology and Conservation*, 18, 2019, e00607.
- [2] Y. Mohd-Azham and H. R. Singh, "Freshwater fish diversity and their distribution along the Keniyam River, Taman Negara Pahang, Malaysia" In IOP Conference Series: Earth and Environmental Science, IOP Publishing, July 2019, Vol. 269, No. 1, pp. 012034.
- [3] F. A. Farinordin, N. N. Nazri, A. Samat, D. Magintan, A. K. J. P. Besar, M. F. Savuti, and S. M. Nor. "Freshwater fishes of Sungai Sat and Sungai Kelapah. Taman Negara National Park, Pahang". *Journal of Wildlife and Parks*, 2016, 31, pp. 49-60.
- [4] A. M. Radhi, M. F. N. Fazlinda, M. N. A. Amal, and H. Rohasliney. "A review of length-weight relationships of freshwater fishes in Malaysia". *Transylvanian Review of Systematical and Ecological Research*, 2018, 20(1), p. 55-68.
- [5] A. Azlizam, S. N. H. Sved-Alias, J. Mazlina, N. H. Idris, and M. Manohar. "The attractiveness of Taman Negara National Park, Malaysia as perceived by local visitors". *Journal of Wildlife and Parks*, 2018, 33, pp. 1-13.
- [6] A. D. Khairudin and N. H. A. Rahman. "Evaluating the quality experience of ecotourist in Taman Negara Pahang". *E&ES*, 2020, 447(1), 012014.
- [7] S. M. Yassin, A. A. Samah, B. A. Samah, K. Idris, A. Hamzah, and H. A. M. Shaffril. "The sensitivity of communities towards the environmental changes in Tembeling, Pahang and Muar Rivers". *Life Science Journal*, 2013, 10(3), pp. 2143-2152.
- [8] M. S. Adnan, "Development and evaluation of indices to assess the ecological health of the Pahang River", Malaysia. PhD thesis, Kyushu University, 2011.
- [9] S. Rajan, N. N. M. Firdaus, M. Appukutty, and K. Ramasamy. "Effects of climate changes on dissolved heavy metal concentrations among recreational park tributaries in Pahang, Malaysia", 2012.
- [10] N. Manap, K. Sandirasegaran, N. S. Syahrom, and A. Amir. "Analysis of Trace Metal Contamination in Pahang River and Kelantan River, Malaysia". In MATEC Web of Conferences, 2019, Vol. 266, p. 04003. EDP Sciences.
- [11] D. I. Saparuddin. "Determination the concentrations of heavy metals in silver catfish (pangasiusssp.) from Sungai Semantan and Sungai Tembeling", 2017.
- [12] Z. A. Rashid, M. N. A. Amal, and S. Shohaimi. "Water Quality Influences on Fish Occurrences in Sungai Pahang, Maran District, Pahang, Malaysia". *Sains Malaysiana*, 2018, 47(9), pp. 1941-1951.
- [13] A. Tocchi, V. Roca, L. Angrisani, F. Bonavolontà, and R. S. L. Moriello. "First step towards an IoT implementation of a wireless sensors network for environmental radiation monitoring". In 2017 IEEE International Instrumentation and Measurement Technology Conference (I2MTC), May 2017, pp. 1-6.
- [14] N. Shaghaghi, P. Ferguson, J. Mayer, Z. Cameron, and B. Dezfouli, "A Low-power Wireless Sensing Unit for Hydro-System Automation," *2019 IEEE 9th Annual Computing and Communication Workshop and Conference (CCWC)*, Las Vegas, NV, USA, 2019, pp. 0659-0665.
- [15] N. Shaghaghi, HiveSpy. In Proceedings of the 5th EAI International Conference on Smart Objects and Technologies for Social Good (GoodTechs '19). Association for Computing Machinery, New York, NY, USA, 2019, pp. 126–127.
- [16] T. Natori, N. Ariyama, S. Tsuchihara, H. Takemura, and N. Aikawa, "Study of Activity Collecting System for Grazing Cattle". 2019 34th International Technical Conference on Circuits/Systems, Computers and Communications (ITC-CSCC), June 2019, pp. 1-4.
- [17] R. K. Dhammi, K. M. Soni, S. Selvam, and P. Singh. "Real Time monitoring of high temperature of remote places using Wireless Sensor Network without use of any peripheral hardware". *2019 6th International Conference on Signal Processing and Integrated Networks (SPIN)*, March 2019, pp. 850-853.
- [18] S. Guoqiang, C. Yanming, Z. Chao, and Z. Yanxu. "Design and implementation of a smart IoT gateway". In 2013 IEEE International Conference on Green Computing and Communications and IEEE Internet of Things and IEEE Cyber, Physical and Social Computing, August 2013, pp. 720-723.
- [19] M. Orgon, L. Zagaiec, and I. Schmidt. "XBee technology: Complex evaluation of radio parameters". 2019 11th International Congress on Ultra Modern Telecommunications and Control Systems and Workshops (ICUMT), October 2019, pp. 1-6.
- [20] N. Shaghaghi, Z. Cameron, N. Kniveton, J. Mayer, W. Tuttle, and P. Ferguson "AB: An Energy Aware Communications Protocol (EACP) for the Internet of Things (IoT)". 2020 Web, Artificial Intelligence and Network Applications (WAINA) March 2020, Springer Advances in Intelligent Systems and Computing, vol 1150. pp. 877-889.
- [21] Y. Choden, M. Rai, C. Wangchuk, P. Singve, and K. Muramatsu. "Remote Controlled Rescue Robot Using ZigBee Communication". 2019 IEEE 5th International Conference for Convergence in Technology (I2CT), March 2019, pp. 1-5.
- [22] B. Kuhn, "Important Advantages of PETG Filament in 3D Printing". MakeShaper, December 2016. [Online] Available: <https://www.makeshaper.com/2016/11/15/important-advantages-of-petg-filament-in-3d-printing>
- [23] N. Shaghaghi and J. Mayer, "A Sustainable 3D-printed casing for Hydro-System Automation Sensing Units," 2019 IEEE Global Humanitarian Technology Conference (GHTC), Seattle, WA, USA, 2019, pp. 1-7.

# SU 2.0: A Marketable Low-Power Wireless Sensing Unit for Hydration Automation

Navid Shaghaghi, Nicholas Kniveton, Jesse Mayer, Will Tuttle, and Peter Ferguson

Ethical, Pragmatic, and Intelligent Computing (EPIC) Laboratory

Santa Clara University, Santa Clara, California, USA

{nshaghaghi, nkniveton, jdmayer, wtuttle, pferguson}@scu.edu

**Abstract**—The status of crops, water tanks, and various other components of modern agricultural irrigation systems can be sensed and valves and pumps can automatically be actuated to ensure the distribution of adequate water to all parts of the system. In previous work, we have discussed the design and implementation of low cost, small factor, and sustainable Sensing Units (SUs) which use ultrasonic sensors to measure the available empty space in a water tank and communicate the water levels to the Actuating Unit (AU) they are assigned to, so that the AU can operate the valves and/or pumps necessary to send the exact amount of water needed to restore the tanks’ designated water levels. There, we indicated that a future step is the redesign of the circuitry in order to shrink the overall size of the SU, increase its energy efficiency, and enable the addition of new environmental sensors such as temperature sensors that can warn the users or take automated action when the freezing of the water in the tanks is predicted and/or sensed. Also, in previous work we have discussed the design and 3D Printing of a water proofed, cost effective, and environmentally friendly custom encasement for the SUs and indicated that a next step is to redesign the internals of the SU casing in order to allow for the addition of new components while reducing the size of the casing as an effort to reduce the amount of material used and hence enhance the system while further reducing the SUs’ cost. This paper is to report on the success of all these steps and more which collectively enable the production of a marketable smart agricultural environment monitoring SU for irrigation automation.

**Keywords**—3D Printing; Agricultural Internet of Things (IoT); Hydration Automation; Irrigation System; Sensing Units.

## I. INTRODUCTION

Outdoor Internet of Things (IoT) systems such as agricultural automation systems require robust, compact, and reliable nodes combined with algorithms that automate tasks and allow these systems to operate well in the harsh environments they are deployed in. Specifically, irrigation automation equipment such as the Hydration Automation (HA) Sensing Units (SU) [1] is often exposed to environmental elements such as direct sunlight, humidity, extreme temperatures, and temperature fluctuations. To create a viable system, HA combined modular and compact circuitry inside of a custom, 3D printed capsule [2] that wirelessly communicated with the system’s actuators through a robust communication subsystem utilizing a custom in-house routing protocol called ÅB [3], which is specifically developed and fine tuned. The original HA system, and its SUs specifically, proved to be successful. However, the system had room for improvement. By upgrading to more efficient components, creating a compact and modular design, and crafting a custom 3D printed shell, the SU was upgraded into a much more powerful IoT hardware system; and by packaging this

hardware with an advanced software and custom networking protocol, HA was adapted to be a much more capable and widely applicable IoT solution.

The rest of this paper is structured as follows: Section II delineates the hardware changes and circuitry updates in SU 2.0 and Section III details the updates to the system’s communications subsystem. Section IV details the 3D printed casing upgrades and includes waterproofing test results. Section V provides an update on the cost of the units due to the hardware and casing upgrades. Sections VII and VI delineate the work in progress and future steps in the evolution of the SUs, respectively. And finally Section VIII provides some concluding remarks.

## II. HARDWARE CHANGES & IMPROVEMENTS

As with nearly all IoT devices, size, capability, and power are major constraints. The hardware changes made to the SU 2.0 bring the HA system closer to these ideals. These hardware changes included redesigning hardware to be more compact, adding a new sensor to increase capabilities of the SU, and re-configuring the architecture of the system to reduce power usage.

### A. Compact Layout

To accommodate narrow and tight spaces, the SU 2.0 was redesigned using a multi-layer, compact approach that minimizes its mounting surface footprint.

The components of the SU include a Wisen Whisper Node [4] board with an on-board LoRa (Long Range) communication module [5], a JSN-SR04t Ultrasonic Sensor [6], a temperature sensor [7], a voltage regulator, a TP4056 battery charge controller [8], a 5W lithium battery pack, and a 5V 100 mAh solar panel. To design the structure of the unit, the components were divided into three groups:

1. *Components that are not upgradeable by the user and are unlikely to need periodic replacement.* These components include the base PCB (Printed Circuit Board), the charge controller, the step-up voltage regulator, the temperature sensor, and the solar panel connector. All of these have long lifespans which exceed the lifespan of the SU. Hence, these components are all directly soldered to the base PCB board.
2. *Components that do not need periodic replacement, but that the user may wish to upgrade.* These components include the ultrasonic sensor and the Whisper Node micro controller which includes a built-in LoRa communications radio and Real Time Clock (RTC) for



managing the micro controller’s, and as an extension, the entire SU’s sleep cycles.

3. *Components that need periodic replacement.* The only component in this category is the battery, which has a minimum lifespan of 2-3 years.

Grouping the components in this manner allowed the SU 2.0 to be designed using multiple layers, with the non-serviceable components on the bottom and the components requiring periodic replacement on the top.

Since there are no user-replaceable or serviceable components on the charge controller or temperature sensor, they were soldered directly to the prototype board, creating the first layer. The Whisper Node board has software that can be replaced, serviced, or upgraded by the user, but performing this upgrade requires removing the board from the SU housing and connecting it to a computer using a special FTDI enabled USB to TTL Serial adapter. To accommodate software upgrades, the Whisper Node board is mounted on the prototype board using a set of female to male pin headers to allow for easy removal without the need to desolder. The pin headers raise the height of the Whisper Node enough to fit it directly over the battery charge controller and temperature sensor, minimizing space and creating the second layer. The ultrasonic sensor is also mounted on the second layer of the board using a set of female to male pin headers to allow for easy removal and replacement. This allows the user to perform upgrades on the SU 2.0, such as replacing the current sensor with a more powerful sensor or one better suited for liquids other than water.

The first two layers of the unit were then placed into the custom 3D Printed capsule. A 3D printed divider board was then inserted on top of the first two layers of the device and screwed down to the capsule for secure mounting. The battery was then placed on top of this divider board, creating the third and final layer. This separation allows the user to easily replace the battery without risking damage to any of the first or second layer components. The SU is then enclosed by the lid of the 3D printed capsule. The capsule lid includes a solar panel holding bracket which securely mounts a solar panel that provides power to the entire device and recharges the battery during the day. Using this layout, a more compact SU was designed and produced.

**B. Energy Efficiency**

A serious challenge for designing IoT devices is to ensure all components are compatible with each other. One such compatibility issue in the SUs is the operating voltage of the components. Most components in the SU allow for a range of input voltages except for two components which only operate at immutable voltages: the ultrasonic sensor and the battery. The lithium battery used in the SU has a nominal voltage of 3.6 volts, but the ultrasonic sensor only operates at 5 volts, creating a need for a step-up voltage regulator (a.k.a. a boost converter). The usage of the ultrasonic sensor with 3.6v was considered and thoroughly tested. However, it was observed that the range of the ultrasonic sensor was drastically reduced to well below the requirements needed by the system. Therefore in SU 1.0, a boost converter was installed directly after the battery, essentially boosting the battery output voltage to 5v for the entire system. This worked because the Whisper Node’s nominal voltage range is between 3.3v and 5v. However, as

both the documentation of the Whisper Node and energy usage testing by the authors show, the Whisper Node operates less efficiently when it is powered with 5v instead of 3.3v. This, in turn, led to an approximately 15% decrease in overall system efficiency as everything was powered through the boost converter. A 15% loss did not seem significant initially because a more powerful (and hence physically larger) solar panel was installed. This however, became a problem for the SU 2.0 design because the size of the device is reduced dramatically, and thus the original solar panel is bigger than the whole device. This problem was addressed via a specific redesign of the solar panel brackets on top of the casing, as will be discussed in Section IV.

The solution explained above did not however, address the fact that, over time, the 15% increase of energy usage can reduce the battery’s lifespan by hours or even days. To solve this issue, a more compact and efficient step-up voltage regulator is used to feed the ultrasonic sensor alone, rather than the entire SU. Thus, the original voltage booster is eliminated from the design, as can be seen in the SU’s updated circuit diagram depicted in Figure 1.

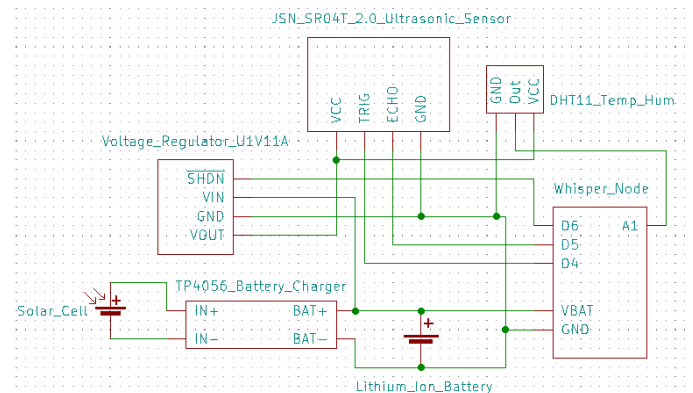

Figure 1. HA SU 2.0 Schematic.

In SU 2.0, the battery is connected directly to the Whisper Node board, which is capable of running at the battery’s nominal 3.6v. This allows for the board to operate without any inefficiencies. For the brief periods of time when the ultrasonic measurements need to be taken, the Whisper Node sets a pin to HIGH, activating the step-up voltage regulator which boosts the voltage provided by the pin to the Ultrasonic Sensor to 5v, allowing a measurement to be taken. After the measurement, the Whisper Node pin is set to LOW, disabling the step-up voltage regulator and thus the ultra sonic sensor in order to conserve power.

Through the changes to the location of components in the SU system, SU 2.0 operates 15% more efficiently than SU 1.0. Thorough before and after testing was performed on the HA power system through multi-week field tests. While the original HA SUs worked well when they had access to sunlight, in situations where the solar panel did not have access to sunlight (due to winter storms, a branch falling on top of panel, etc.) the system would quickly drain in less than a week. Due to the efficiency improvements made, SU 2.0 was able to last well over a week, even with no access to solar power.

### C. Temperature Sensor

The HA system must be usable even when located in environments where frigid temperatures result in the possibility of water tanks freezing. Previously, HA had methods of detecting anomalies, such as alerting a user about the possibility of a leak when it detected an unexpected drop in a tank’s water level reading coming from its SU. This error detection system was reactive and not proactive; meaning it could detect problems such as a tank level dropping after cold temperatures had caused the tank to freeze and burst, but could not predict such failures due to weather related events in advance and enable preventative measures. To enable the SU to predict weather related issues, a HiLetgo DHT11 Temperature and Humidity Sensor module [7] was added to the SUs in order to provide more sensing capabilities regarding weather and climate. By analyzing data from the temperature sensor, the SU’s algorithm can recommend actions to the user in advance. For example, if the SU notices the temperature dropping below a threshold, it can notify the user to drain the tanks to a lower level before the tanks freeze and burst. This can also be automated if actuation capabilities are directly added to each tank’s output valve. However, this is beyond the designed capabilities of a sensing only unit such as the HA system’s current SUs; and thus, beyond the scope of this paper, except for a brief description in Section VII below. Future direct communications between SUs and local tank level AUs, or the addition of such local actuation capability to current SUs is under consideration and research by the HA research and development team.

### III. COMMUNICATION

SU 2.0 uses the custom  $\hat{A}B$  communication protocol [3] to communicate with other nodes in the network, such as Relay Units (RUs) and the base station.  $\hat{A}B$  is a protocol designed from the ground up for IoT devices which takes advantage of the devices’ sleep cycles in order to reduce the overall energy usage of the system as a whole.  $\hat{A}B$ ’s original design is to provide network layer support (a.k.a. routing) to IoT systems that utilize Semtech’s LoRa [9] as their Link layer fOSI model’s combined Data Link and Physical layers) communication protocol. However,  $\hat{A}B$  is built in a modular and medium access independent manner as to allow for its utilization with any existing Link layer protocol. For instance, current efforts are under way by an international team from Santa Clara University’s EPIC laboratory in the United States and researchers from the Universiti Teknologi MARA in Malaysia to utilize  $\hat{A}B$  as the Network layer protocol for a water quality testing system under joint research and development which uses the Zigbee protocol [10] at its Link layer.

### IV. CAPSULE CHANGES & IMPROVEMENTS

The first SU design in [1] utilized an off the shelf IP65 junction box [11], which is shown in Figure 2 on the right. However, this design was not manageable long term as the junction box is created with a very differed purpose in mind. Junction boxes are installed within walls and hence out of the elements for the most part. They have basic weatherproofing to protect against a water leak in the wall, but are not designed to withstand storms, intense daily sunlight, or other environmental abuse present on a farm or ranch. Hence, a

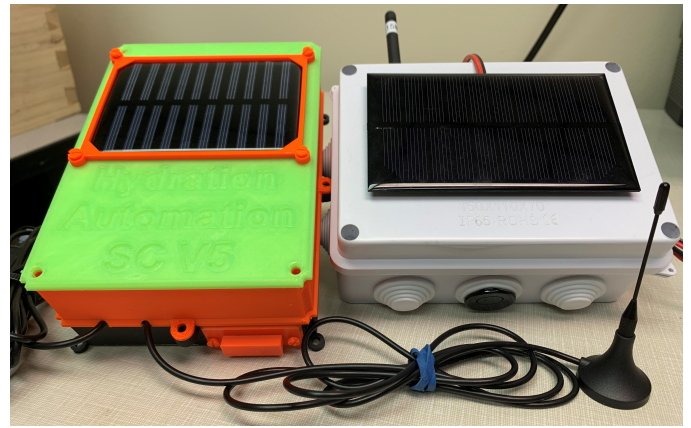

Figure 2. 3D printed capsule on left and original pre-fabricated capsule on right.

custom 3D printed SU casing was developed [2], which is depicted in Figure 2 on the left.

Even though this capsule was far more waterproof, sustainable, and cost effective, it still was very large. As the SU 2.0’s circuitry was shrunk in size, so arose the need to shrink its custom casing. The SU’s latest capsule is thus much smaller and even more waterproof than the previous model. These alterations have majorly simplified the capsule, which has in turn increased the waterproofing and ease of use of the system

#### A. Slide-In Front Wall

In the previous design, the capsule had middle and bottom sections which met at the level of the cables in order to completely seal the entry point and not force the cables to bend. The third generation capsule was designed with a slide in wall depicted in Figure 3a attached to the top section so that the middle section could be removed completely, while still enabling the cables exiting the box to be surrounded all around.

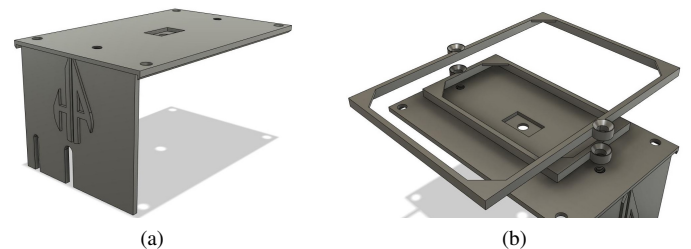

Figure 3. (a) Display of the top section’s slide-in front wall. (b) Solar panel is placed between mounting part and top lid to secure it.

#### B. Solar Panel Mounting

The second generation SU capsule was constrained in its size by the 70 x 100mm solar panel mounted on its lid. In order to reduce the size of the capsule further without changing the solar panels, the mounting system shown in Figure 3b is designed to mount screws along the shortest cross-section of the panel instead of at the corners. This mounting system has

thus enabled the mounting of any solar panel with a cross-sectional size of 70mm or less, as shown in Figure 4. Ideally though, as visible in Figure 4b, the capsule uses smaller 36 x 68mm solar panels akin in size to the panels used in the Relay Unit (RU) capsules delineated in [2].

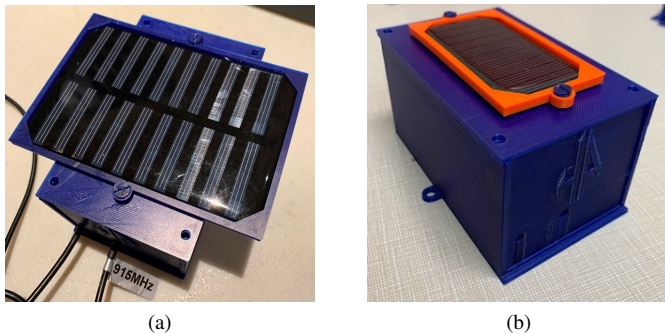

Figure 4. (a) SU enclosure with bigger solar panel mounted. (b) SU enclosure with smaller solar panel mounted.

### C. Battery Separator

The first generation capsule simply housed everything (including the battery) in one compartment [1]. The second generation casing used a 3D printed grid to separate the battery compartment from the circuitry and a custom 3D printed drawer in order to provide easy access for battery replacement [2]. The third generation capsule replaces the mesh and drawer with a specialized battery separator that houses the battery above the hardware, as can be seen in Figure 5. Curved ridges near the edges of the battery separator firmly secure the battery and make it easier for the user as the battery is situated at the top of the capsule and can be easily clicked in and out of its holder once the lid is removed. The battery separator slides into two indents along the side and back walls in order to keep it straight. In addition, a raised screw hole near the front of the capsule enables the locking of the separator in place, which also secures the PCB and hardware beneath it.

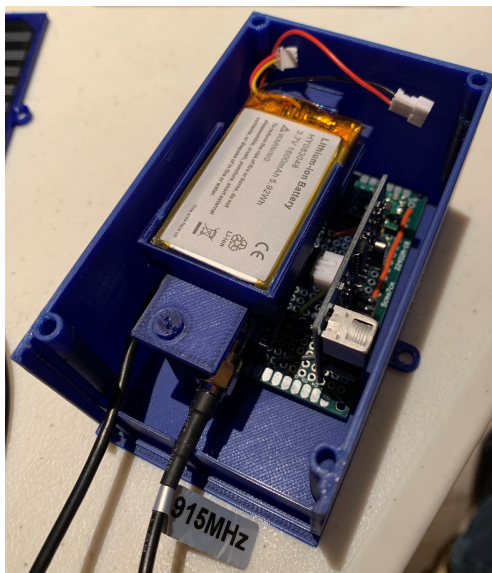

Figure 5. Battery separator situated above circuitry.

### D. Waterproofing

The SU capsules are intended for long-term use outdoors. Thus, ensuring the waterproofing of the system is one of the biggest constraints for the SU’s casing. With this in mind, Polyethylene Terephthalate Glycol (PETG) filament was used in all parts, because it has been proven to be resistant to harsh environmental elements such as rain, prolonged exposure to sunlight, and even acidic conditions [12].

Many of the choices made when designing the third generation SU capsule were in order to maximize its impermeability. Similar to the previous generation of SU capsules, the newest design utilizes exterior overhangs to cover the joints between the top and bottom sections. This ensures that the largest opening in the capsule is more resistant to moisture.

Adding the slide-in front wall, however, required new techniques for waterproofing the opening. Similar overhangs to the ones used on the top were added to the sides and the bottom - where the slide-in wall connects. The cable openings for the cables exiting the unit are thus not located at the bottom of the slide-in wall, but rather designed to meet with the bottom of the capsule at an elevated level so that the cables are surrounded fully on both the top and bottom, as shown in Figure 6. A protective wall was added behind the slide-in wall to ensure an even higher level of protection against any water attempting to enter the unit from the cable opening, as also shown in Figure 6.



Figure 6. (a) A secondary interior wall and external overhangs overlap with attaching sections to prevent water from being introduced. (b) Opening capsule shows moisture behind slide-in wall having been stopped by the protective wall.

### E. Waterproofing Results

When the capsules are used in the real world, they will either be affixed to the top or side of water tanks or placed in a raised position, so they will not be exposed to any puddling. Therefore, when testing the SU capsules in the lab, a mounting frame was designed that holds the capsule vertically off of the ground. In order to simulate the existence of exiting cables from the unit during water testing, 3D printed cable hole stoppers were slid into each of the cable holes, as can be seen in Figure 6b. The capsule was then exposed to a shower of water at varying strengths and for varying duration of time before being inspected for leaks. Figure 7a shows a capsule right after water testing. Upon slowly removing the top section from the bottom, moisture was discovered between the slide-in front wall and the protective wall behind it, as can be seen in Figures 6b and 7b. However, no water was able to enter the capsule or interact with the circuitry, as is also seen in Figure

7b. This proves the accurate functioning of the overhangs and interior protective wall in protecting the circuitry from moisture.

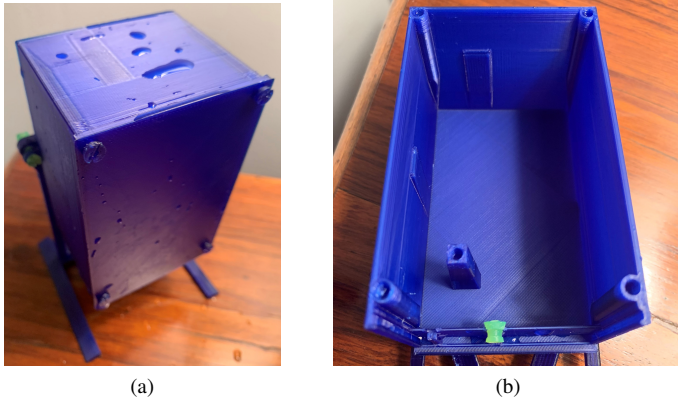

Figure 7. (a) Wet capsule mounted on vertical frame. (b) Interior overview after water testing.

## V. COST ANALYSIS

The cost of developing an SU comes down to the 3D printed casing and hardware (circuitry) used inside.

### A. Hardware

The SU is produced with off the shelf components in order to ensure low cost and ease of repair. This is especially important for systems used in rural areas or developing countries where repair of the system via the replacement of off the shelf components is more feasible than enduring long shipping times at high cost. Table I shows the cost breakdown of each hardware component with the total price of the hardware coming to \$61.98. As the hardware is off the shelf, the prices will fluctuate and thus bring the total price lower or higher at times.

TABLE I. DEVICE HARDWARE COST

Part	Price
Antenna	\$5.35
Battery	\$7.00
PCB	\$0.10
RTC	\$7.63
SMA female edge connector	\$1.22
Solar Panel	\$1.00
Standoff Header Pins	\$0.25
Temp. and Hum. Sensor	\$2.10
Ultrasonic Sensor	\$3.71
Wires and connectors	\$0.50
Whisper Node	\$26.27
Total	\$55.13

### B. Casing

The parts for the third generation SU casing are all printed using Prusament PETG [13], which is manufactured to have a precision of 0.02mm, while most filaments on the market have a precision of 0.05mm. All the capsule’s main sections are printed at a resolution of 0.15mm in order to save time. However, the screws and screw holes are printed at a resolution of 0.05mm, so that their threading will be at the highest quality possible.

As shown in Table II, the cost of manufacturing the capsule is between \$2.27 and \$2.87 depending on whether the vertical mount is included with the capsule or not. This is a massive improvement over the previous capsule’s manufacturing cost of \$9.36, which is 75.75% less. Also, the original ABS (Acrylonitrile butadiene styrene) IP65 junction box [11] used for encasing the circuitry in the very first SU was purchased for \$11.99, with a shipping cost ranging from \$5.98 to \$19.99 depending on the seller. Therefore, even for the lowest shipping cost, 3D printing the latest capsule is 87.37% cheaper than the prefabricated ABS box used in the original SU.

In addition to the direct reduction in manufacturing costs, the reduction in 3D printing time is also significant. The last SU capsule took 34 hours and 19 minutes to print, while the SU 2.0 capsule only takes 10 hours and 27 minutes. This adds up to a 69.55% reduction in print time.

TABLE II. CAPSULE PARTS’ SPECIFICATIONS

Part	Mass (g)	Time (h,m)	Cost (P/A)
Battery Separator	5.87	42m	0.18
Body	45.89	5h, 40m	1.38
FH 5x3.5 m4 Nut (2)	0.16	13m	0.01
FH L8 m4 Screw (7)	0.84	49m	0.03
FH L12 m4 Screw (2)	0.32	18m	0.01
Lid and slid-in wall	19.56	2h, 49m	0.59
Solar Frame (36x68mm)	2.39	19m	0.07
Solar Frame (69x99mm)	3.56	27m	0.11
Vertical Mount	19.55	3h, 54m	0.59
Total with Vert. Mount	95.75	14h, 52m	2.97
Total without Vert. Mount	75.72	10h, 27m	2.38

## VI. WORK IN PROGRESS

### A. Further Casing Upgrades

1) *Magnetic Connectors*: 3D printing small screws is time consuming because they each need to be printed one by one. They are not printed together in order to prevent PETG strings between the screws that result from the hot print head moving from screw to screw as it builds layers onto all of them one by one before moving to the next layer on all of them. Also, the screws do not have a long life expectancy if they are removed and replaced more than several times. This is due to the nature of additive manufacturing and the direction in which the screws need to be built in. Since the screws are 3D printed vertically, their tensile strength is weaker in that direction. As a result, after multiple usages or if they are removed too forcefully, they can snap and thus leave behind multiple layers of their threading within the screw hole. Therefore, to sunset the practice of using 3D printed screws, magnets are being explored for connecting different sections of the capsule. Currently, 4x3mm and 5x1mm magnets are being embedded into the same locations where the screw holes were. This further reduces the print time of the system and eliminates the screw holes on the top section which provides even better waterproofing by limiting the number of possible entry points for moisture even though these screw holes do not lead into the circuitry chamber to begin with.

2) *Addition of Gaskets*: To guarantee waterproofing in situations where the SU may accidentally be submerged by sitting in a puddle or being drooped into the tank during installation or maintenance, gasket material and designs are

under consideration by the research and development team. The gaskets may be 3D printed using Flexible ThermoPlastic Polyurethane (TPU) Filament which is known for its flexibility yet durability and resistance to even oils, greases, and a variety of solvents [14]. These properties make TPU a great candidate for 3D printing gaskets.

### B. Remote bootloader over LoRa

Since the SUs are installed in remote rural locations, it is not the easiest task to manually reset one in case of a software glitch nor to update the firmware on them all when updates are available. Therefore, a remote option for rebooting the micro-controller firmware is essential for agricultural and aquacultural applications to reduce the amount of truck roll necessary. Furthermore, since SUs only contain LoRa connectivity through  $\hat{A}B$ , a custom bootloader over LoRa that utilizes  $\hat{A}B$  packages is needed and thus under development.

### C. WiFi

The SU 2.0 also includes the option to communicate over WiFi using ESP2866 [15] or ESP32 [16] modules. WiFi is used when the SU is close to a WiFi network, such as with a backyard or indoors water storage system. Having the WiFi capability allows for the SU to be more easily integrated into an existing network and negates the need for a base station in a network with only one node.

## VII. FUTURE STEPS

### A. Battery Charge Regulatory Policy

The SU's current design does not include a battery charging regulatory policy and charges the battery to its full capacity. Recent studies have shown that battery lifetime can be extended by avoiding full-battery charge cycles [17]. More testing is still necessary to see how the SU's battery is effected in the long run.

### B. Custom Printed Circuit Board (PCB)

In order to streamline and standardize the production of the SUs, a custom Printed Circuit Board (PCB) is necessary and well overdue. A custom PCB will substantially reduce the points of failure as well as soldering time.

### C. Security

IoT devices are in need of security similar to all other internetworked devices. The security measures must protect the hardware, software, and communication channels.

1) *Physical*: Even though the SUs are not expensive devices, they can still be stolen or vandalized. To prevent the theft of the SU as a whole, it can be secured into place using tamper proof brackets and bolts. To prevent the circuitry from being vandalized or altered, tamper proof bolts and lid opening warning systems in the form of time stamped messages to the base station can be utilized, respectively. Also, tamper proof stickers can be added to the opening of the SU casing so any unauthorized access to the internals of the SU can be detected, at least after the fact.

2) *Software*: The SU tampering detection message to the base station can easily be used as a means for potential software tampering and can thus initiate a backup, bootloading, or even disabling of the node until it is checked and reconfigured. Furthermore, the SU can be programmed to not allow any direct connections, and hence updates, without proper authentication credentials.

3) *Communication*: All SUs must be preregistered with the base station prior to deployment into the field. If an SU is not registered, then its request for assignment to an AU is ignored by the base station; and hence, it will not be included in the RUs' responsibility table, as described in the  $\hat{A}B$  protocol [3]. Furthermore, to protect the base station from being manually jeopardized to allow the malicious node onto the network, the usage of a blockchain for the storage of all registered network nodes is under consideration and research.

### D. Potential Micro-controller changes

The current SU design utilizes a Wisen Whisper Node [4], which includes an on-board LoRa transceiver and an RTC chip. In order to further modularize the system, it would make sense to separate the RTC and communication radio from the microcontroller. This way, any update to the microcontroller would not effect the other components and vice versa. Furthermore, this would enable the easy replacement of the Link layer protocol in the SUs without the need for custom designs for each protocol's radio transceiver. The off the shelf component currently under consideration is the AdaFruit Feather, which comes in many forms such as the Feather M0 Basic Proto [18], Feather M0 adlogger [19], and Feather M0 LoRa [20] if it is decided to always include LoRa capability regardless of other Link protocol additions. A further benefit of the Feather product line is that it has an open source design; and thus, even if Adafruit stops the manufacturing of this product line, compatible replacements will be producible.

### E. Proactive Temperature Sensing

By combining data from the temperature sensor with existing data captured by the system (such as water usage, time of use, solar panel power production, etc.), HA can monitor data trends and take action based on detected changes in order to automatically water crops or disperse water to livestock in the most efficient and effective way possible. For example, if the temperature sensor depicts a sudden drop in temperature for an extended period of time, it can reduce the daily watering rate of the crops, and thus save water. If the opposite occurs, HA can increase the rate of watering to ensure crops are not lost.

HA could also maintain a watering schedule which takes into account the ambient temperature in order to provide more water to livestock during the heat of the day, or to release water for plants during the coolest times of the day to ensure as much of the water is absorbed by the plants as possible and minimize its loss to evaporation. Or, more infrequently, HA could analyze and calculate how much to increase the water flow through the system during a heat wave or how much to reduce it by, when it is raining.

The system needs to be able to make the decisions mentioned above in real time as they can have real world impacts on the crops, livestock, and users. For example, when the software detects a rapid drop in temperature occurring over

an extended period of time, it should open valves at the bottom of the tanks, allowing them to partially drain; as any delay or mistake can result in irreparable damage to the watering system and thus hardships for getting water to crops or livestock; or worse, their loss which will have serious real world consequences for the farmer. This sort of proactive sensing (and actuating) of HA, therefore requires a measure of automated decision making and a robust machine learning mechanism.

### VIII. CONCLUSION

SU 2.0 has improved upon many limitations of the previous iteration such as energy efficiency and size, while offering new features such as improved waterproofing and the addition of temperature sensing. Through reducing the capsule's size, the 3D printing manufacturing time has also been reduced, enabling greater production capacity. The SU improvements reported in this paper have enabled the mass production, real world deployment, and utilization of small form factor, cost effective, and yet sustainable IoT SUs for Hydration Automation systems. Even though many more improvements and additions are under way or slated for future development in Sections VI and VII above, the SU's in their current state are Minimal Viable Products (MVPs) marketable and utilizable in the field today.

### ACKNOWLEDGMENT

Many thanks to Professor Michael McElfresh from the Electrical Engineering Department at Santa Clara University's School of Engineering for his continued support of the project in providing his ranch (Red Thistle Ranch [21]) and water tanks as a test-bed for the Hydration Automation (HA) project. Also thanks to Santa Clara University's Frugal Innovation Hub [22] for their help in seeking out funding for prototyping which was generously obtained from EPICS in IEEE [23], in the form of a starter grant to initiate the project. And thanks to the Ciocca Center for Innovation and Entrepreneurship's Bronco Venture Accelerate (BVA) [24] at Santa Clara University for seeing the potential in the HA system and its assistance in the development of business plans and pitch decks for attracting potential investments that could bring the HA system to the market.

### REFERENCES

- [1] N. Shaghghi, P. Ferguson, J. Mayer, Z. Cameron, and B. Dezfouli, "A low-power wireless sensing unit for hydro-system automation," in 2019 IEEE 9th Annual Computing and Communication Workshop and Conference (CCWC). IEEE, 2019, pp. 0659–0665.
- [2] N. Shaghghi and J. Mayer, "A sustainable 3d-printed casing for hydro-system automation sensing units," in 2019 IEEE Global Humanitarian Technology Conference (GHTC). IEEE, 2019, pp. 1–7.
- [3] N. Shaghghi, Z. Cameron, N. Kniveton, J. Mayer, W. Tuttle, and P. Ferguson, "Ab: An energy aware communications protocol (eacp) for the internet of things (iot)," in Workshops of the International Conference on Advanced Information Networking and Applications. Springer, 2020, pp. 877–889.
- [4] Wisen, "Whisper Node - LoRa," 2018. [Online]. Available: <https://wisen.com.au/store/products/whisper-node-lora>
- [5] Semtech, "SX1276 Transceiver," 2018. [Online]. Available: [https://www.semtech.com/uploads/documents/DS\\_SX1276-7-8-9\\_W\\_APP\\_V5.pdf](https://www.semtech.com/uploads/documents/DS_SX1276-7-8-9_W_APP_V5.pdf)
- [6] Makerguides.com, "JSN-SR04T-2.0 20-600 cm Ultrasonic Waterproof Range Finder," 2018. [Online]. Available: <https://www.makerguides.com/wp-content/uploads/2019/02/JSN-SR04T-Datasheet.pdf>
- [7] Components101, "Dht11—temperature and humidity sensor," 2020. [Online]. Available: <https://components101.com/dht11-temperature-sensor>
- [8] NanJing Top Power ASIC, "TP4056 1A Standalone Linear Li-Ion Battery Charger with Thermal Regulation in SOP-8," 2020.
- [9] Semtech, "SX1276/77/78/79 - 137 MHz to 1020 MHz Low Power Long Range Transceiver," 2015. [Online]. Available: [https://cdn-shop.adafruit.com/product-files/3179/sx1276\\_77\\_78\\_79.pdf](https://cdn-shop.adafruit.com/product-files/3179/sx1276_77_78_79.pdf)
- [10] The Zigbee Alliance, "Zigbee," 2002. [Online]. Available: <https://zigbeealliance.org/solution/zigbee>
- [11] Amazon, "LeMotech ABS Plastic Dustproof Waterproof IP65 Junction Box Universal Electrical Project Enclosure White 5.9" x 4.3" x 2.8"(150mmx110mmx70mm)," 2019. [Online]. Available: <https://www.amazon.com/gp/product/B075DHRJHZ>
- [12] All That 3D, "PET Filament: Waterproof and Food-Safe Material Plastic for 3D Printing," 2019. [Online]. Available: <https://www.allthat3d.com/pet-filament/>
- [13] Prusa Research, "TECHNICAL DATA SHEET Prusament PETG by Prusa Polymers," 2019. [Online]. Available: [https://shop.prusa3d.com/en/index.php?controller=attachmentid\\_attachment=24](https://shop.prusa3d.com/en/index.php?controller=attachmentid_attachment=24)
- [14] MatterHackers, "Flexible Filament," 2019. [Online]. Available: <https://www.matterhackers.com/store/c/flexible-filament>
- [15] Espressif, "ESP8266EX Datasheet," 2020. [Online]. Available: [https://www.espressif.com/sites/default/files/documentation/0a-esp8266ex\\_datasheet\\_en.pdf](https://www.espressif.com/sites/default/files/documentation/0a-esp8266ex_datasheet_en.pdf)
- [16] —, "ESP32 Datasheet," 2020. [Online]. Available: [https://www.espressif.com/sites/default/files/documentation/esp32\\_data\\_sheet\\_en.pdf](https://www.espressif.com/sites/default/files/documentation/esp32_data_sheet_en.pdf)
- [17] V. Agarwal, K. Uthaichana, R. A. DeCarlo, and L. H. Tsoukalas, "Development and validation of a battery model useful for discharging and charging power control and lifetime estimation," IEEE Transactions on Energy Conversion, vol. 25, no. 3, 2010, pp. 821–835.
- [18] Adafruit, "Adafruit Feather M0 Basic Proto," 2020. [Online]. Available: <https://cdn-learn.adafruit.com/downloads/pdf/adafruit-feather-m0-basic-proto.pdf?timestamp=1603664705>
- [19] —, "Adafruit Feather M0 Adalogger," 2020. [Online]. Available: <https://cdn-learn.adafruit.com/downloads/pdf/adafruit-feather-m0-adalogger.pdf?timestamp=1603664717>
- [20] —, "Adafruit Feather M0 Radio with LoRa Radio Module," 2020. [Online]. Available: <https://cdn-learn.adafruit.com/downloads/pdf/adafruit-feather-m0-radio-with-lora-radio-module.pdf?timestamp=1603664735>
- [21] Joanne Weis, "Red Thistle Ranch," 2018. [Online]. Available: [joanneweis.com/2016/02/23/red-thistle-ranch-livermore-ca](http://joanneweis.com/2016/02/23/red-thistle-ranch-livermore-ca)
- [22] Santa Clara University, "Frugal Innovation Hub," 2020. [Online]. Available: <https://www.scu.edu/engineering/labs-research/labs/frugal-innovation-hub>
- [23] IEEE, "EPICS in IEEE," 2019. [Online]. Available: <https://epics.ieee.org>
- [24] Santa Clara University, "Bronco Venture Accelerator (BVA)," 2020. [Online]. Available: <https://www.scu.edu/cioccacenter/bronco-venture-accelerator>