

# Fast Association Scheme over IEEE 802.15.4 based Mobile Sensor Network

Pranesh Sthapit, Yeon-Sang Choi,  
Goo-Rak Kwon, and Jae-Young Pyun  
Department of Information and Communication Engineering  
Chosun University, Korea  
pranesh@chosun.kr, cys@chosun.ac.kr, grkwon@chosun.ac.kr,  
and jypyun@chosun.ac.kr (corresponding author)

Suk-seung Hwang  
Department of Mechatronics Engineering  
Chosun University, Korea  
hwangss@chosun.ac.kr

**Abstract**—IEEE 802.15.4 is designed mainly for static low duty cycle wireless personal area network and its capability to support mobility has not been extensively explored yet. We observed that the amount of time required for the association process is the key reason for making IEEE 802.15.4 unable to handle mobility. In a beacon-enabled network, mobile node can only learn about the existence of any neighbor by listening to incoming beacons. Nevertheless, as neither the channel on which the neighbor operates nor its frequency of beaconing are known, nodes have to scan every available channel, which can take from few to several seconds depending upon the beacon interval. In this paper, we propose a new fast association technique, which prevents nodes from scanning multiple channels. In our proposed scheme, by scanning just a single channel, node can learn about all the coordinators working in different channels. Our single channel scan scheme is able to decrease the association time of IEEE 802.15.4 operation in 2.4 GHz by 32 times. Experiment results have verified that our scheme works well in the mobile environment.

**Keywords**—node association; multi-channel; IEEE 802.15.4

## I. INTRODUCTION

Incorporating mobility in wireless personal area network (WPAN or PAN) is one of the most desirable features today, but it raises many new challenges. WPANs widely use IEEE 802.15.4 due to its low energy consumption, low cost, and small size. In WPAN, node mobility is expected to facilitate numerous applications, from home health-care and medical monitoring to target detection [1]. Wireless body area network (WBAN) is one such area where node mobility is frequent and IEEE 802.15.4 has been proposed as its possible MAC in various literatures [2][3]. There are, however, also multiple other cases in which an IEEE 802.15.4 node needs to discover coordinator in their proximity and establish communication with them. Such a scenario requires very efficient discovery schemata. Although the standard MAC protocol IEEE 802.15.4 has proven to satisfy low data-rate and low power-consumption requirements, the support for mobility is desirable in various WPAN applications [1]. In IEEE 802.15.4, there are mainly two types of devices: full function device (FFD) and reduced function device (RFD). FFD can support all the network functions and can operate as a PAN coordinator or an end device. RFD can only be used as an end device. The IEEE 802.15.4 standard supports three kinds of topology: star, peer-to-peer, and cluster tree topologies, which can operate on beacon and non-beacon-enabled modes.

Node association defines the procedure with which nodes can become a member of WPAN. In beacon-enabled networks, end devices first discover coordinator(s) by listening to the

beacons and then join them by using association messages. However, once a node moves out of the radio range of its parent, it loses synchronization with its parent and finds a new parent.

This paper focuses on the problem of how a node having no initial information about the surrounding can organize fast and energy efficient discovery of other WPANs in a beacon-enabled network. In such case, node can only learn about the existence of any neighbor by listening to their beacons. There are 16 channels in the 2.4 GHz band, 10 in the 915 MHz band, and 1 channel in the 868 MHz band allocated for IEEE 802.15.4 [4]. Nevertheless, as the channel on which the neighbor operates are unknown, nodes have to scan every single available channel in their operational band before getting associated. In this paper, we introduce a novel association scheme called dedicated beacon channel (DBC) in which beacon frame is broadcast in a dedicated channel. Our multichannel solution allows a node to acquire network information about all the coordinators in the vicinity by scanning just a single channel. DBC can decrease the association time of IEEE 802.15.4 by 32 times. However, application of DBC is not limited to IEEE 802.15.4 and can be used in any beacon-enabled network. Furthermore, with the application of DBC scheme, now IEEE 802.15.4 does not require separate channel scans such as ED scan, active scan, passive scan, and orphan scan for learning different status of channels. Our single DBC scheme does functions of all channel scans with minimal time. However, we propose only the modification of association scheme to provide support for mobility where as keeping intact the original features such as flexibility, scalability, adaptability, and low power consumption of original protocol as it is. The proposed scheme is a complete and sophisticated protocol that will be beneficial in the next generation mobile WPAN applications.

The remainder of this paper is organized as follows. Section II presents the brief description on association procedure of beacon-enabled IEEE 802.15.4 followed by related works in Section III. Section IV shows the operation and the main features of the proposed association scheme. The numerical and simulation analysis of the proposed scheme has been described in Sections V and VI. Finally, we conclude the paper in Section VII.

## II. ASSOCIATION IN BEACON-ENABLED IEEE 802.15.4

In the beacon-enabled mode, communication is synchronized and controlled by a network coordinator, which transmits periodic beacons. The beacon contains information related to PAN identification, synchronization, and superframe structure.

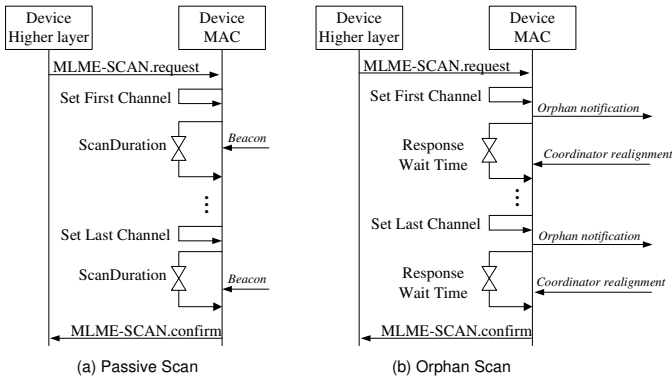

Fig. 1. Channel scanning mechanism in beacon-enabled IEEE 802.15.4.

The superframe may consist of active and inactive periods. The active part of the superframe consists of two groups: the contention access period (CAP) and an optional contention free period (CFP). All communications must take place during the active part, and devices can sleep to conserve energy in the inactive part. The structure of superframe is determined by coordinators using two parameters: superframe order (SO) and beacon order (BO). SO is used to determine the length of superframe duration, while BO defines the beacon interval. The duty cycle of nodes within PAN depends on BO and SO. Increasing both BO and SO, increases transmission latency and decreases system throughput due to intensive channel contention, whereas simultaneously decreasing BO and SO increases energy consumption and reduces available bandwidth [5].

Any FFD could be a PAN coordinator. FFD should perform the energy detection (ED) to detect the peak energy of a channel and choose an appropriate channel for data transmission. In each channel, ED scan is performed for the duration of  $t_{scan}$  symbols. Then, it carries out an active scan to locate any coordinator transmitting beacon frames within its personal operating space (POS). During the active scanning, it first sends out a beacon request command and waits for the duration of  $t_{scan}$  symbols. If a beacon could not be detected in  $t_{scan}$ , the FFD believes that there is no coordinator in its POS and can construct its own PAN by broadcasting its periodic beacons. After a PAN has been initialized, the other devices in the POS of the PAN can communicate with the coordinator and associate with this PAN. In order to start association, an end device needs to know PAN's physical channel, coordinator ID, addressing mode, and PAN ID. In beacon-enabled IEEE 802.15.4, two types of channel scanning operations are performed by end devices. During scan, nodes are deprived from data communication and must discard all data frames received. (i) *Passive scan* is performed by the node, which is just turned on or who failed to find its coordinator through the orphan scan. As shown in Fig. 1(a), during passive scan, a device search for beacon frame in each channel for the duration of  $t_{scan}$  symbols and records the beacon frames received in each channel. If no beacon is detected, the device starts another passive scan after a period of time. (ii) *Orphan scan* allows a device to attempt to relocate its coordinator following a loss of synchronization. The device shall first send the orphan notification command frame, and waits for coordinator realignment command frame for at most  $macResponseWaitTime$  symbols as

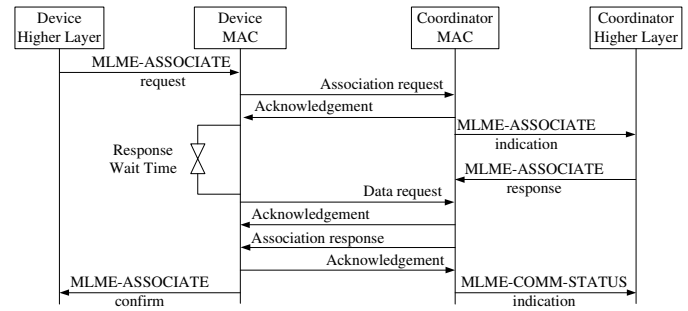

Fig. 2. Association message exchange in IEEE 802.15.4.

shown in Fig. 1(b). This procedure is repeated until it receives the coordinator realignment frame or all the available channels are scanned. If the device is unable to find its parent though the orphan scan, it looks for a new parent by performing passive scan. Once the node finds the suitable coordinator, it can start association procedure by sending a request for association. The message sequence exchanged during the association is shown in Fig. 2. If the association request is permitted, the device will successfully associate with the PAN and get its own PAN address to communicate with others. Thus, in beacon-enabled IEEE 802.15.4, a node association requires channel scanning followed by the association message exchange, which is really a time consuming procedure. For a mobile node, association procedure is even worse because the mobile node has to go through the orphan scan first followed by the passive scan and then only can start the association message exchange. We use the term re-association to explicitly denote the association procedure used by the mobile node. We have observed from our study that if somehow this whole association duration be shortened to some tolerable level, IEEE 802.15.4 can be used in the mobile sensor network applications.

### III. RELATED WORKS

There are some efforts done to minimize the association duration in IEEE 802.15.4. In IEEE 802.15.4e [6], optional fast association (FastA) is defined, which allows a device to associate in a reduced duration. However, most of the efforts are limited to decreasing the duration of association message exchange or coordinator discovery, whereas the channel scanning part has been left untouched. The association duration can be drastically shortened if somehow nodes are prevented from scanning every single available channel. Similarly, there are several works on multichannel solutions, but are limited to throughput improvement or beacon collision avoidance [7][8][9]. To our best knowledge, we are the first to propose the multichannel solution for the association procedure.

In [10], Zhang et al. proposed an improved association scheme called Simple Association Process (SAP) that eliminates the redundant primitives, thus, decrease the packet collisions and the association delay. In order to account for real-time traffic, Meng et al. [11] proposed a new association scheme in which channel scanning is stopped as soon as one of the discovered PAN coordinators is estimated worthy to initiate the association process. Although, this scheme prevents nodes from scanning all available channels, but still nodes need to scan multiple channels before finding the suitable coordinator.

Similarly, there are other works, which focus on the neighbor discovery for quick association. In [12], algorithms

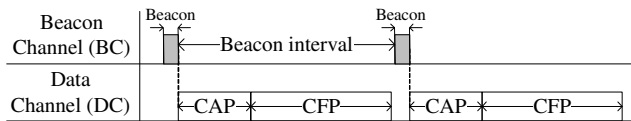

Fig. 3. Channel switching mechanism of the proposed DBC scheme.

are proposed for the optimized discovery of IEEE 802.15.4 static and mobile networks operating in multiple frequency bands and with different beacon intervals. In [13], a scheme to increase coordinator connectivity time with mobile nodes is presented for IEEE 802.15.4 beacon-enabled networks. Nodes use time-stamp of received beacons during the scan, along with link quality to determine the appropriate coordinator for association. Other mobility management schemes for cluster-tree based WPAN have been proposed by Chaabane et al. [14] and Bashir et al. [15]. These approaches use the speculative algorithm for node association based on LQI. Based on LQI value, mobile node anticipates cell change before the loss of connection and tries to associate with the next coordinator. However, in all the cases, nodes have to scan multiple channels to find coordinators.

#### IV. PROPOSED SCHEME

In our proposed DBC scheme, we exploit the channel switching capability of IEEE 802.15.4 radio hardware. In DBC, we proposed the use of two channels: beacon channel (BC) and data channel (DC). BC is used for transmission and reception of the beacon frames only where as the rest of the communication is done in the DC. A fixed dedicated channel is assigned for beacon whereas PAN coordinators are flexible to choose their own DC. Node switches its radio channel to the beacon channel during its beacon period and then returns to its original data channel at the end of the beacon period as shown in Fig. 3. Thus, transmission and reception of the beacon frame is done in the separate beacon channel. With this small and simple modification in the original IEEE 802.15.4, now the nodes do not need to scan each and every channel for the association. The entire network information can be learned by just scanning the BC only as shown in Fig. 4. IEEE 802.15.4 has 4 types of scanning, i.e., ED scan, active scan, orphan scan, and passive scan. Our scheme allows IEEE 802.15.4 to work solely with the single passive scan only. Our scheme has the potential to decrease the association time not just by percentage, but by many folds that we will be demonstrating in coming sections. DBC scheme can be used in any network topology. However, in case of peer-to-peer and cluster tree topologies, we assume that IEEE 802.15.4 successfully avoids beacon collisions.

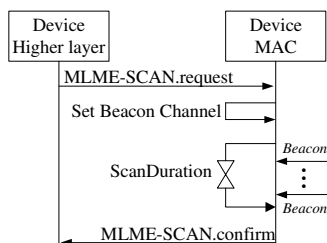

Fig. 4. The passive scan in the proposed DBC scheme.

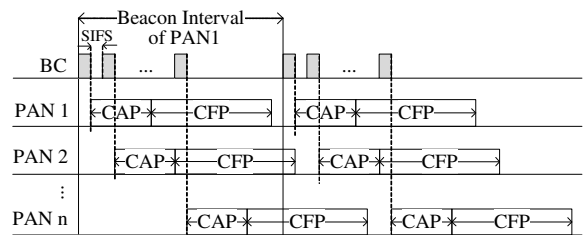

Fig. 5. Co-existence of multiple PANs.

#### A. Modification in Beacon Frame

In order to realize our proposed scheme, the data channel of PAN should be conveyed in the beacon frame. For this, either a new field (data channel of 1 byte) can be added in the beacon frame as shown in Fig. 6 or the data channel information may be piggyback in beacon payload or some other fields.

Frame Control	Sequence Number	Addressing Fields	Auxiliary Security Header	Superframe Specification	GTS Fields	Pending Address Fields	Data Channel	Beacon Payload	FRC
---------------	-----------------	-------------------	---------------------------	--------------------------	------------	------------------------	--------------	----------------	-----

Fig. 6. Addition of data channel field in the beacon frame of IEEE 802.15.4.

#### B. Initialization of a PAN coordinator

Unlike in original IEEE 802.15.4, nodes do not perform ED scan and active scan for initialization of a PAN coordinator. In our proposed scheme, when a FFD is initialized, it performs the passive scan in the beacon channel only for the durations of  $t_{scan}$  (Fig. 4). At the end of the passive scan, the FFD will have the clear picture of all the working PANs in the surrounding and can join the suitable PAN. If a beacon could not be detected in the scan duration, the FFD believes that there is no coordinator in its POS and can construct its own PAN by broadcasting its periodic beacons. The FFD is flexible to select its own non-overlapped DC, but it must broadcast its beacon in the BC. In the case where a number of PANs coexist in an adjacent area, (i.e., apartments or buildings having independent PAN), once the FFD finds out the available PANs through the passive scan, it schedules its beacon period with the minimum gap of the short interframe space (SIFS) than the last beacon frame it received, and chooses the unused DC from the available pool as shown in Fig. 5.

#### C. Association of network devices

A device that wants to associate with a PAN can be a new (just turn on) or an orphan device. In IEEE 802.15.4, there are separate procedures for the association of new and orphan devices. However, in our proposed scheme, there is only the passive scan and both devices perform the same procedure. An unassociated node performs passive scan in the BC for the duration of  $t_{scan}$  symbols. At the end of the passive scan, the end device will have clear information about all the coordinator in the surrounding and may join the suitable coordinator.

#### V. NUMERICAL ANALYSIS

Let  $aBaseSuperFrameDuration$  be the number of symbols forming a superframe when  $SO = 0$  and  $t_{scan}$  symbols be the time spent to scan a channel. In IEEE 802.15.4, it takes equal duration to perform ED, active, and passive scan on a channel and is given by,

$$t_{scan} = aBaseSuperFrameDuration \times (2^{BO} + 1). \quad (1)$$

### A. PAN Initialization

In IEEE 802.15.4, a PAN coordinator performs ED scan and active scan in all available  $n$  channels. But, in case of DBC, only passive scan is performed in the BC for the duration of  $t_{scan}$ . Thus, the total initialization time of a PAN coordinator for IEEE 802.15.4 and DBC is,

$$PAN_{802.15.4\_init} = 2n \times t_{scan}, \quad (2)$$

$$PAN_{DBC\_init} = t_{scan}. \quad (3)$$

Thus, comparing (2) and (3), DBC decreases the initialization of PAN coordinator by the factor of  $2n$ .

### B. Association

The total time spent for association is the sum of time spent in the channel scan and the time spent in the association message exchange ( $Asso_{msg}$ ). A device that wants to associate with a PAN can be a new or orphan. IEEE 802.15.4 has separate procedures for the association of new and orphan devices. The total time spend for association by a newly joining node for both protocols are given by,

$$t_{802.15.4\_asso} = n \times t_{scan} + Asso_{msg}. \quad (4)$$

$$t_{DBC\_asso} = t_{scan} + Asso_{msg}. \quad (5)$$

From (4) and (5), DBC is able to decrease the association time of newly joining node by almost the factor of  $n$ .

In beacon-enabled IEEE 802.15.4, an orphan node performs the orphan scan on each channel for duration of  $macResponseWaitTime$  ( $32 \times aBaseSuperFrameDuration$ ) symbols until its parent is found or all  $n$  channels are scanned. Upon the failure of orphan scan, a new parent is searched through passive scan as mentioned above. Thus, the total time spent for re-association is given by,

$$t_{802.15.4\_reasso} = n \times macResponseWaitTime + t_{802.15.4\_asso}. \quad (6)$$

Thus, comparing (5) and (6), DBC decreases the re-association time of a node by many folds.

### C. Numerical example

Assuming network parameters from Table II, we get  $aBaseSuperFrameDuration$  of 15.36 ms and  $macResponseWaitTime$  and  $Asso_{msg}$  of 0.49 sec [4]. Thus, using these values and above equations and assuming  $BO = 3$ , the association time for both IEEE 802.15.4 and DBC is shown in Table I. From the values obtained in the table, we can conclude that DBC reduces the association time of IEEE 802.15.4 by significant amount and makes association duration independent of the number of available channels. We calculated, theoretically how many times DBC can decrease the PAN initialization and re/association time of the original IEEE 802.15.4 for all values of  $BO$  ( $BO = SO$ ), and the achieved graph is shown in Fig. 7.

TABLE I  
TOTAL TIME SPENT ON ASSOCIATION.

Channels	PAN Initialization		Association		Re-Association	
	802.15.4	DBC	802.15.4	DBC	802.15.4	DBC
3	0.82 s	0.14 s	0.90 s	0.63 s	2.37 s	0.63 s
10	2.76 s	0.14 s	1.87 s	0.63 s	6.77 s	0.63 s
16	4.42 s	0.14 s	2.70 s	0.63 s	10.54 s	0.63 s

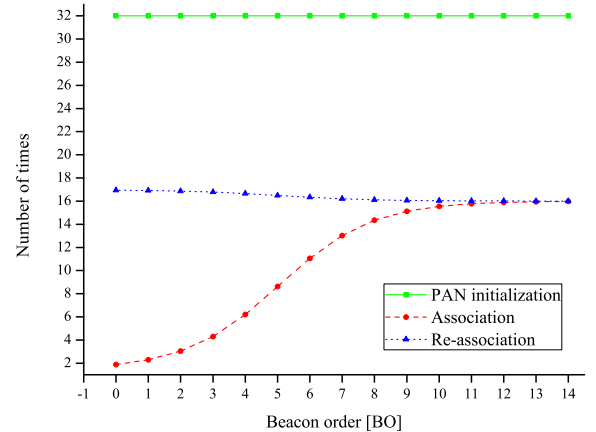

Fig. 7. No. of times DBC improves the association duration of IEEE 802.15.4.

## VI. PERFORMANCE EVALUATION

The simulation analysis is performed using network simulator NS-2. 10 nodes are deployed in a 50x50m field with the PAN coordinator in the center as shown in Fig. 8, where arrow heads indicate the direction of movement of the mobile end device (node 9). All coordinators broadcast beacon, and BO is same for all nodes. In the simulation time of 100 secs, node 9 starts data transmission and at the simulation time of 110 secs, it starts to move. The mobile node continuously moves while transmitting data to PAN coordinator. The simulation ends when the mobile node comes to its original position. There are total 8 cell changes before the mobile node comes to complete rest. In all the simulations, SO is the same as BO. Network parameters are listed in Table II.

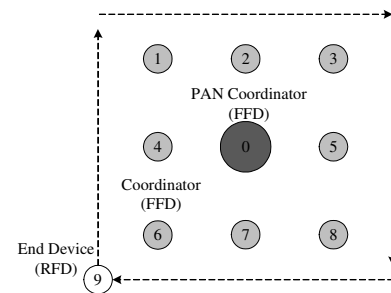

Fig. 8. Network topology used in the simulation.

TABLE II  
NETWORK PARAMETERS AND VALUES.

Parameter	Value
Reception power	56.5 mW
Transmission power	48 mW
Idle power	2.79 mW
Sleep power	30 $\mu$ W
Radio range	10 m
Routing	AODV
Frequency band	2.4 GHz
Radio data rate	250 kbps
Number of Channels	16
Data rate	2 kbps
Traffic	CBR
Buffer size	10 packets
Packet size	50 B

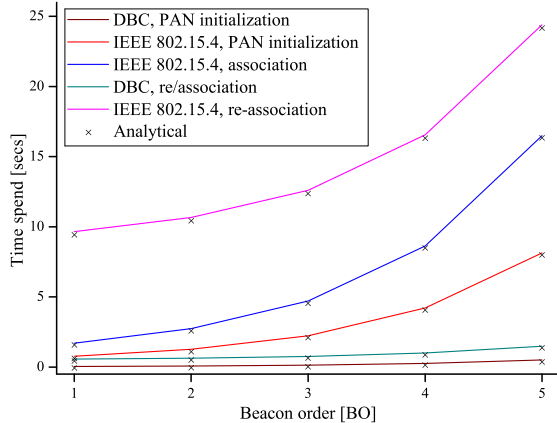

Fig. 9. Total time spent for association at different beacon intervals.

### A. Association Time

Fig. 9 shows the PAN initialization time and the node re/association times for various values of BO obtained from numerical analysis and NS-2 simulations. In the NS-2 implementation, the PAN coordinator performs the passive scan for PAN initialization in the beacon-enabled mode. Similarly, for the assigned BO, except the PAN coordinator, other nodes use  $BO + 1$  internally as the parameter for the scan duration. The numerical equations from Section V were adjusted accordingly. In all cases, the analytical results match well with the simulation results. As shown in the figure, the time required by DBC for re/association is much lower because only the BC is scanned for the association procedure. However, in the case of IEEE 802.15.4, it scans all available 16 channels spending significant amount of time and energy. Also, from the figure, we can see that the time required for both re/association is same for DBC because there is no orphan scan, and the same passive scan procedure is used for both re/association. At  $BO = 3$ , DBC is able to decrease the PAN initialization time by 15.92 times, the node association time by 6.19 times and the re-association time by 16.59 times, which is a great achievement in itself.

The energy spent by the PAN coordinator to start a PAN and for the node re/association under various BO is shown in Fig. 10. Since the time spent by the DBC is much lesser, it has a direct proportional impact in the energy consumption. At  $BO = 3$ , DBC is able to decrease the PAN initialization energy by 7 times, the node association energy by 7.5 times and the re-association energy by 17.75 times. Thus, from above observations, we can conclude that DBC is able to save both energy and time by the significant amount.

### B. Association Success Rate

Success rate of association is calculated as the ratio of successful associations to the total number of possible associations. In our simulation model, there were total 8 associations possible before the mobile node comes to rest. DBC increases the successful association rate of a mobile node by providing quick passive discovery of a coordinator. Percentage of successful associations at different BO(s) and node speeds are shown in Fig. 11. We observed that in case of IEEE 802.15.4, even a slight mobility has a significant negative impact on association. At the human walking speed

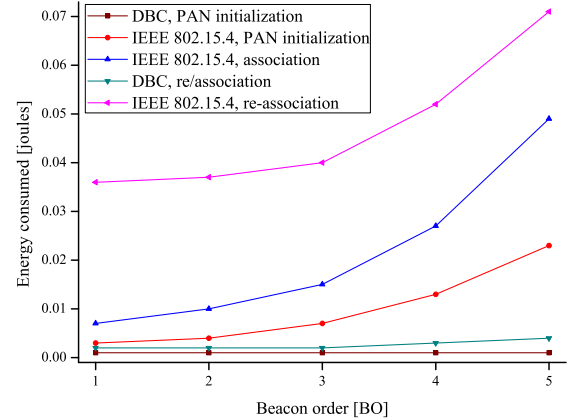

Fig. 10. Energy required for association at different beacon intervals.

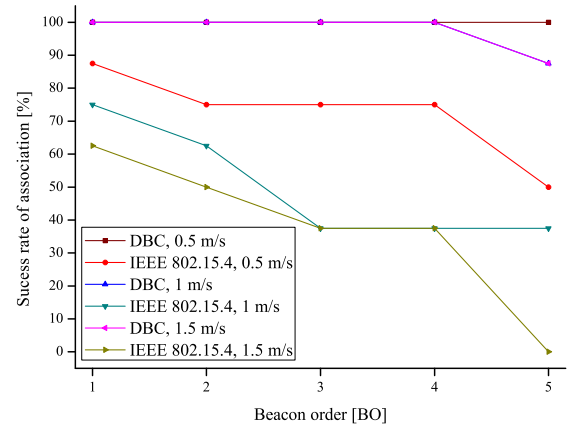

Fig. 11. Association success rate at 0.5, 1, and 1.5 m/s.

of 1.5 m/s, IEEE 802.15.4 has poor success rate of association even at the lower values of BO, and at  $BO = 5$  nodes were completely unable to associate. However, in the case of DBC, association rate was 100% until  $BO = 4$  and even at  $BO = 5$ , DBC could successfully performed 7 associations out of 8. However, at node speed of 1.5 m/s, DBC was completely unable to associate at  $BO \geq 9$ .

### C. Packet delivery ratio and throughput

Fig. 12 shows the throughput observed at the PAN coordinator in packet delivery ratio (PDR). Because of the prompt re/association capability of DBC, mobile node can transmit most of the generated data to the coordinator increasing the overall throughput of the network. We can see in Fig. 12 that PDR of DBC is much better than that of IEEE 802.15.4 for various node speeds, which corresponds to the better throughput achieved. At node speed of 1.5 m/s and  $BO = 5$ , the PDR of IEEE 802.15.4 was just 20% that is also due to the fact that the mobile node 9 gets some opportunity to transmit data through node 6 before it starts to move and cannot associate then after. However, the PDR of DBC was of 82% for the same scenario.

The effect of cell change on throughput observed at the PAN coordinator at the node speed of 1 m/s and at the data rate of 2 Kbps is shown in Fig. 13. Coordinators in the network are using beacon interval corresponding to  $BO = 3$ . The red

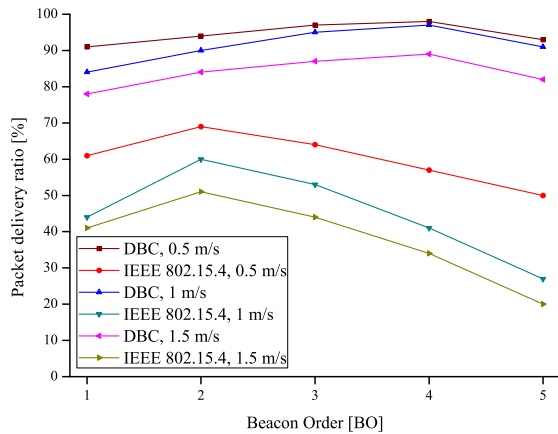

Fig. 12. PDR at different beacon intervals using DBC and IEEE 802.15.4 at 0.5, 1, and 1.5 m/s.

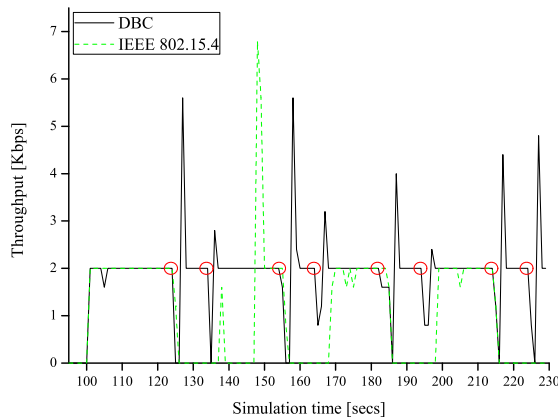

Fig. 13. Throughput observed at BO = 3, mobility of 1 m/s, and data rate of 2 Kbps. Red circle indicates the loss of synchronization by node 9.

circles in the figure indicate the time when the node 9 lost synchronization with the parent coordinator. Throughput of DBC drops while performing cell change because packets can't be transmitted in the periods of passive discovery and association. However, nodes quickly get associated with a new coordinator and restart data transmission. Nodes can buffer packets. Therefore, buffered data are also transmitted after new association is completed, resulting into increased throughput immediately after association. In some cell changes, throughput does not even drop to zero and regains its default value verifying prompt association property of DBC. However, in case of IEEE 802.15.4, nodes were unable to associate in every cell change and out of 8, only 3 successful associations were achieved resulting in poor performance. The PDR observed were of 53% and 96% respectively for IEEE 802.15.4 and DBC.

VII. CONCLUSION

In this paper, we proposed a new association scheme for IEEE 802.15.4 called DBC, which can decrease both time and energy required for association. To achieve the above mentioned advantages, the proposed DBC uses a dedicated channel for beacon transmission, depriving nodes from scanning all the available channels and looking for beacon. Our analytical and simulation results demonstrated that our scheme

is highly efficient in terms of both energy and time. With the implementation of our scheme, we give new direction for IEEE 802.15.4 to be able to handle mobility. However, in this paper we assumed, there is no beacon collision. As future directions, we envision to study and provide solution for beacon-collision avoidance in a dense network.

ACKNOWLEDGMENT

This work was supported by the National Research Foundation of Korea (NRF) grant funded by the Korea government (MEST) (No. 2011-0013062).

REFERENCES

- [1] K. Zen, D. Habibi, A. Rassau, and I. Ahmad, "Performance evaluation of IEEE 802.15.4 for mobile sensor networks," Proc. of the 5th IEEE WOCN '08, India, May 2008, pp. 1-5.
- [2] N. F. Timmons and W. G. Scanlon, "Analysis of the performance of IEEE 802.15.4 for medical sensor body area networking," in Proc. IEEE SECON, Oct. 2004 pp. 16-24.
- [3] N. F. Timmons and W.G. Scanlon, "An adaptive energy efficient MAC protocol for the medical body area networks," in Proc. of IEEE Wireless VITAE, May 2009, pp. 587-593.
- [4] IEEE 802.15.4, "Wireless Medium Access Control (MAC) and Physical Layer (PHY) Specifications for Low-Rate Wireless Personal Area Networks (LR-WPANs)," IEEE, Sept. 2006.
- [5] Y. Huang, A. Pang, and H. Hung, "A Comprehensive Analysis of Low-Power Operation for Beacon-Enabled IEEE 802.15.4 Wireless Networks," IEEE Trans. on Wireless Communications, vol. 8, no. 11, 2009, pp. 5601-5611.
- [6] IEEE P802.15.4e-2012, "Part 15.4: Low-Rate Wireless Personal Area Networks (WPANs), Amendment 1: MAC sub-layer," Feb. 2012.
- [7] F. Osterlind and A. Dunkels, "Approaching the maximum 802.15.4 multi-hop throughput," in Proc. 5th ACM Workshop Embedded Netw. Sens., Charlottesville, VA, Jun. 2008, pp. 1-6.
- [8] E. Toscano and L.L. Bello, "Multiplechannel Superframe Scheduling for IEEE 802.15.4 Industrial Wireless Sensor Networks," IEEE Trans. on Industrial Informatics., vol. 8, no. 2, May 2012, pp. 337-350.
- [9] B.Y. Shih, C.J. Chang, A.W. Chen, and C.Y. Chen, "Enhanced MAC channel selection to improve performance of IEEE 802.15.4," International Journal of Innovative Computing, Information and Control, vol.6, no.12, 2010, pp.5511-5526.
- [10] F. Zhang, F. Wang, B. Dai, and Y. Li, "Performance Evaluation of IEEE 802.15.4 Beacon-enabled Association Process," in Proc. 22nd Int. Conf. Adv. Inf. Netw. Appl., Mar. 2008, pp. 541-546.
- [11] F. Meng and Y. Han, "A New Association Scheme of IEEE 802.15.4 for Real-time Applications," in Proc. Wireless Communications, Networking and Mobile Computing, 2009, pp. 1-5.
- [12] N. Karowski, A.C. Viana, and A. Wolisz, "Optimized Asynchronous Multi-channel Neighbor Discovery," in Proc. Infocom, 2011, pp. 536-540.
- [13] K. Zen, D. Habibi, and I. Ahmad, "Improving Mobile Sensor Connectivity Time in the IEEE 802.15.4 Networks," Proc of Telecommunication Networks and Applications Conference (ATNAC), 2008, pp. 317-320.
- [14] C. Chaabane, C. Pegatoquet, M. Auguin, and M. D. Jemaa, "Energy optimization for mobile nodes in a cluster tree IEEE 802.15.4/ZigBee network," Proc of IEEE Computing, Communications and Applications Conference (ComComAp), 2012, pp. 328-333.
- [15] F. Bashir, W.S. Baek, P. Sthapit, D. Pandey, and J.Y. Pyun, "Coordinator Assisted Passive Discovery for Mobile End Devices in IEEE 802.15.4," in Proc. of IEEE CCNC, Jan. 2013, pp. 601-604.