

Performance Testing of a Low Power Consumption Wireless Sensor Communication System Integrated with an Energy Harvesting Power Source

Vlad Marsic, Alessandro Giuliano, Michele Pozzi, Meiling Zhu and Stewart Williams

School of Applied Sciences
Cranfield University

Cranfield, Bedfordshire, United Kingdom, MK43 0AL

E-mail: v.a.marsic@cranfield.ac.uk, a.giuliano@cranfield.ac.uk, m.pozzi@cranfield.ac.uk,
m.zhu@cranfield.ac.uk and s.williams@cranfield.ac.uk

Abstract— This paper presents the performance testing results of a wireless sensor communication system with low power consumption integrated with a vibration energy harvesting power source. The experiments focus on the system’s capability to perform continuous monitoring and to wirelessly transmit the data acquired from the sensors to a user base station, completely battery-free. Energy harvesting technologies together with system design optimisation for power consumption minimisation ensure the system’s energy autonomous capability demonstrated in this paper by presenting the promising testing results achieved following its integration with Structural Health Monitoring (SHM) and Body Area Network (BAN) applications.

Keywords - vibration scavenging; energy harvesting; low power consumption; wireless sensor communication system;

I. INTRODUCTION

Technological advances have led to increasing levels of automation, but have also contributed to creating new vulnerabilities to equipment failure, human error, weather conditions and other interfering factors. These vulnerabilities need to be addressed using evolutionary approaches. The continuity and viability of critical infrastructures can be ensured using adaptive approaches that monitor sensory data coming from various sensors situated in vulnerable locations. Such networks of sensors that monitor different physical or environmental conditions, and then communicate this data wirelessly to a base station, are known as wireless sensor networks (WSN).

A wireless sensor network consists of sensor nodes that possess computing power and the ability to transmit and receive messages wirelessly. Each sensor node is typically formed of a sensing unit (i.e., sensors), a processing unit (i.e., microcontroller), a transmitter/receiver unit (i.e. the part that connects the node to the network) and an energy source (i.e., a battery or an energy harvester). The energy source is one of the most important components of a sensor node, as this component determines its life span. The use of a battery as energy source would limit the lifetime of the sensor node, and of the entire sensor network. This shortcoming can be addressed by designing self-powered wireless sensor nodes that harvest energy from the surrounding environment and use this energy efficiently to ensure a potentially unlimited

functionality of the sensor node. Energy harvesting from external sources such as ambient vibrations, wind, heat or light could produce sufficient energy for the sensor nodes to be functional indefinitely, as long as the wireless sensor network uses this energy efficiently.

Energy efficiency is a major issue for wireless sensor networks. The most power-consuming activity of a WSN is communication. In our previous work ([1], [2]) this problem was addressed by proposing a novel design and implementation of an autonomous wireless sensor communication system with low energy consumption powered from a vibration piezoelectric harvester. The innovative design and implementation technique targeted power consumption minimisation at three different levels: hardware, software and data transmission, in order to reduce the power consumption of the off-the-shelf components included in the system with the aim of ensuring its energy autonomy through a smart energy flow management. The capability of the resulted system to perform continuous monitoring and to wirelessly transmit the data acquired from the sensors to a user base station was then evaluated in the context of SHM and BAN applications. The main motivation underlying this paper is to present the results of laboratory testing for the designed and implemented low power consumption communication sensing system in SHM and for BAN technology.

This article is structured as follows: Section II reviews previous related work in this field, Section III describes the general structure of our system, while Section IV focuses on its implementation. The testing results collected from the two different setups for SHM and BAN technology are presented in Section V. Conclusions are drawn in Section VI.

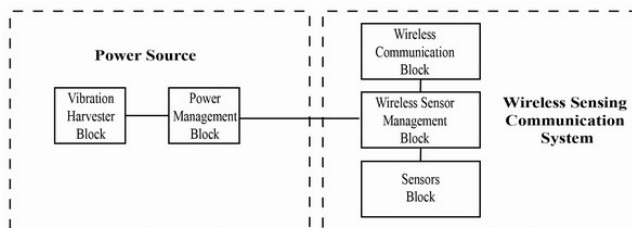

Figure 1. Block diagram of a wireless sensor node powered by a vibration energy harvester

II. STATE OF THE ART

In recent years, energy harvesting devices have attracted much interest due to an increasing need for battery free remote monitoring of different structural parameters. Vibration energy harvesters (EH) can scavenge and transform environmental vibration into electricity using electro-magnetic or piezoelectric structures and, according to their design purpose, one can distinguish two categories: vibration energy harvesters for SHM, and for BAN. The two groups are built differently because of environmental factors such as force, acceleration and displacement, which in the end determine the weight, internal structure, and the impedance of the designed harvester. The devices powered by the above presented groups of EH are used to collect, monitor and display different data directly related to the two domains of BAN and SHM. When powered from a weak power source such as an energy harvester, existing monitoring technology is not suitable to function and provide the full range of monitoring processes such as collecting data, processing and transmitting this information. This is why recent research has focused on the design and implementation of low power wireless communication systems that can be used as autonomous health monitoring systems while being powered only from an energy harvester.

In the case of BAN systems, the vibration harvesting technology was implemented in wrist watches [5], intelligent clothing [6], remote control radio press-buttons [7], [8] and implants [9]. In the case of SHM systems, EH technology was used for monitoring tyre pressure [10], vibrations from vehicles' rotating tyre engines [11], environmental characteristics [12], vibrations from buildings and bridges [13]. Some of these applications feature a low power wireless communication system whose autonomy is ensured through the use of a vibration energy harvester. For example, [11] presented a wireless system powered from a vibration harvester for an aircraft's SHM.

Our previous work [1], [2], focused on the design and implementation of a low power wireless communication system that uses off-the-shelf available technology and is powered from a vibration energy harvester. Laboratory measurements indicated a very good performance and confirmed the advantages of the three level energy consumption optimization approach: the main aim of the design and system implementation methodology was to reduce power consumption at the hardware, software and data transmission levels. The module resulted from our previous research is general enough to be employed in a variety of applications. Its wide generalization capability is demonstrated in the present article, whose novelty lies in the fact that it presents the same low power wireless communication module functioning with the energy produced by a vibrational piezoelectric harvester being successfully employed to provide continuous monitoring in the context of both SHM and BAN applications.

There are no previously published reports of any module relying on vibration energy harvesters capable of continuous self-powering and continuous monitoring both for SHM and BAN, and this is where the present work brings its original contribution.

III. SYSTEM DESCRIPTION

Fig. 1 illustrates a self-powered autonomous wireless sensor system composed of a power source and a wireless sensing communication system. These two main subsystems are further divided into five functional blocks: vibration energy harvester block, power management block, wireless communication block, wireless sensor management block and sensors block.

The vibration energy harvester block is the power supply. The energy it produces is directly dependent on the vibration provided by the wireless sensor deployment environment.

The power management block transforms and stores the energy generated by the vibration harvester.

The wireless sensor management block is the link between the sensors block and the wireless communication block. It takes data from the sensors block and processes it in order to be sent to the wireless communication block.

The sensors block interacts with the external environment and interprets specific stimuli (e.g., temperature, acceleration, light intensity, pressure, etc.) by transforming them in useful signals for the management block processing.

The wireless communication block transmits the data provided by the wireless sensor management block, to a base station which can be linked to the internet or directly to the user.

At the system design stage, the key-problems to be resolved are:

- Reduce the power consumption in the active mode (while executing the programmed instructions, reading sensors' data, and transmitting wirelessly the information), and in the passive mode (while the device is disconnected from the power source or enters an idle mode known as deep sleep, until the energy storage device regains enough energy for the system to function in active mode);
- Preserve the system's basic functionality and compatibility with standards after reducing the energy consumption (i.e., preserve the main function of transmitting data using a certified protocol like IEEE 802.15.4, and respect the restrictions involving power and license for certain geographic regions).

IV. SYSTEM IMPLEMENTATION

This section describes briefly the design and implementation of the system to overcome the challenges that appeared during the initial design stages presented in our previous articles ([1], [2]). The novelty of our approach lies in the analysis and implementation of the optimal strategy to reduce the power consumption for all the embedded off-the-

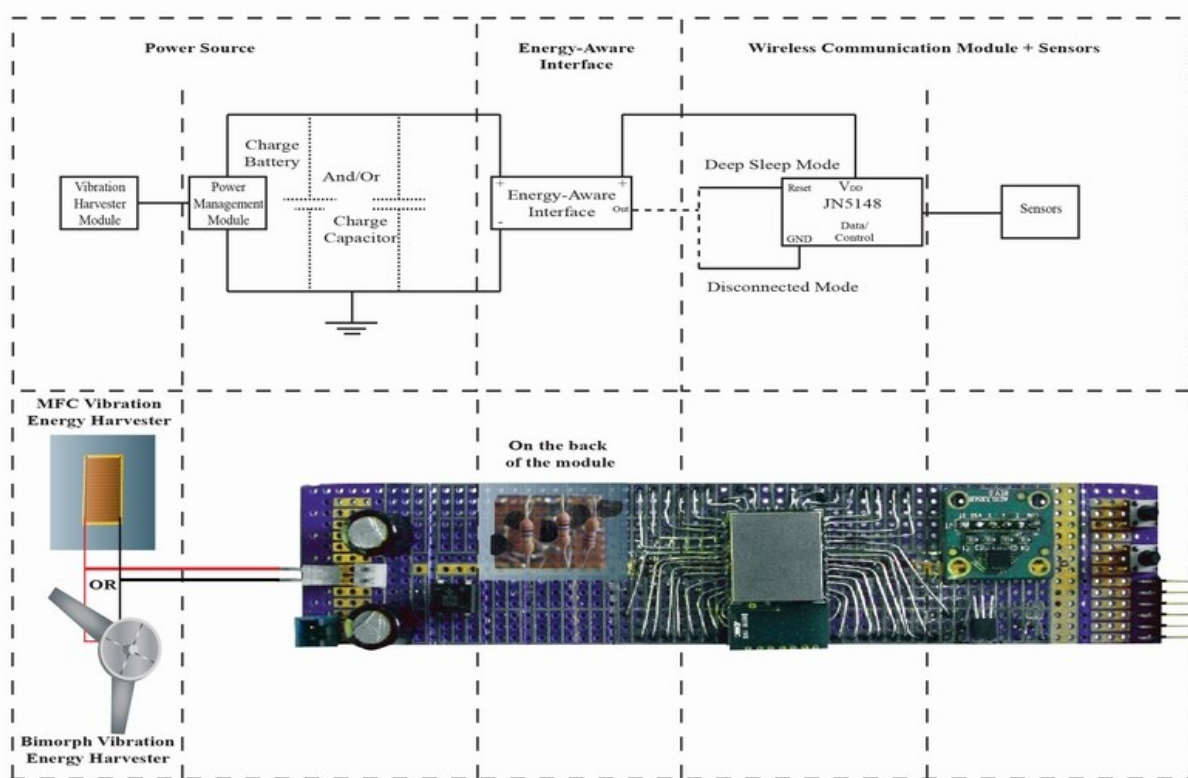

Figure 2. Implemented system architecture.

shelf subsystems at three different levels: hardware, software and data transmission.

At hardware level, the wireless microcontroller was isolated from the power management module during periods of inactivity by introducing an Energy Aware Interface (EAI) which monitored the amount of energy produced by the harvester stored in a charging element, and interrupted the power supply to the wireless communication module until the minimum level of energy required for the active state was reached. The current consumption of the whole system was reduced to 1.19µA for the disconnected mode – the passive mode of the functioning duty-cycle. This represents a 10-times reduction in current consumption before undertaking any modification of the system module.

At software level, the system was improved in terms of reducing power consumption by choosing the most suitable libraries for the application, the right sensors and by designing a suitable power-saving algorithm to read and transmit data.

The choices concerning data transmission were made with a view towards minimising data consumption, preserving the simplicity of the architecture, avoiding collisions and interferences, and ensuring data security. To this end, an IEEE 802.15.4 star configuration was selected for the data transmission level. The data was wirelessly transmitted using 3 different channels corresponding to the 2.4GHz world-wide free license frequency. This

multichannel mode favoured the implementation of a TDMA (Time Division Multiple Access) protocol, thus ensuring better transmission/reception and efficiency due to solving the problem involving the data packets collisions.

The energy harvester is different for each of the applications presented in the following, i.e. SHM and BAN, and it was chosen as the most suitable model for implementation in these two different technologies.

For SHM, the vibration energy harvester is based on the Macro-Fiber Composite (MFC) [14] and glued to an aluminium alloy substrate of the same type used in the airplane industry for producing the aircraft lower wing skin. The aluminium plate is mounted on a tensile testing machine which is used to simulate the airplane wing flying stress levels and vibration conditions.

For BAN, the vibration energy harvester is based on a design created at Cranfield University for a project involving body wearable energy harvesting sources, and described in [15] and [16]. It is composed of four fixed bimorph piezoelectric cantilevers which are fitted in the centre of a wearable rotating wheel. Small plectra are fixed on the interior side of the wheel's outer ring. The wheel is mounted on a stepper motor to simulate the joint-knee movements. When the wheel is rotating, the plectrum pluck the bimorph piezoelectric material, makes it vibrate, therefore converting the leg movement to bimorph vibration, and afterwards to electricity.

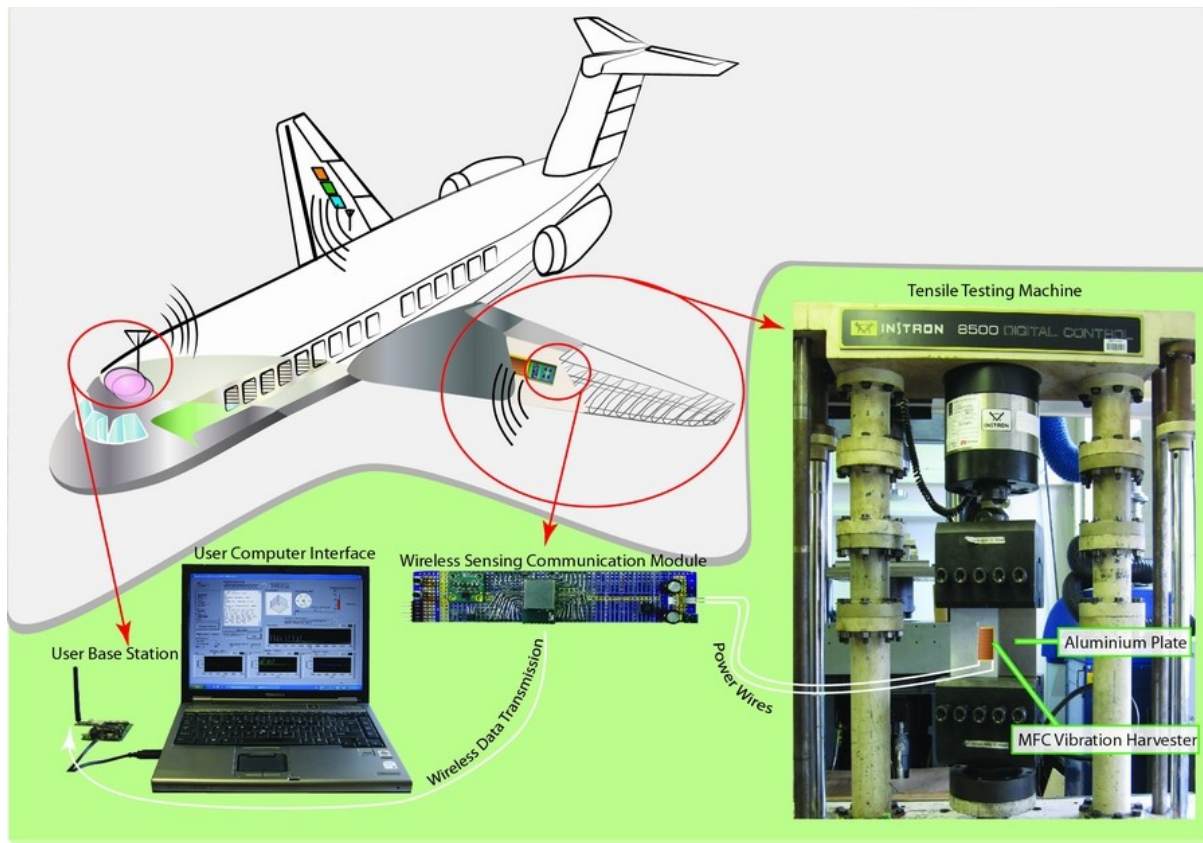

Figure 3. Structural Health Monitoring: application and laboratory testing set-up.

The implemented design of the wireless sensing module powered by a vibration piezoelectric energy harvester is presented in Fig.2. In the context of this architecture, the harvester which converts the vibration energy to electricity, correspondent to the block diagram illustrated in Fig.1 is different for each application: SHM and BAN. The power management module then rectifies the voltage and stores it in two 1mF reservoir capacitors. The energy is discharged when a pre-set threshold is reached. This is triggered by the energy aware interface present on the back of the module. The energy is distributed to each sensor by the wireless microcontroller. The microcontroller, represented by the JN5148 module manufactured by Jennic-NXP is one of the lowest power consumption products currently available on the market. It features a 32 bit CPU (Central Processing Unit), 4 to 32MHz clock frequency and 128Kb RAM (Random Access Memory) [17].

The three sensors were chosen to be included in the system because of their low power consumption, low initialisation time, and also due to the deployed environmental stimuli. The first-one is ADXL 335 3 axes accelerometer [18], the second one is the temperature sensor MCP9700 [19], and the last one is the light intensity sensor GA1A2S100 [20]. All sensors are interrogated by the JN5148 microcontroller, and afterwards the information is

sent to the wireless integrated transmitter/receiver (Tx/Rx). The Tx/Rx is compliant with the IEEE 802.15.4 protocol working at 2.4 GHz frequency and allowing the usage of 16 different channels. Out of those 16 channels, three channels were chosen for a multichannel transmission which allows the implementation of a simple TDMA (Time division multiple access) anti-collision algorithm, reduces the possibility of channel overlapping and interference with the existent wireless applications active in the same area, and also provides the user the possibility to calculate the location of the node using a TOF (Time-of-flight) algorithm. The data is sent wirelessly to the user base station equipped with the same JN5148 wireless microcontroller, powered by a stable power source (battery or DC power source) and linked via a USB cable to a computer. The information is displayed in LabView using a graphical interface especially designed and implemented for this purpose. The signal strength and data from the sensors are monitored and saved for further analysis in two output text files: one containing all the sensors and signal data, and another one counting the number of transmissions/receptions and measuring the time interval between two consecutive ones.

Due to the fact that the module is designed to continuously monitor the vibration, which is its energy source, the system duty cycle is directly related with the

TABLE 1. Experimental Data Transmission for SHM

Test Conditions		Time gap between two consecutive system duty cycle data transmissions [s]				
Frequency	Applied Force (Strain)	11kN (114 $\mu\epsilon$)	21kN (228 $\mu\epsilon$)	31kN (342 $\mu\epsilon$)	41kN (456 $\mu\epsilon$)	51kN (570 $\mu\epsilon$)
	1Hz		39.6	12.5	7	4.9
2.5Hz		13.5	4.9	2.7	2	1.5
5Hz		6.6	2.4	1.5	1	0.8
7.5Hz		6.2	1.7	1.1	0.7	0.6
10Hz		5.2	1.4	0.7	0.6	0.4

energy source: if there is vibration, there is energy to function, to monitor and transmit the data; if there is no vibration, there is no energy and nothing to be monitored.

In order to test the wireless sensing system’s ability to provide continuous monitoring, we powered it, in turn, from two different energy harvesting technologies related to SHM and BAN, the main criterion used to illustrate the performance of the system being the dimension of the time gap between two consecutive duty cycle transmissions.

The data is transmitted with the standard IEEE 802.15.4 speed of 250 kbps, using three different channels, and the total amount of data transmitted during one duty cycle (i.e., data payload, network addresses and correction Bytes) contains 100 Bytes. The system duty-cycle used for testing as presented above and in [2] consists of two stages:

- **Passive mode** – the system is waiting for the energy stored in the 2mF capacitor to reach the preset level in order to start the operations. At this stage, due to the smart management of the energy flow accomplished by the implemented energy aware interface (EAI), the current consumption is 1.19 μ A.
- **Active mode** – the system is reading data from the three sensors and transmits wireless the information to the user base station using a multichannel transmission. The whole process duration is 10ms and the average power consumption to read data and transmit 100 Bytes at +2.5dBm transmission power is 16.7mW.

V. TESTING RESULTS

A. SHM

As previously mentioned in Section III, the wireless sensing system integrated with SHM technology is powered by a vibration harvester based on NASA’s MFC glued on an aluminium plate which is then mounted into the Istron 8500 tensile testing machine. The tensile testing machine is used to apply a range of frequencies from 1 to 10 Hz and a force between 11 and 51kN to the aluminium plate, and the material stress generates a proportional strain, varying from 114 to 570 $\mu\epsilon$.

This investigation is motivated by the intention of implementing piezoelectric vibration harvesters in aircraft wings so that they power wireless sensing systems embedded or mounted in the same area.

The wirelessly transmitted data would be collected by a base station, powered from a regular power source, which can be located inside the airplane body.

The piezoelectric harvesters were chosen against electromagnetic ones due to their light weight, small volume and possibility to be embedded in layered structures or used as patches. The downside of the piezoelectric vibration harvester materials is the small amount of power output and, as a consequence, the power consumption of the wireless sensing system should be reduced at all three levels, hardware, software and data transmission, so that it is able to grant the continuous monitoring capability of the system. The targeted SHM application and the equivalent laboratory testing set-up are presented in Fig.3.

The continuous monitoring capability can be observed in Fig. 4 obtained by plotting the data stored by the LabView user interface. The data reveals a gap of only 0.4s between two consecutive data transmissions for 10Hz vibration frequency and 51kN (570 $\mu\epsilon$) of applied force.

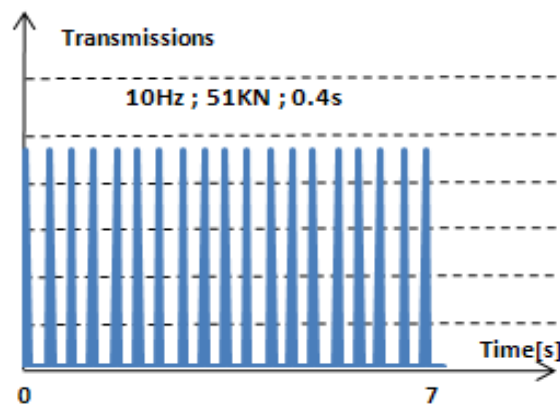

Figure 4. Time gap between transmissions for SHM.

The measured time gap between two consecutive system transmissions (duty cycle) is presented in Table 1, for all frequencies and strain outputs generated when the applied force is present. As results included in the table above demonstrate, the system’s continuous monitoring capability is achieved not only for higher vibration frequencies like 7.5-10Hz, when it can monitor and transmit new data every 0.4s, but even at a vibration level of 1Hz, when it can transmit the 100 Bytes of information every 3.5s.

B. BAN

In the case of the BAN technology, the power is supplied by the wearable “Pizzicato energy harvester”, [21], [22], developed at Cranfield University.

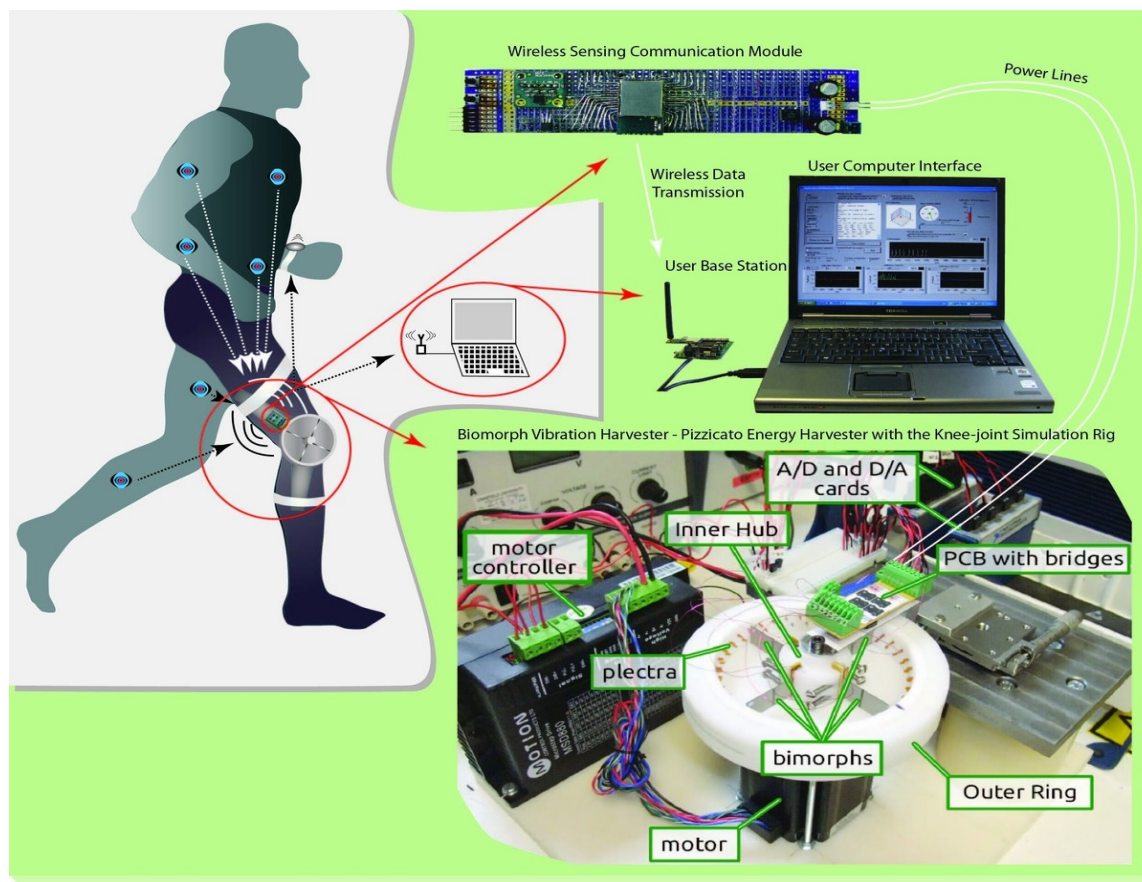

Figure 5. Body Area Network: application and laboratory testing set-up.

This system is designed to be fitted externally on the side of a human knee in order to produce energy by harvesting the body movement. For the tests presented in this paper, the harvester was fitted onto a stepper motor controlled via a controller driver interface and a National Instruments data acquisition card (DAQ).

The aim of the application is to monitor and to wirelessly transmit real time data about the bearer, using the three sensors already described, and/or to link future implantable sensors with shorter wireless range, interrogating them and retransmitting the data to the user base station which can be a regular computer or a wearable low power consumption display interface (i.e., wrist watch), as in Fig. 5.

Three simulated testing scenarios were used for the harvester movement based on real data gathered from human behaviour monitoring. The first scenario simulates the movements of a human carrying an empty backpack, the second one simulates a human carrying 12kg inside the backpack, and the third one a human that has 24kg inside the backpack. The power from the piezoelectric harvester, after rectification, is transferred via two wires to the wireless sensing module. The module stores the energy in the 2mF capacitors and transfers it to sensors and microcontroller when there is enough to perform the duty cycle. Afterwards,

it transmits the 100 Bytes to the user base station for further analysis.

A representative example of continuous monitoring capability can be observed in Fig. 6. The data shows a gap of only 1.1s between any two consecutive data transmissions for the simulated scenario when the backpack contains 0kg of weight.

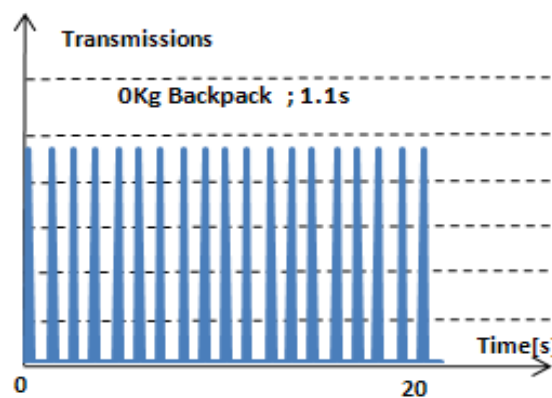

Figure 6. Time gap between transmissions for BAN.

The experimental test results obtained for the all three tests described above are presented in Table 2.

TABLE 2. Experimental Data Transmission BAN.

Simulated Situations	Time gap between two consecutive system duty cycle data transmissions [s]
0 kg Backpack	1.1
12 kg Backpack	1.1
24 kg Backpack	1.1

The results of these experiments demonstrate the system’s continuous monitoring capability for BAN energy harvesting technology, being able to transmit the 100 Bytes of data every 1.1s for all the three simulated scenarios.

VI. CONCLUSIONS

This work relies on a low power consumption wireless sensor communication system that was designed and implemented so that the power consumption was minimised at three levels: hardware, software and data transmission. This optimisation strategy that guided the system development was directed towards the aim of achieving energy autonomy, while at the same time ensuring the required functionality only with the power provided by a low power vibration energy harvester. The resulted battery-free wireless sensor communication system built using only off-the-shelf components, and powered by a low energy vibration harvester, was employed in two different applications: SHM and BAN monitoring. The successful testing scenarios presented in this paper illustrate the system’s ability to not only adapt for usage with two different energy harvesting technologies, but also to continue monitoring and to transmit wirelessly via multichannel the 100 Bytes of information, using a standard communication protocol and the transmitter power pre-set at the highest level of +2.5dBm at the same time achieving a speed between two transmission duty cycles of 0.4s for SHM and 1.1s for BAN.

Further directions of research will focus on each deployment environment scenario, and will investigate ways to decrease the power consumption either by replacing the set of general purpose sensors with one dedicated sensor, or by using a different transmission frequency or different transmission protocols, or by optimising other application-specific factors.

REFERENCES

[1] Marsic V., Zhu M., and Williams S., “Design and implementation of a wireless sensor communication system with low power consumption for energy harvesting technology”, Proceedings of the 19th Telecommunications Forum TELFOR 2011, pp. 607 – 610, 2011.
 [2] Marsic V., Zhu M., and Williams S., “Wireless sensor communication system with low power consumption for integration with energy harvesting technology”, TELFOR Journal, Volume 4, 2012.

[3] Lee T.H., “The design of CMOS radio-frequency integrated circuits a nonlinear history of radio”, A Nonlinear History of Radio, Cambridge University, pp. 1-34, 1998.
 [4] Theremin L. S., “Signaling apparatus”, U.S. 1658953, Feb 14, 1928.
 [5] Paradiso J. and Starner T., “Energy scavenging for mobile and wireless electronics”, IEEE Pervasive Computing, 4(1), pp. 18-27, 2005.
 [6] Hum A., “Fabric area network – a new wireless communications infrastructure to enable ubiquitous networking and sensing on intelligent clothing”, Computer Networks, 35(4), pp. 391-399, 2001.
 [7] Paradiso J. and Feldmeier M., “A Compact , Wireless , Self-Powered Pushbutton Controller Design”, pp. 299-304, 2001.
 [8] EnOcean, “PTM 100 User Manual”, http://docweb.khk.be/khk/remote/technologie/EnOcean/MAN_ENG1.pdf [Accessed 01 Feb. 2012].
 [9] Platt S., Farrant S., Garvin K., and Haider H., ”The use of piezoelectric ceramics for electric power generation within orthopedic implants”, Mechatronics, IEEE/ASME Transactions, 10(4), pp. 455-461, 2005.
 [10] Daniel S., “Piezoelectric reed power supply for use in abnormal tire condition warning systems”, U.S., 4510484, Apr 9, 1985.
 [11] Arms S., Galbreath J., Townsend C., Churchill D., Corneau B., Ketcham R., and Phan N., “Energy Harvesting Wireless Sensors and Networked Timing Synchronization for Aircraft Structural Health Monitoring”, Proceedings of the 1st International Conference on Wireless Communication, Vehicular Technology, Information Theory and Aerospace & Electronic Systems Technology, pp.16-20, 2009.
 [12] Del Balzo D., Chen H., Hughes B., Cranford C., and Stewart S., “Drag body design in support of wave energy harvesting”, OCEANS 2010, pp.1-6, 2010.
 [13] Galchev T., McCullagh, J., Peterson R.L., and Najafi, K., “Harvesting traffic-induced bridge vibrations”, Proceedings of the 16th International Solid-State Sensors, Actuators and Microsystems Conference (TRANSDUCERS), pp. 1661 – 1664, 2011.
 [14] High J. W. and Wilkie W. K., “Method of Fabricating NASA-Standard Macro-Fiber Composite Piezoelectric Actuators”, Technology, pp. 1-30, 2003.
 [15] Pozzi M. and Zhu M., “Characterization of a rotary piezoelectric energy harvester based on plucking excitation for knee-joint wearable applications”, Smart Materials and Structures, 21(5), 2012.
 [16] Pozzi M., “Analytical Modelling of a Plucked Piezoelectric Bimorph for Energy Harvesting”, arXiv.org Physics, arXiv:1204.0070, 2012.
 [17] Jennic-NXP, ”JN5148-001 Data Sheet”, http://www.jennic.com/files/product_briefs/JN-DS-JN5148-1v6.pdf [Accessed 01 Feb. 2012].
 [18] Analog Devices, “Small, Low Power, 3-Axis ±3 g Accelerometer ADXL335”, <http://www.sparkfun.com/datasheets/Components/SMD/adxl335.pdf> [Accessed 01 Feb. 2012].
 [19] Microchip, “MCP9700/9700A MCP9701/9701A, Low-Power Linear Active Thermistor™ ICs”, <http://www1.microchip.com/downloads/en/DeviceDoc/21942e.pdf> [Accessed 01 Feb. 2012].
 [20] Sharp, “GA1A2S100SS/GA1A2S100LY OPIC™ Linear Output Ambient Light Sensor”, http://sharp-world.com/products/device/lineup/data/pdf/datasheet/ga1a2s100ss_ly_e.pdf [Accessed 01 Feb. 2012].
 [21] Pozzi M. and Zhu M., “Plucked piezoelectric bimorphs for knee-joint energy harvesting: modelling and experimental validation”, Smart Materials and Structures, 20(5), 2011.
 [22] Pozzi M. and Zhu M., “Pizzicato excitation for wearable energy harvesters”, SPIE Newsroom, SPIE10.1117/2.1201104.003682, 2011.