

Intelligent Wireless Body Area Network System for Human Motion Analysis

Per Anders Rickard Hellstrom, Lennie Carlén Eriksson, Jonatan Scharff Willners,
Mia Folke and Martin Ekström

Embedded Sensor Systems for Health (ESS-H)
Mälardalen University, Innovation, Design and Engineering (IDT)
Västerås, Sweden
email: per.hellstrom@mdh.se

Abstract— Human motion analysis provides several important applications. Examples are fall risk assessment, sports biomechanics, physical activity monitoring and rehabilitation. This work in progress paper proposes an intelligent wireless body area network system for motion and gait symmetry analysis. A Bluetooth network with accelerometers, gyroscopes and in-shoe force sensing resistors gathers data and sends it to a web server after intelligent pre-processing and filtering. The system is flexible and adaptable for different use cases including combinations of gait analysis, gait symmetry and pressure measurements between foot and shoe.

Keywords— motion analysis; wireless; body area network; Bluetooth Low Energy.

I. INTRODUCTION

Analysis of human motion provides several important applications. One example is fall risk assessment in the ageing population. Falling accidents are common and the frequency increases with age and often result in injury or even death [1]. The falls are also a cost for the individual as well as for the society. Other motion analysis applications are rehabilitation [2][3], sports activity monitoring [4] and evaluation of the amount of physical activity in daily life [5]. Gait symmetry analysis is an important form of motion analysis [6].

Portable motion analysis can be done in several ways and some of the more popular choices of sensors include accelerometers, gyroscopes and in-shoe force sensing resistors. A combination of these approaches would give a more complete motion analysis.

Pedobarography, the study of pressure fields acting between the plantar surface of the foot and a supporting surface, have been used in gait and posture analysis [7] but also in prosthetics evaluation [8] and sports biomechanics[9]. Accelerometers are common for monitoring physical activity and can measure the position and motion of the body together with gyroscopes [10].

The two most popular pedobarography measurement systems that offers telemetry options are Novel's Pedar. (Novel GmbH, Munich, Germany) with capacitive sensors and Tekscan's F-Scan (Tekscan Inc., Boston, MA, USA) with resistive sensors.

These systems cost over €13000 for the wireless versions. F-scan measures up to 0.86MPa and is 0.15mm thick. Pedar measures up to 1.2MPa and is 1.9mm thick.

A commercial system with inertial measurement units is SHIMMER3 (Shimmer, Dublin, Ireland). It is equipped with a MSP430 (Texas Instruments Inc., Dallas, TX, USA) microcontroller unit and uses Bluetooth 2.0 to communicate with other units.

This paper describes a wireless system for motion, gait and symmetry analysis. A body area network with accelerometers, gyroscopes and in-shoe force sensors is proposed. The amount of sensors is decided by each application. Bluetooth low energy chips are used for the local data communication. Data can be stored locally in a data sink until communication with a web server is available. Calculations and analysis with low computational burden will be done in the sensor nodes and in the data sink to save bandwidth.

The proposed system is described in Section II, with four subsections for (A) hardware, (B) data communication, (C) analysis and (D) initial measurements. Discussion will be in Section III.

II. SYSTEM DESCRIPTION

A wireless body sensor network with up to seven motion processing units, eight force sensing resistors and two temperature sensors is proposed. A data sink is used for temporary local data storage and uses mobile telecommunication or Wi-Fi to connect to a web server.

A comparison of the proposed system and other similar systems are shown in Table 1. The other systems are called Physilog 4 Silver (Gait Up A.S., Lausanne, Switzerland) [11], GaitShoe [12] and SmartStep [13].

A. Hardware

Bluetooth Smart modules BLE113 (Bluegiga Technologies Ltd., Espoo, Finland) provides wireless communication between up to seven sensor nodes and the data sink. BLE113 has an 8051 microcontroller and an 8 channels 12-bit analog-to-digital converter (ADC) at 4kHz for connecting external sensors such as the force sensing resistors.

Table 1. COMPARISON BETWEEN THE PROPOSED SYSTEM AND SIMILAR SYSTEMS

Name	Node dimensions [mm]	Node weight [grams]	Sensor types and analog-to-digital resolution [bit]	Data communication	Sampling frequency [Hz]	Battery life time [hours]
Proposed system	41x34x15	Slightly over 20g	3D accelerometer (16-bit) 3D gyroscope (16-bit) 3D magnetometer (13-bit) Force sensing resistors (12-bit)	Bluetooth Low Energy ver. 4.0, 3G/4G or Wi-Fi to send data to server	At least 1kHz is possible, 30Hz currently until programming is improved	Weeks without the force sensing resistors, otherwise at least 24 hours
Physilog 4 Silver (Gait Up, newer version than in the article) [11]	50x37x9.2	19g	3D accelerometer (16-bit) 3D gyroscope (16-bit) 3D magnetometer (13-bit) Barometer	RF node sync., local data storage, cable to transfer data to computer	Up to 500 Hz	Up to 21 hours
GaitShoe [12]	25x44x17	Less than 22g	3D accelerometer 3D gyroscope Force sensing resistors Electrical field sensor Bend sensor (12-bit)	RF	75Hz	6 hours
SmartStep [13]	Not known, node located on back of shoe	Total system weight is less than 35g	3D accelerometer Force sensing resistors (12-bit)	RF	25Hz	20 hours

Each sensor node has a 9 degrees of freedom motion processing unit MPU-9150 (InvenSense Inc., Sunnyvale, CA, USA). It has a 3-axis 16-bit accelerometer up to 1kHz, a 3-axis 16-bit gyroscope up to 8kHz and a 3-axis 13-bit magnetometer. The electronics are powered by a 240mAh lithium-ion polymer (LiPo) battery. A sensor node under construction is seen in Figure 1. Time between charging is in the order of weeks if no external sensors are used and if there is not a lot of retransmission of data due to an extremely harsh environment.

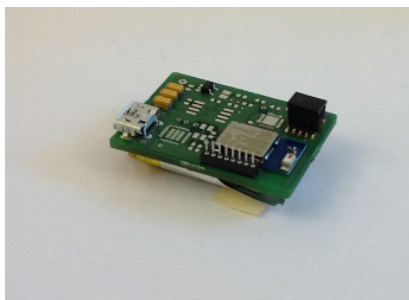

Figure 1. Sensor node prototype under construction.

Custom printed circuit boards host the following: the BLE113, motion processing unit MPU-9150, battery charging circuit with micro USB connection, JTAG interface for programming and headers for attaching an adapter card on top of the board. The block diagram of a sensor node is seen in Figure 2.

The adapter card is used with the two sensor nodes which include the force sensing resistors and temperature sensors. Amplifying circuits for these sensors are also placed on the adapter card.

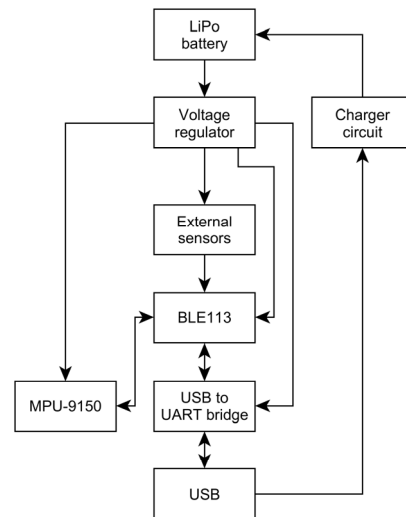

Figure 2. Sensor node block diagram.

The force sensing resistor ESS301 (Tekscan Inc., Boston, MA, USA) has a round sensing area with a diameter of 9.5mm and is 0.20mm thick. It can withstand 95% humidity and this is important because the sensors will be placed inside shoes. The temperature sensors are only used for compensation of the signal drift of the force sensing resistors due to changes in temperature. Four force sensing resistors will be used in each shoe positioned at heel (A), outer (B) and inner (C) side of the metatarsal pad and big toe (D). See Figure 3 for anatomical sensor locations. The temperature sensor goes under the foot valve and all these sensors are attached to the shoe insole which is placed inside the shoe. The discrete sensor

locations are common choices decided by the bones in the foot [8][14][15].



Figure 3. A is heel, B and C are on metatarsal pad and D is big toe pad.

The chest and three nodes for each leg (at the hip, just above the knee and on top of the shoe) are the seven locations for the sensor nodes. A watertight case encloses each sensor node. The case has the dimensions 41x34x15mm and the total weight of a sensor node is slightly more than 20 grams.

B. Data communication

The seven sensor nodes and the data sink uses the eight available connections of the wireless body sensor network. An overview of the body area network is shown in Figure 4. The available bandwidth is 1.5Mbit/s in each direction. With a sampling rate of 1kHz there is still enough bandwidth left for retransmissions and overhead for time synchronization. To get reliable data, the time between all measurements needs to be known and as exact as possible. This means the system will have a reliable time synchronization protocol implemented. An example of such a network with low latency has been provided in an earlier work [16].

The BLE113 integrates Bluetooth radio with Smart stack and profiles. BLE stands for Bluetooth Low Energy and Bluetooth Smart is the marketing name. A low standby power and fast wake up is the reason for power saving compared to earlier Bluetooth versions. The standby power is always present and is one of the bigger parts of the total energy consumption together with for example the number of active connections [17]. The transmitting power will be adjusted to be just enough for the body network range to reduce possible interference.

Mobile telecommunication or Wi-Fi will link the data sink to a web server. Depending on the choice of wireless communication, a BLE compatible Android smartphone or myRIO (National Instruments Co., Austin, TX, USA) are suggested as data sinks.

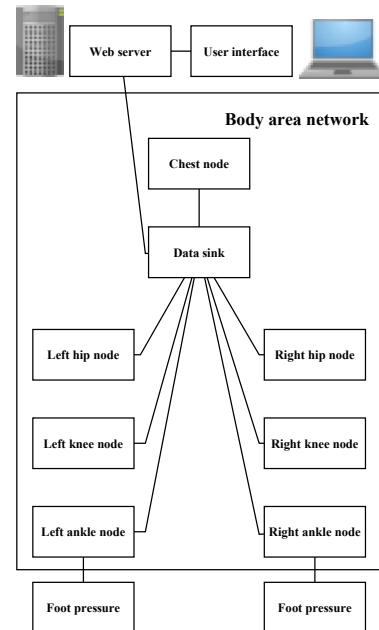

Figure 4. Body area network with 7 sensor nodes and a data sink.

C. Analysis

The main goal for the system is to check for differences in movement symmetry, so by matching periods, force and rotational velocity etc. of left and right legs it is possible to check for variance and abnormalities in this data. Interesting parameters to measure are: extremity movement symmetries, step length, velocity, peak force and the shift speed of the center of pressure.

Kalman filtration will be performed on the data gathered from the sensor nodes to remove noise and increase accuracy for the orientation data [18]. This leads to the possibility of performing better analyses of the gait symmetry. The filtrated and analyzed data will then be displayed to the user through a graphical user interface in a way that makes it easier to understand the results. There are also plans to include direct feedback options with an audio signal or vibration in the node.

D. Initial measurements

Initial measurements with the 3-axis 16-bit accelerometer and 3-axis 16-bit gyroscope have been made at 30 Hz using BGScript version 4.0 (Bluegiga Technologies Ltd., Espoo, Finland). Switching to C-programming in IAR Embedded Workbench for 8051 IDE version 8.30.3 (IAR Systems Group AB, Uppsala, Sweden) should enable a considerable increase of the sampling frequency, up to at least 1kHz.

III. DISCUSSION

In this paper, a wireless system for motion, gait and symmetry analysis has been described. A body area network with inertial measurement units and in-shoe pressure sensors is proposed.

By integrating both inertial sensors measurements and foot pressure measurements in an intelligent body area network will allow for a more adaptable and flexible system. A benefit of the system is thus that it is adjustable for various users and use cases. The number of sensors is decided by each application and the amount of transmitted data will also be adjusted for each application.

By checking for asymmetry in movement of left and right leg the system can be useful in for example fall prevention, rehabilitation, sports performance and monitoring of the amount of physical activity.

The aim was to develop a motion analysis system that could be used wherever and will not need anything else than a smartphone or PC as user interface. Depending on the application, some of the calculations can be made in the sensor nodes and the rest on the server.

Another design consideration would be to use slower sampling rates but more sensor nodes to be able to monitor the arms as well as the legs.

Technical challenges to be solved in the system are two. The first is to increasing the output rate of the motion data to 1kHz. The second is adaptable foot pressure measurements regardless of individual foot valves and shoe sizes.

However, the size and weight of the complete system is of great importance since the system must not interfere nor affect the motion itself. An even smaller and lighter sensor node format is therefore desirable.

ACKNOWLEDGMENT

This work was supported by the KKS foundation.

REFERENCES

- [1] WHO global report on falls prevention in older age. World Health Organization, 2008.
- [2] H.P. von Schroeder, R.D. Coutts, P.D. Lyden, E. Billings Jr., and V.L. Nickel, "Gait parameters following stroke : A practical assessment," *Journal of Rehabilitation Research and Development*, 1995, pp. 25-31.
- [3] L. Gonzalez-Villanueva, S. Cagnoni, and L. Ascari, "Design of a wearable sensing system for human motion monitoring in physical rehabilitation," *Sensors (Basel)*, 2013, pp. 7735-7755.
- [4] D. Benferhat, F. Guidec, and P. Quinton, "Cardiac Monitoring of Marathon Runners Using Disruption-Tolerant Wireless Sensors," *Ubiquitous Computing and Ambient Intelligence*, 6th International Conference, UCAmI, Vitoria-Gasteiz, Spain, December 3-5, 2012, pp. 395-402.
- [5] B.H. Dobkin and A. Dorsch, "The promise of mHealth: daily activity monitoring and outcome assessments by wearable sensors," *Neurorehabil Neural Repair*, 2011, pp. 788-798.
- [6] H. Sadeghi, P. Allard, F. Prince, and H. Labelle, "Symmetry and limb dominance in able-bodied gait: a review," *Gait & Posture*, 2000, pp. 34-45.
- [7] S.M.M. De Rossi, et al., "Gait segmentation using bipedal foot pressure patterns," *Biomedical Robotics and Biomechanics (BioRob)*, 2012 4th IEEE RAS EMBS International Conference on, 2012, pp. 361-366.
- [8] T.L. Lawrence and R.N. Schmidt, "Wireless in-shoe force system [for motor prosthesis]," *Engineering in Medicine and Biology Society. Proceedings of the 19th Annual International Conference of the IEEE*, 1997, pp. 2238-2241.
- [9] E. Eils, et al., "Characteristic plantar pressure distribution patterns during soccer-specific movements," *Am J Sports Med*, 2004, pp. 140-145.
- [10] C.C. Yang and Y.L. Hsu, "A review of accelerometry-based wearable motion detectors for physical activity monitoring," *Sensors (Basel)*, 2010, pp. 7772-7788.
- [11] B. Mariani, S. Rochat, C.J. Büla, and K. Aminian, "Heel and toe clearance estimation for gait analysis using wireless inertial sensors," *IEEE Trans Biomed Eng*, 2012, pp. 3162-3168.
- [12] S.J. Bamberg, A.Y. Benbasat, D.M. Scarborough, D.E. Krebs, and J.A. Paradiso, "Gait analysis using a shoe-integrated wireless sensor system," *IEEE Trans Inf Technol Biomed*, 2008, pp. 413-423.
- [13] E.S. Sazonov, G. Fulk, J. Hill, Y. Schutz, and R. Browning, "Monitoring of posture allocations and activities by a shoe-based wearable sensor," *IEEE Trans Biomed Eng*, vol. 58, pp. 983-990, 2011.
- [14] M. Chen, B.F. Huang, K.K. Lee, and Y.S. Xu, "An Intelligent Shoe-Integrated System for Plantar Pressure Measurement," *Robotics and Biomimetics. ROBIO '06. IEEE International Conference on*, 2006, pp. 416-421.
- [15] R. Lvping, et al., "Design of in-shoe plantar pressure monitoring system for daily activity exercise stress assessment," *Biomedical Engineering and Informatics (BMEI)*, 4th International Conference on, 2011, pp. 1367-1370.
- [16] M. Bergblomma, et al., "A wireless low latency control system for harsh environments," *11th IFAC Conference on Programmable Devices and Embedded Systems (Jointly with the IEEE)*, 2012, pp. 17-22.
- [17] L. Negri, J. Beutel, and M. Dyer, "The power consumption of bluetooth scatternets," *2006 3rd IEEE Consumer Communications and Networking Conference*, Vols 1-3, 2006, pp. 519-523.
- [18] L. Pei-Chun, H. Komsuoglu, and D.E. Koditschek, "Sensor data fusion for body state estimation in a hexapod robot with dynamical gaits," *IEEE Transactions on Robotics*, 2006, pp. 932-943.