

# Feasibility of Charge Transfer Based Atmospheric Ice Sensing

Taimur Rashid, Umair N. Mughal & Muhammad S. Virk

Atmospheric Icing Research Team  
 Narvik University College  
 Narvik, Norway  
 Email: unmq@hin.no

**Abstract**—The atmospheric icing parameters are being measured nowadays with the aid of more customized yet limited commercial equipment. The parameters include atmospheric ice detection, icing load and icing rate. The robustness of such equipment is usually under scrutiny when it comes to cold/harsh environment operations. This phenomenon was experienced consistently by the atmospheric icing research team at Narvik University College during data retrieval exercises from its atmospheric icing stations installed at Fargnesfjellet during 2012-13. In this paper it is aimed to address the potential feasibility to produce a robust hardware addressing the icing measurements signals, which includes instrumentation hardware giving icing indications, icing type and icing rate measurements in a single platform (not commercially available till date).

**Keywords**—Atmospheric Icing Sensor; Icing Type; Icing Rate; Charge Transfer; Zero Crossover; Cold Regions.

## I. INTRODUCTION

Charge transfer method adhere to the capacitive principle and can detect anything that is either conductive or has different dielectric properties than the sensors electrodes surroundings. Any object, conductive or non-conductive, that is brought in the vicinity of the electrode, has its own dielectric properties that will alter the capacitance between the electrode and the sensor housing and, in turn, will produce a measurable response. Also, certain sensor gauge the change by generating an electric field (e-field) and measuring the attenuation suffered by this field. The prime area of focus is to detect the ice at the first instance based on its physical properties. The measured signal is then required to be calibrated in order to achieve reasonably wide range of measurements; differentiated based on the liquid water content in the ice. This would enable to lay the foundation of measuring icing thickness and icing rate.

Atmospheric icing on structures occurs in conditions where cooling of an air mass causes super cooling of water droplets resident in the air mass. Water droplets in the earth atmosphere can remain in the liquid state at air temperature as low as  $-40^{\circ}[C]$ , before spontaneous freezing occurs [2][3]. Generally an icing event is defined as periods of time where the temperature is below  $0^{\circ}[C]$  and the relative humidity is above 95%. According to ISO 12494 standard [4], ice accretion can be defined as any process of ice build-up and snow accretion on the surface of the object exposed to atmosphere [4], [5]. Primarily Atmospheric icing can be classified in two main categories on the basis of the physical properties of atmospheric ice. These will vary depending upon the meteorological conditions and are termed as *precipitation icing* (freezing precipitation and wet snow) and *in-cloud icing* (rime/glaze, including fog). In Northern part of Europe particularly in Norway, it is primarily

freezing fog which causes ice accumulation on structures and this occurs mainly at high altitudes [6]. The ice accretion relies heavily on temperature, liquid water content and droplet size. The ice appearance and its physical properties are influenced by the atmospheric and weather conditions. Table I mentions these affecting parameters, whereas other elements such as compressive strength (yield and crushing), shear strength, etc., might describe the nature of ice accretion on the subject item exposed in the environment. The object exposed will have different ice accretion based on its dimensions and its orientation to the direction of icing wind blowing. Table I shows major outline of the basic meteorological parameters handling the ice accretion process.

TABLE I. TYPICAL PROPERTIES OF ACCRETED ATMOSPHERIC ICE [5]

Type of ice	Density (kg/m <sup>3</sup> )	Cohesion	General appearance	
			Colour	Shape
Glaze	900	strong	transparent	evenly distributed/icicles
Wet snow	300-600	weak, strong	white	evenly distributed/eccentric
Hard rime	600-900	strong	opaque	eccentric, pointing windward
Soft rime	200-600	low to medium	white	eccentric pointing windward

This paper is divided in six sections. Section II is an overview of different ice sensing techniques followed by section III, which outlines the critical reasons of system failure in cold region domains. Section IV deals with a detailed description of Charge Transfer Scheme whereas section V deals with the associated tradeoff. This paper is ended with conclusion section VI.

## II. ICE SENSING TECHNIQUES

The ISO issued in 2001 a standard for ice accretion on all kinds of structures, except for electric overhead line conductors. In this recommendation, a standard ice-measuring device is described in ISO 12494 [4] as a smooth circular cylinder having diameter of 30 mm placed vertically in the axis and rotating around the axis. The cylindrical length should be of 0.5m, but, in case of heavy ice accretion expectation, the length should be altered to 1m. If the cylinder cannot rotate freely due to wind drag, it may be provided with a motorized mechanism to force the rotation. The speed of rotation is not critical in terms of vertical collection. The vertical cylinder is not fully appropriate for freezing rain in the wet growth stage. To achieve this, it is preferred to use sets of horizontal collectors (rods), which are oriented orthogonally as in case of

Soviet standard ice collector Popov [9] or the Canadian Passive Ice Meter (PIM) as described in IEC 60826 [10]. Ice Sensing techniques come under the umbrella of icing instrumentation. To know about Ice sensing it is required to comprehend the phenomena of icing caused by the Meteorological parameters. Drage [6] describes the complexity of Meteorological Icing based on the factors such as object shape, wind speed, air temperature, liquid water content and droplet size distribution.

There is a lot of room to improve these measurements as new developments being carried out on focusing on these parameters, Makkonen [11]. Different research institutes and industries are involved in ice detection instruments manufacturing. But it is important to notice that many of them are still in the prototyping phase and few amongst those have launched their products in the market. The ISO 12494 standard ice sensor has been manufactured in one version in Swedish Combitech: automatic weighing, free rotation) and two in Finland (Digita: automatic weighing, forced rotation, Lehtonen [12], FMI: manual weighing, forced rotation). The devices/instruments identical with ISO ice collector have been used in the past at some locations as well Rothig [13]. For the purpose of the meteorological icing detection, few market systems (Rosemount Goodrich) and few prototypes are available in the name of Holo Optics, Infralytic, Vibrometer/Boschung. Also some available prototypes available for the ice rate analysis uses active infra-red techniques but the robustness and reliability of the equipment under harsh conditions is still questionable. The electrical impedance and weight measurement based icing equipment are more specialized, focusing on a specific parameter. There is a definite need of an icing system capable of measuring the instantaneous icing rate and thickness along with the ice type detection mechanism. This could provide an advantage to anticipate the ice accretion and load based on the valid detection of icing type.

### III. GENERAL REASONS OF SYSTEM FAILURE IN COLD ENVIRONMENTAL CONDITIONS

As mentioned in Rashid et. al. [26] that the dimension of operational problems faced in cold climate is quite different from the operations in normal atmospheric conditions. More often the factors not significant at all in the normal conditions become extremely critical in cold climate regions. Investigations were carried out to track down possible reasons of the HiN icing station's components failure from operational point of view. Analysis showed that in addition to the harsh weather conditions, a combination of various design and operational aspects could also lead to the system's failure in harsh conditions. Following are some noteworthy causes in this regard.

#### A. Intermittent Power Source

The system installed at the location takes power from the available commercial facility, where high load machines are being operated. Due to the demographic location of the site in terms of accessibility and complicated power infrastructure available in terms of maintenance, several power breakdowns have been frequently reported. The instantaneous power surge could be one reason that has affected the sensors operations.

#### B. Electrostatic Discharge

The electrostatic discharge phenomena could not be fully neglected in weather station breakdown. For snowstorms,

temperature gradients in the ice particles produce charge separation because the concentration of  $H^+$  and  $OH^-$  ions in ice increases rapidly with increasing temperature.  $H^+$  ions are much more mobile within the ice crystal than  $OH^-$  ions. As a result, the colder part of an ice particle becomes positively charged, leaving the warmer part charged negatively [21]. The resulting electrostatic phenomena due to blizzard can be hazardous for the control circuitry inside the sensor module, provided the said consideration is not catered for in the design. Over and above this fact, the proper maintenance of earthing at the site becomes all the more critical in this perspective.

#### C. Data Links / Interfaces Winterization

Interface links between the components are data and power based. Data links might include the Ethernet/serial links with supporting routing cables or interface panels, whereas, power links have distribution panels, supplying power requirements to the computing and sensing equipment. Interface links along with power support systems have direct and/or indirect exposure to cold climatic conditions and they are under sudden transitional states, hence are most vulnerable to degradation and failure.

#### D. Power Cable Insulation

Electrical insulation of external power cables can be another possible cause of system failure. Many of the insulations normally used on electrical wires and cables are not compatible with colder temperatures. Cracking of the insulation exposes the conductor to the environment creating a serious hazard. This is particularly a problem for the extension cords used outdoors. Several polyvinylchloride (PVC) insulations that are commonly used as electrical insulation do not withstand flexing at low temperatures, in the range of or below  $-30^\circ[C]$ , PVC insulations crack and peel off leaving exposed conductors, which can cause short circuiting or develop grounding problems making data unreliable [24], [25].

#### E. Material & Winterization

The sensitivity of problems encountered in cold regions is largely a function of materials used in the sensor construction and degree of stress, under which they are operated. Some materials get stronger at cold temperatures while other materials can be altered to become more cold tolerant [24], [22]. Similarly, sensor winterization can be another possible reason for this failure. Sensors must be properly winterized to make them possible to use during winter and reduce cold related wear and breakage [23].

### IV. CHARGE TRANSFER CAPACITANCE BASED ICE DETECTION

It can be said that a diversified sensing technique is required for ice detection, which is robust enough to face the harsh environmental conditions. The reliability and consistency of the measured results add on to the significant requirements during the measurement process. The ice detection and measurement through its capacitive properties could be a viable option in this scenario as suggested by Mughal et. al. [14]. Capacitive sensors are considered amongst the reliable and robust sensing options. A capacitive ice detector for monitoring ice formation in power lines has been reported in Michael J. Moser [17]. Furthermore, charge induction based ice detectors

is reported in [16] (mounted in the surface of the road). This ice detector can detect the presence of icing over the road/runway without measuring the icing rate and type of the ice.

To consider other viable options, proximity and touch sensing techniques can be considered. These are widely used in sensing human capacitance. Most of the daily home appliances, mobiles, industrial applications and gadgets use this detection principle as an integral part of their system design. The technique for proximity or nearness detection of human skin has matured over the years and customized microelectromechanical systems MEMS devices are available for integration as per the requirement of the design. However, use of this approach is not tested for the purpose of ice detection and has not been reported yet. This technique could be applied for ice detection including the water layer along with icing because of its advantages based on implementation flexibility and design robustness.

A. Working Principle

The nearness of the ice on the surface can be measured with the appropriate use of selection of dielectric material and charge transfer process. The field generated due to charge transfer can be thought of as a forced field applied, which ultimately can be measured in return when the presence of ice is detected on the surface. To amicably use this technique sensor’s electrode should be adequately designed for detecting the proximity of the target material with a quantified output. The field is self-generated through any type of conductive material and the response is processed in a customized way to compute the changes in the measurement. The technique can be thought of as an active measurement methodology where self-generated field is repeated to a known threshold level and de-activated to analyze the properties of the material during the silent phase field generated. The charge transfer technology can be implemented / tested for two different schemes based on capacitive sensing

- i Self-capacitance oriented
- ii Mutual capacitance oriented

In *Self-Capacitance* approach, the electrode used for sensing is a single conductive plate; second plate of capacitor is in fact the circuitry or earth ground. The sensing electrode is merely an open circuit plate or alternatively describing we can measure the self-capacitance of this plate. Electrode is underneath the dielectric panel so there is no direct galvanic connection to measuring circuit in the presence of ice or other substance. This technique is aimed to make detection measurements in case of external object presence near electrode. The detection is made because of the effect that its presence has on the capacitance of the electrode. The equivalent circuit of the self-capacitance circuit is shown in Figure 1.

Here, GND is the printed circuit board PCB ground and EARTH is earth ground. The coupling capacitance between ground and earth is few tens of pico-farad. Sampling capacitors store the charge during burst of pulses applied to the electrodes and normally have recommended values in nano-farads, which are further tuned to the design requirement to achieve larger detection threshold. Therefore, key highlights are

- Assuming  $C_s \gg C_x$ , and  $C_f \gg C_x$  and  $C_t$
- $C_x$  and  $C_t$  are of parameters of interest

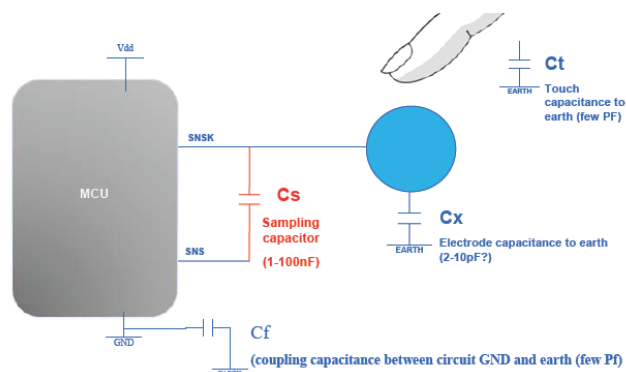

Figure 1. Self Capacitance Equivalent Circuit, [1]

- Increasing  $C_s$  = Increased differential sensitivity and makes the burst length longer and improves resolution

In Mutual capacitance approach, each sensing electrode pair contains a field drive electrode and a receive electrode as shown in Figure 2.

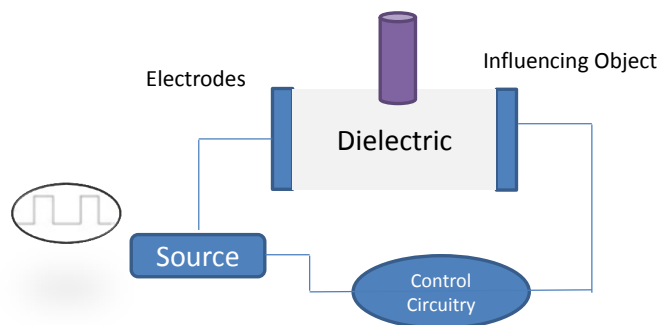

Figure 2. Ice Detection by Mutual Capacitance (Broad Scope)

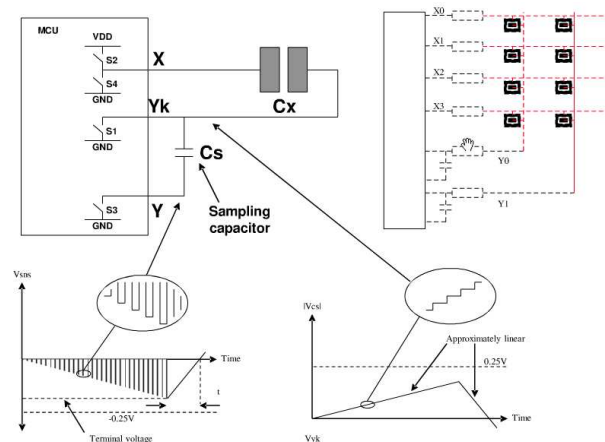

Figure 3. Mutual Capacitance Equivalent Circuit, [18]

Signal that couples through the mutual capacitance of the electrode structure is collected onto a sample capacitor, which is switched by the chip synchronously with the drive pulses.

A burst of pulses is used to improve the signal to noise ratio; the number of pulses in each burst also affects the gain of the circuit, since more pulses will result in more collected charge and hence will provide more signal [18].

By modifying the burst pulse length, the gain of the circuit can be easily changed to suit various electrode sizes, panel materials, and panel thicknesses. After the burst completes, the charge on the sample capacitor is converted using a slope conversion resistor which is driven high, and a zero crossing is detected to result in a timer value, which is proportional to the pair electrode charge coupling, which also reflects charge absorption caused by external intruding material. The presence of intruding object absorbs charge, so the measured signal decreases with its presence. The burst phase causes the charge on the sample capacitor to ramp in a negative direction, and the slope conversion causes a ramp in the positive direction on the capacitor; the net effect is that the conversion process is dual slope, and is largely independent of the value of the sample capacitor and is highly stable over time and temperature [19].

### B. Cold Climate Implications & Performance

Both capacitive mechanism are majorly comprised of electrode sets and PCB hardware. The electrode design has the flexibility to adopt any shape as it is flexible enough to be mounted on any type of support. The electrode plate can be covered with different types of dielectric material much more resistant to harsh weather and climatic effects; since there are large number of thin dielectric materials available commercially nowadays. Figure 4 shows the simple operational scheme of the overall charge transfer based icing sensor design.

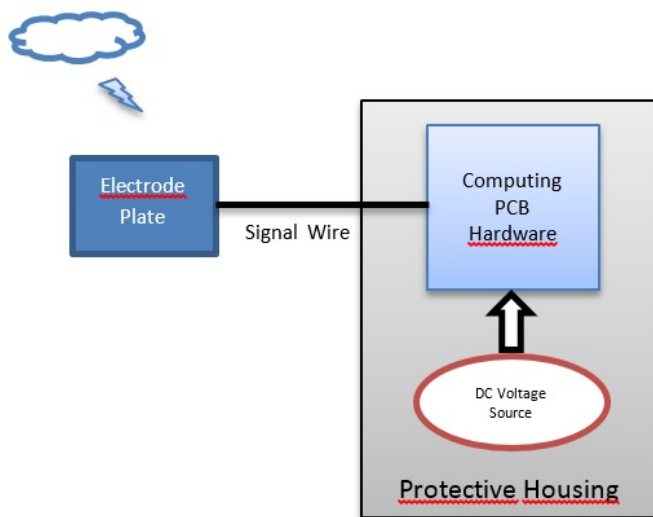

Figure 4. Operational Scheme of Charge transfer Ice sensing

The only exposed part is the electrode, which may be the copper trace on a printed circuit board covered with weather resistant dielectric material of known parameters. The weather resistant dielectric coating/covering can ensure the protection required to avoid corrosion of the plate. The low voltage requirement [milli-volts] of the MEMS devices makes the design feasible for battery operated system in a remote location.

1) *Electrode Panel Selection:* The flexibility of electrode configuration provides different schemes in terms of shapes and forms. The layout of the electrode for charge transfer scheme is focused on the maximum transferring of charge either to the adjacent electrode (receive) or provide effective ground loading. Common electrode materials include copper, carbon and silver ink. The lower the  $[\Omega/sq]$  resistivity of the material, the better as it makes control of any RC time constants (which play key role in detection measurement) much easier. The  $[\Omega/sq]$  rating choice is coupled with the shape and size of the electrode. Larger in length and thin electrodes or traces build up resistance extremely quickly, even for relatively low resistivity. Common front panel materials include glass, plexiglass and polycarbonate. The panel thickness and its dielectric constant  $\epsilon_r$  play a large part in determining the strength of electric field at the surface of the control panel.

Glass has higher  $\epsilon_r$  than most plastics as higher numbers deduce the fields to propagate more effectively. Thus a 5[mm] panel with  $\epsilon_r$  of 8 will perform similarly in sensitivity to a 2.5[mm] panel with an epsilon of 4, considering all other factors equal. A panel up to 10[mm] thick is quite usable, depending on electrode spacing and size [17]. The circuit sensitivity needs to be adjusted during development to compensate for panel thickness, dielectric constant and electrode size. With increase in thickness of material signal to noise ratio SNR worsens hence always thickness of the front panel material is to be kept small. Materials with high relative dielectric constants are also preferable for front panels as they help to increase SNR.

### V. TRADE-OFF

The self and mutual charge transfer techniques are primarily differentiated based on the electrode configuration. The single electrode and its multiple scheme implanted on a single surface adheres to ground loading influence for the measurement, which eventually will attributes to the sensitivity of the ice measurement. The main tradeoffs amongst the self and mutual capacitance techniques are sensitivity, range, noise rejection, ground loading and probability of false detection. The self-capacitance design is more sensitive in nature. The field is spreads outwards the electrode in the dielectric environment and ground loading is provided by the external influencing of the object, in our case will be ice or a water film. But with increase in sensitivity comes the inclusion of the noise in the circuitry, which is un-desirable. The noise in self capacitance might be increased so sensitivity tuning is the vital for design based on this methodology. The sensitivity in case of capacitive based design has several factors ranging from the electrodes design to the charging/discharging mechanism affecting the sensitivity of the sensor. This includes electrode dimensions and shape, ground loading, return path, supply voltage and charging pulses duration.

### VI. DISCUSSION AND CONCLUSIONS

The atmospheric icing detection and measurement in harsh cold climate is a demanding challenge. The need is more demanding with the latest developments in the high north regions to explore for energy ventures, which have initiated the infrastructure and channelizing of resources. The ice accretion and winterization factors can be very easily overlooked during the development process, which has the lasting impact in cost

related damages. Therefore, icing parameters like rate, type, thickness could play vital role in areas for instance deicing feed-back mechanism for efficient ice removal, creation of geographical ice maps of the particular region and many more. The icing parameters discussed need reliable sensing methodology for acquisition and measurement in the harsh cold regions.

A preliminary series of experimentation were performed in Cold Room Chamber of Narvik University College. The ice samples used were collected from the freezing process of the commercially available freezers. The charge transfer technique outputs zero crossover due to the dielectric variation between different samples shows clear potential this effective/potential technique for Cold Regions. The zero crossover is a real time technique and hence the delays associated with this technique are minimum. The results can be seen in Fig. 5.

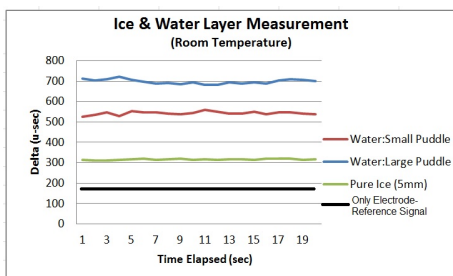

Figure 5. Ice and Water Detection Ranges

The charge transfer based techniques well known for human capacitance application can be utilized for icing rate, type and thickness. The self or mutual capacitance basics can be employed in the design based on charge transfer method. The electrode configuration schemes can be used in pairs or as an individual based on the optimum tradeoff amongst the design options. A small printed circuit board aided with the specific electrode configuration can be manufactured as a basic prototyping icing sensor. The benefit of reshaping the electrodes and design to any form with capability to change different dielectric material suitable to harsh environment can be used as a starting point to develop a robust prototype. This would enable to detect and measure the icing parameters in real time embedded platform with low power consumption; which is ideal for remote installations.

ACKNOWLEDGMENT

We acknowledge the research funding from Research Council of Norway, project no. 195153/160 and partially by the consortium of the ColdTech RT3 project - Sustainable Cold Climate Technology.

REFERENCES

[1] [http://www.ineltek.com/ru/files/Capacitive\\_Touch\\_Intro\\_2011\\_05.pdf](http://www.ineltek.com/ru/files/Capacitive_Touch_Intro_2011_05.pdf). Last accession date 23rd March 2014.  
 [2] K. F. Jones and K. Z. Egelhofer, "Computer model of atmospheric ice accretion on transmission lines", CRREL Report, 1991.  
 [3] L. J. Battan, "Cloud physics: A Popular Introduction to Applied Meteorology", Dover Publications, ISBN 978-0486428857, 2003.  
 [4] H. F. Foder, "ISO 12494 - Atmospheric icing on structures and how to use it", ISO 12494:2001, ISBN 1-880653-51-6, June 2001.

[5] S. Fikke, G. Ronsten, A. Heimo, S. Kunz, M. Ostrozlik, P. E. Persson, J. Sabata, B. Wareing, B. Wichura, J. Chum, T. Laakso, K. Santti, and L. Makkonen, "Cost 727 - Atmospheric icing on structures; measurement and data collection on icing", ISSN 1422-1381, MeteoSwiss, 2007.  
 [6] M. Drage, "Atmospheric icing and meteorological variables - Full Scale Experiments and Testing of Models", Phd Thesis, Department of Geophysics, Bergen University, Norway, 2005.  
 [7] J. Martinec, "Expected snow loads on structures from incomplete hydrological data", Journal of Glaciology, 1977, pp. 185195.  
 [8] W. Gareth, "Remote sensing of snow and ice", Chapman & Hall Publishers, ISBN 978-0415298315, 2006.  
 [9] N.I. Popov and V. V. Holodov, "On the applicability of icing measurements (in russian)", Trudy GGO 408, 1978, pp. 4448.  
 [10] , "Design criteria of overhead transmission lines", IEC 60826, 2003.  
 [11] L. Makkonen, "Analysis of rotating multicylinder data in measuring cloud droplet size and liquid water content", Journal of Atmospheric and Oceanic Technology, 9(3), 1992, pp. 258263.  
 [12] P. Lehtonen, "Experience on the iso reference collector", Experience on the iso reference collector. 8th IWAIIS, Reykjavik, Iceland, 2000, page 357.  
 [13] H. Rothig, "A device for continuous measuring and recording of ice accretion", Abhandlungen-Meteorologische Dienst DDR 107 (in German), 1973, pp. 2630.  
 [14] U. N. Mughal, T. Rashid, M. S. Virk, and P. O. Nyman, "E driven technology for Cold Regions", CogInfo Comm, ISBN 978-1-4799-1546-0/13, 2013, pp. 683686.  
 [15] J. M. Moser, B. George, and H. Z., "Icing detector for overhead power transmission lines", IEEE I2MTC, 2009, pp. 11051109  
 [16] A. Troiano, E. Pasero, and L. Mesin, "New system for detecting road ice formation", IEEE Transactions on Instrumentation and Measurement, 60(3), March 2011, pp. 1091 1101.  
 [17] <http://www.atmel.com/Images/doc10752.pdf>. Last accession date 2rd May 2014.  
 [18] [http://www.atmel.com/images/qmatrix\\_white\\_paper\\_100.pdf](http://www.atmel.com/images/qmatrix_white_paper_100.pdf). Last accession date 25th Feb 2014.  
 [19] [http://www.atmel.com/Images/qt60240\\_r8.06.pdf](http://www.atmel.com/Images/qt60240_r8.06.pdf). Last accession date 25th March 2014.  
 [20] K. B. Shraavan, U. N. Mughal, and M. S. Virk, "Experimental study of relative permittivity of atmospheric ice", International Journal of Energy and Environment, 4(3), 2013, pp. 369-376.  
 [21] J. Latham, "The electrification of snowstorms and sandstorms", Journal of Royal Meteorological Society, 90(383), January 1964, pp. 91-95.  
 [22] P. K. Dutta, "Behavior of materials at Cold Region Temperatures", U.S Army Corps of Engineers, Cold Regions of Engineering Lab (CRREL), Hanover, 1988.  
 [23] D. Diemand, "Winterization and winter operation of automotive and construction equipment", U.S Army Corps of Engineers, Cold Region Research and Engineering Lab. Hanover, 1992.  
 [24] D. R. Freitag and T. T. McFadden, "Introduction to Cold Regions Engineering", ASCE Press. 75, 1966.  
 [25] D. Rosato and R. T. Schwartz, "Environmental effects on polymeric materials", John Wiley and Sons, 1968.  
 [26] M. S. Virk, T. Rashid, U. N. Mughal, K. Zaman, and M. Y. Mustafa, "Multi Sensor Atmospheric Icing Station Performance in Cold Climate - A Case Study", The Seventh International Conference on Sensor Technologies and Applications, ISBN 978-161208-296-7, August 25-31, 2013, pp. 220:224.