

On Demonstrating Spectrum Selection Functionality for Opportunistic Networks

Alessandro Raschellà, Anna Umbert, Jordi Pérez-Romero, Oriol Sallent

Department of Signal Theory and Communications

Universitat Politècnica de Catalunya (UPC)

Barcelona, Spain

e-mail: [alessandror,annau,jorperez,sallent]@tsc.upc.edu

Abstract— This paper presents a testbed platform to demonstrate and validate spectrum opportunity identification and spectrum selection functionalities in Opportunistic Networks (ONs). The hardware component of the testbed is based on reconfigurable devices able to transmit and receive data at different operating frequencies, which are dynamically configured. The software component has been developed to perform the creation and maintenance of ON radio links, including spectrum opportunity identification and selection decision making as well as all the necessary signaling to support the ON operation. Therefore, the presented platform provides a powerful tool for testing different algorithms in real operational radio environments under various interference conditions, thus enabling to gain deeper insight into the performance of algorithmic solutions, beyond the purely theoretical analyses based on models and/or simulations. Results presented in the paper validate the implementation conducted at the laboratory and illustrate the reconfigurability capabilities of the ON links under different conditions.

Keywords-*Opportunistic Networks; Spectrum Selection; Spectrum Opportunity Identification; Testbed.*

I. INTRODUCTION

It has been stated that the Internet has been successful because of its flexibility, its accessibility via different physical media, and for its simple support of many different types of applications and data types. Initially, wired access was dominant, while the set of applications was limited mainly to file-transfer, e-mail, media streaming and client-server based web services/applications. In many positions on the Future Internet (FI), wireless access is expected to prevail, while at the same time there is growing interest for more application (deployment) areas; thus, the FI is penetrating and covering almost every facet of our lives. For instance, increasingly modern information and communication services are built around social network concepts that require smart personal devices, and this makes it even more imperative to meet the need to offer appropriate connectivity everywhere where media or data flows need to be provided. Diversified applications/services can be accessed at any time of a day, can be requested from all types of locations/environments (e.g., home, public, work, urban, rural, etc.) or by all types of communication end-points (e.g., machines, humans acting in different roles, namely in-work or private life), and can involve various information flows (voice, audio, data, images, video) and communication types (uni-cast, multicast, broadcast, peer-to-peer). In contrast to today's Internet, for the FI, it can be safely assumed that the "best effort" delivery model will not

hold. Certain applications, services and content will have to be delivered under Quality of Service (QoS) levels, or at least guaranteeing a certain Quality of Experience (QoE).

Such hard requirements will set the networks under an enormous stress for resources (bandwidth, storage processing required) in both core and access parts. Traditionally, the need for more resources has been addressed through worst-case (peak-hour) based planning. This has led to over-provisioning of resources in non-peak times. Keeping in mind that wireless resources are "expensive" (in the sense of "limited" or "scarce"), this over-provisioning will have to be tackled. In this respect, a range of solutions have been applied. For instance, many operators are aggressively adding WiFi access points and femtocell nodes to their network, in order to offload large portions of the traffic from the wide area networks of their infrastructure. However, as user behavior changes and user expectations increase, so do the resource requirements that are posed onto the communication networks. These continuously increasing requirements motivate the quest for further efficiency in resource provisioning.

Opportunistic Networks (ONs) are considered as an innovative solution to satisfy the demand for applications/services and respective resources, through increased efficiency in resource provisioning and utilization [1]. ONs are temporary, localised network segments created under certain circumstances. In this vision, ONs are always governed by the radio access network (RAN) operator (which provides the resources, the policies, the knowledge, etc.) so they can be considered as coordinated extensions of the infrastructure. ONs comprise both infrastructure nodes and infrastructure-less devices. The aim for a RAN operator to use ONs is to improve the performance of the infrastructure network, but also (and perhaps via a third party) to provide a new span of localised or closed-group services. Further on, the introduction of cognitive techniques for the management of the ONs will lead to robustness and to capitalize the learning capabilities intrinsic to cognitive systems.

ONs have been investigated to provide efficient solutions for a wide range of possible scenarios and use cases [2], such as: (1) "Opportunistic coverage extension", which describes a situation in which a device cannot connect to the operator's infrastructure, due to lack of coverage or a mismatch in the radio access technologies. The proposed solution includes an additional connected user that, by creating an opportunistic network, establishes a link between the initial device and the infrastructure, and acts as a data relay for this link. (2) "Opportunistic capacity extension", which depicts a situation

in which a device cannot access the operator infrastructure due to the congestion of the available resources at the serving access node. The solution proposes the redirection of the access route through an ON that avoids the congested network segment. (3) “Infrastructure supported opportunistic ad-hoc networking”, which shows the creation of a localised, infrastructureless ON among several devices for a specific purpose (peer-to-peer communications, home networking, location-based services, etc.). Infrastructure governs the ON creation, benefits from the local traffic offloading and develops new opportunities for service provisioning.

A common technical challenge in the different scenarios and ON use cases is to decide the proper spectrum to be used for the transmission of data and control flows in any communication link in accordance with the requirements for this link depending on the applications to be supported. This functionality is referred to as spectrum selection and it envisages a dynamic and flexible use of the available spectrum that ensures an efficient usage of this resource. The spectrum management process should be divided in two differentiated steps. First, the spectrum opportunity identification will be in charge of finding out the set of possible frequency bands that are available for the link. Second, and based on the results of the previous step, the spectrum selection will decide the most adequate band for the communication. Spectrum opportunity identification and spectrum selection functionalities have been a topic of research in different studies. For instance, [3]-[5] proposed energy detection as a means to identify spectrum opportunities, while [6]-[10] present different algorithms and protocols for assigning spectrum in cognitive radio networks.

In this context, this paper describes the testbed implementation platform that has been developed for demonstrating and validating the spectrum selection functionality in ONs. It is built based on reconfigurable devices able to operate in different frequencies dynamically configured. This allows establishing and monitoring ON radio links, and reconfiguring them based on the changes in the current spectrum conditions. In this way, the testbed provides a practical insight for testing different algorithms in real environments, going beyond the purely theoretical analyses based on models and/or simulations.

The rest of the paper is structured as follows. In Section II, the ON life cycle and functional architecture for ON management are presented. Then Section III presents the algorithmic solutions for spectrum selection considered in the testbed, and Section IV provides the testbed implementation. Section V presents some results and Section VI summarises the conclusions and next steps.

II. OPPORTUNISTIC NETWORKS: LIFE CYCLE AND FUNCTIONAL ARCHITECTURE

The life cycle of an ON comprises the following phases: (1) Suitability determination, where the convenience of setting up a new ON is assessed according to the triggering situation, previous knowledge, policies, profiles, etc., (2) Creation, which includes the selection of the optimal, feasible configuration for the new ON (selection of the

participant nodes, the spectrum and the routing pattern), (3) Maintenance, which involves monitoring and controlling the QoS of the data flows involved in the ON and performing the appropriate corrective actions when needed, and (4) Termination, when the motivations for the creation of the ON disappear or the ON can no longer provide the required QoS and, therefore, mechanisms should be provided to handle handovers and to keep applications alive if possible.

Spectrum selection is involved in all the management stages in the ON life cycle. During suitability determination, which is the result of a rough feasibility analysis in order to keep complexity moderate, there is the need to introduce mechanisms leading to the identification of spectrum opportunities that ensure that the resulting interference conditions in the possible future ON will result acceptable. The suitability stage will provide one or several possible configurations for an ON, whose feasibility and potential gains have been roughly estimated. Then, during the creation a detailed analysis (thus probably requiring additional context awareness and/or more accurate estimations related to diverse aspects of the radio environment) will be conducted and the spectrum to be assigned will be decided.

ON reconfiguration capabilities will provide the necessary adaptability to changing conditions. This stage comprises monitoring (i.e., dynamically acquire all the relevant information that may influence decision making processes around the ON such as relevant changes in the radio spectrum occupancy/interference conditions) and reconfiguration decisions. Reconfiguration decisions will be supported by other functionalities like discovery procedures for the identification of new nodes, identification of spectrum opportunities, etc.

Based on the functional architecture proposed in [11] by the European Telecommunications Standardization Institute (ETSI) for Reconfigurable Radio Systems (RRSs) an extension was proposed in [12] to deal with ON management. ON management features are attributed to an entity implemented in terminal/infrastructure. Fig. 1 depicts an example and simplified view of such management entity at the infrastructure, highlighting (1) the decision-making processes associated to the different ON stages, (2) the control mechanisms that will lead to execute the decisions taken, (3) the knowledge management module to exploit cognitive features, (4) the context awareness to provide the necessary inputs about the radio environment conditions to the decision making algorithms, and (5) the Dynamic Spectrum Management (DSM) that provides the spectrum availability conditions and related constraints to guide the spectrum selection decision making.

III. SPECTRUM SELECTION: ALGORITHMIC SOLUTIONS

From an algorithmic perspective, the problem considered in the testbed presented in this paper is the selection of the spectrum to be assigned to a set of radio links between a pair of terminals and/or infrastructure nodes. The purpose of each radio link is to support a given application with certain bit rate requirements. The spectrum selection is carried out in the decision making entity and is supported by the spectrum opportunity identification residing in the DSM module.

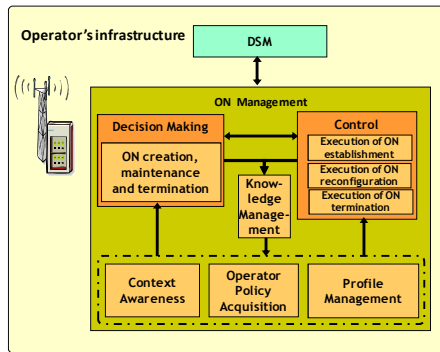

Figure 1. ON management at the infrastructure side

A. Spectrum Opportunity Identification algorithm

The spectrum opportunity identification algorithm executes two different procedures: the measurement procedure and the spectrum block formation.

In the measurement procedure, the total analysed band is subdivided into N smaller portions of equal band Δf . The measurement algorithm performs an energy detection sensing (during a period of time Δt) for each Δf portion until measuring the total band, starting from frequency F_{min_band} . This measurement is repeated Num_Meas times. Then, based on the multiple measurements carried out, the Spectrum Opportunity Index (SOI) is obtained for each portion, defined as the fraction of measurements in which this portion has been detected as available. The power threshold to decide if a portion is free is set based on [13].

In the spectrum block formation procedure, the consecutive spectrum blocks with SOI above a certain threshold are grouped in blocks. Each block is constituted by a maximum of P_{max} portions. For each block, the algorithm returns the 2-tuple $SB_k = \{f_k, BW_k\}$ where f_k is the central frequency of the block and BW_k the bandwidth.

B. Spectrum selection algorithm

The spectrum selection algorithm uses as input the set of available spectrum pools resulting from the spectrum opportunity identification, together with the characteristics of each pool in terms of available bit rate based on radio considerations. The algorithm output is the list of spectrum assignments to each of the existing links. The algorithm presented in [14] is considered for the implementation in the testbed. It makes use of the fittingness factor concept as a metric to capture how suitable a specific spectrum pool is for a specific radio link. The algorithm is based on estimating the fittingness factor for each link and available spectrum block based on a knowledge database that is maintained with different fittingness factor statistics.

IV. TESTBED IMPLEMENTATION

In this section, the testbed implementation is provided; in details, the hardware and software components and the testbed architecture are illustrated.

A. Hardware component: basic building block

The testbed demonstrator is built on the basis of Universal Software Radio Peripheral (USRP) boards. Each USRP integrated board incorporates AD/DA Converters (ADCs/DACs), a Radio Frequency (RF) front end, and a Field Programmable Gate Array (FPGA) which does some pre-processing of the input signal [15]. A typical setup of the USRP board consists of one mother board and up to four daughter boards. On the mother board, there are four slots, where up to 2 RX and 2 TX daughter boards can be plugged in. The daughter boards are used to hold the radio frequency receiver and the radio frequency transmitter. There are 4 high-speed 12-bit ADCs and 4 high-speed 14-bit DACs. All the ADCs and DACs are connected to the FPGA that performs high bandwidth math, such as interpolation and decimation. The DACs clock frequency is 128 Ms/s, while ADCs work at 64 Ms/s to digitize the received signal. A USB controller sends the digital signal samples to a PC in I/Q complex data format (4 bytes per complex sample), resulting in a maximum rate of 8 Ms/s. Consequently, the FPGA has to perform filtering and digital down-conversion (decimation) to adapt the incoming data rate to the USB 2.0 and PC computing capabilities. The maximum RF bandwidth that can be handled is thus 8 MHz.

There exist different kinds of daughter boards that allow a very high USRP reconfigurability and working at several frequency bands. The daughter boards integrated in the USRP motherboard of this testbed are *XCVR2450 Transceivers*. They work in the frequency ranges 2.4 - 2.5 GHz and 4.9 - 5.9 GHz.

B. Software Component

Identification of spectrum opportunities is performed by both a hardware platform (i.e., USRP) and a software component implemented with GNU Radio toolkit. It is a software for learning about, building and deploying software radios [16]. GNU Radio is free and open source. It provides a library of signal processing blocks and the glue to tie it all together. In GNU Radio, the programmer builds a radio by creating a graph (as in graph theory) where the vertices are signal processing blocks and the edges represent the data flow between them. All the signal processing blocks are written in C++ and Python is used to create a network or graphs and glue these blocks together. GNU Radio has been used to develop the modules that implement the algorithms described in Section III and to enable the data and control communication between USRP transceivers.

C. Testbed architecture

The objective of this testbed is to show the behaviour of the spectrum opportunity identification and spectrum selection procedures in an ON. For that purpose, a scenario is considered where two devices need to communicate through an ON link controlled by the infrastructure, as graphically illustrated in the upper part of Fig. 2. Both spectrum opportunity identification and spectrum selection functionalities reside in the infrastructure node. The result of executing these functions, with the specific frequency block assigned for the ON link between the two terminals is

notified using a Cognitive Control Channel [17].

The testbed implementation of the infrastructure node and the terminals by means of USRP transceivers is shown in the lower part of Fig. 2. USRP#1 implements the infrastructure and the associated spectrum identification and selection functionalities, while USRP#2 and USRP#3 are the terminals exchanging data. ISM 2.4 GHz band is used for the demonstration, detecting the available spectrum opportunities and allocating a portion of this band for the communication between terminals.

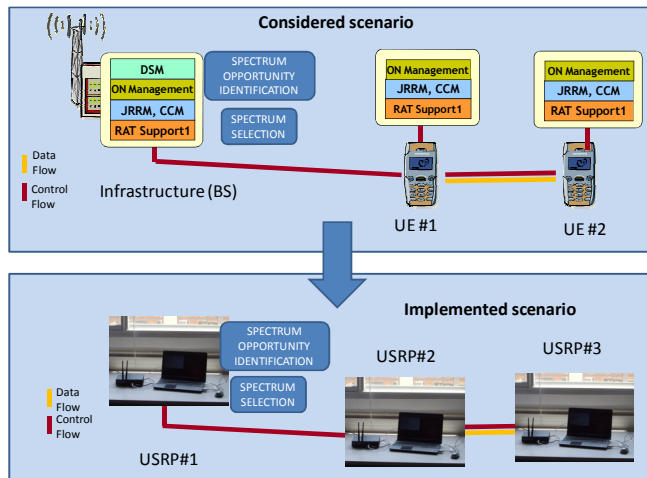

Figure 2. Scenario considered in the demonstration and corresponding implementation by means of USRP

D. Signalling procedures

Since the target of the demonstration is the spectrum opportunity identification and spectrum selection, the demonstration implements only the ON creation and ON maintenance stages of the ON life cycle. It is assumed that the decision to create an ON among the two devices has been previously made in the ON suitability phase.

The cognitive control channel signaling is implemented with the Control Channel for the Cooperation of the Cognitive Management System (C4MS) protocol using the implementation option based on IEEE 802.21 “Media-Independent Handover (MIH) Services” [18]. The implemented procedure for the ON creation is shown in Fig. 3. The steps of the procedure are explained below.

1. A MIH_C4MS_ONN.request message is sent from UE#1 to the infrastructure (Base Station - BS) to start the ON-Negotiation (ONN) procedure intended to obtain a valid configuration of the radio link. The message indicates the terminals involved and the QoS requirements that the link is expected to support, in terms of required bit rate.

2. The infrastructure sends a MIH_C4MS_ONN.request to UE#2 informing it about the intention to establish a direct radio link with UE#1 and allowing it to join the negotiation process for the derivation of the radio link configuration.

3. UE#2 replies to the BS with a MIH_C4MS_ONN.response message, notifying its acceptance for the establishment of the link.

4. The ON management entity in the infrastructure

inquires the DSM entity to determine spectrum availability for the link. The spectrum opportunity identification algorithm is executed.

5. DSM reply provides the available spectrum blocks, and the spectrum selection algorithm is executed to decide the spectrum block to be allocated to the link.

6. The proposed ON configuration with the selected spectrum is transferred to UE#1 by issuing a MIH_C4MS_ONN.response message.

7. To start the ON Creation (ONC), UE#1 sends a MIH_C4MS_ONC.request to the BS with the final ON configuration.

8. BS sends another MIH_C4MS_ONC.request towards UE#2 with the final ON configuration.

9. UE#2 replies with a MIH_C4MS_ONC.response message with a successful result-code indicating that the terminal is ready to establish the link.

10. BS concludes the ON creation procedure by sending a MIH_C4MS_ONC.response message to UE#1.

11. The link establishment takes place at this point.

12. Finally, the creation of the ON is notified to the infrastructure from UE#1 by sending a MIH_C4MS_ONSN.indication message.

A similar procedure is also implemented for the ON modification in case that degradation in the communication is perceived by one of the UEs. In this case, the procedure eventually triggers a new execution of the spectrum selection algorithm to modify the spectrum allocated to the link.

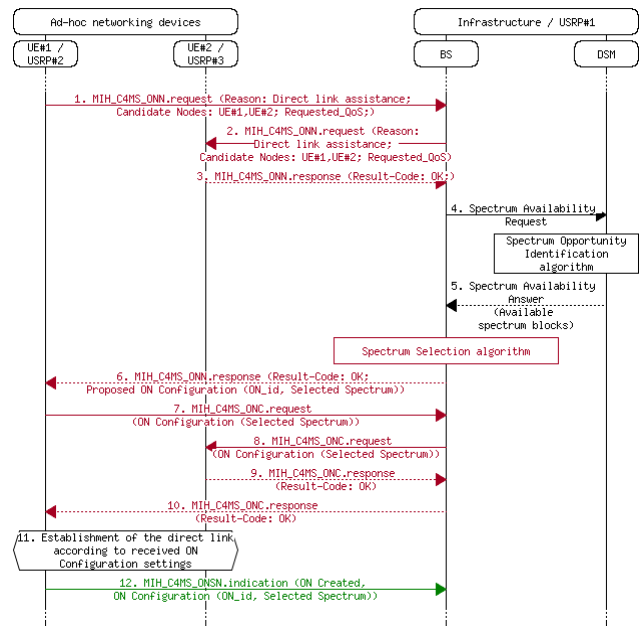

Figure 3. Implemented message exchange for the ON creation

V. VALIDATION RESULTS

In order to illustrate the testbed operation, some validation and performance results of spectrum opportunity identification and spectrum selection functionalities are presented in the following.

A. Spectrum opportunity identification

The indoor office scenario considered in this paper is illustrated in Fig. 4. The environment where the testbed operates includes the presence of two WiFi access points (AP5 and AP6) that occupy channels at 2.412 GHz and 2.432 GHz. The testbed with the ON is located in room R1.

To test the spectrum opportunity identification algorithm, the measurement procedure considered the total band from 2.4 GHz to 2.5 GHz subdivided in 1000 portions of 100 kHz. Energy detection sensing was performed for each portion during 100 ms. The threshold to detect that a portion is available is set using the following procedure: (i) the USRP antenna was replaced with a matched load (i.e., a 50 ohm resistor); (ii) the Cumulative Distribution Function (CDF) of the thermal noise was calculated; (iii) a threshold between thermal noise and signal energy was selected considering a false alarm probability equal to 1%.

Fig. 5 presents the obtained SOI for all the 1000 portions of 100 kHz averaged during a 10 minutes period. It can be observed that: (i) the spectrum portions in the ISM channels occupied by AP5 and AP6 at 2.412 GHz and 2.432 GHz, have a SOI equal to 0%; (ii) there are three groups of consecutive 100 kHz blocks with a high opportunistic index value (i.e. greater than 80%). As a result, the spectrum blocks provided by the algorithm are those indicated in Table I, considering that the maximum number of portions of a block has been set to $P_{max}=290$. Correspondingly, the available set of portions between 2442 to 2500 MHz with a total of 58 MHz has been split into 2 blocks.

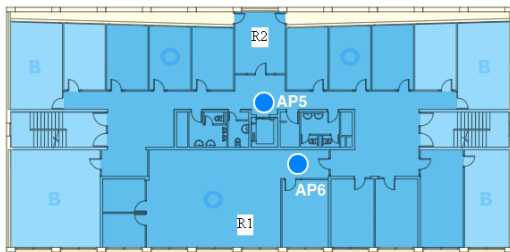

Figure 4. Considered scenario

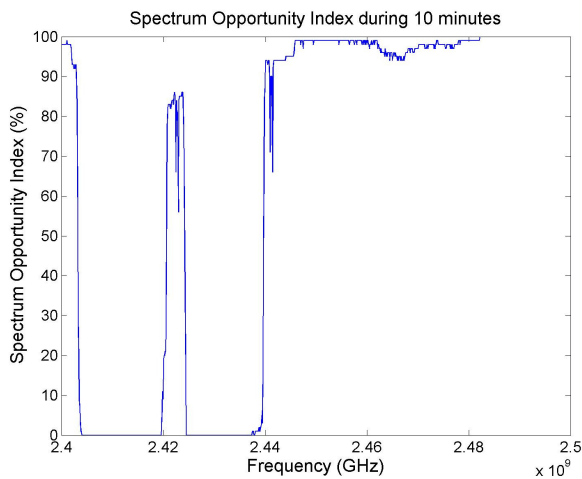

Figure 5. Spectrum Opportunity Index

TABLE I. SPECTRUM BLOCKS IDENTIFICATION

Index	Central Frequency (MHz)	Bandwidth (MHz)
1	2401.500	3
2	2422.000	4
3	2456.500	29
4	2485.500	29

B. Spectrum Selection

The aim of this subsection is to illustrate how the result of the spectrum opportunity identification is used to perform the spectrum selection functionality. In the scenario illustrated in Fig. 2, the terminals (i.e., USRP#2 and USRP#3) need a spectrum block to transmit data under the infrastructure (i.e., USRP#1) control. Following the procedure in Fig. 3, the allocated spectrum block is decided by the infrastructure during the ON-Negotiation procedure based on the spectrum opportunity identification executed by USRP#1 in the ISM 2.4 GHz band. The identification procedure is the same explained in the previous sub-section, but now averaging the measurements during a period of 10s and with $P_{max}=200$. Once the spectrum is assigned, USRP#2 is the data transmitter and USRP#3 the receiver. The experiment assumptions for the communication between terminals are given in Table II. USRP#2 periodically monitors the efficiency in the data transmission as the ratio between successfully transmitted data packets and total number of transmitted data packets including retransmissions. This is computed based on the received acknowledgements for each packet. When degradation in the communication is detected (i.e., efficiency is below the threshold of 80%), USRP#2 triggers the ON modification procedure, requesting a new spectrum block.

TABLE II. EXPERIMENT ASSUMPTIONS

Parameter	Value
Modulation	GMSK
Data Rate	256 kbps
Packet Size	1500 byte
Minimum Efficiency threshold	80%
Experiment Time	20 minutes

In the considered experiment, an additional AP has been set-up as an interference source that can be manually configured in the spectrum block allocated to the link between USRP#2 and USRP#3. Fig. 6 depicts the obtained results in one experiment. Specifically, the figure reflects the evolution of the efficiency in the communication as a function of time, in periods of 30 s. The interferer source has been activated 5 times during the experiment, leading to efficiency degradations below the threshold of 80% as can be seen in the figure. After each one of these degradations the ON modification is executed and a new spectrum block is assigned. The figure indicates the spectrum assigned to the ON link in each period of time. During the first minutes the infrastructure assigned for data transmissions the spectrum block centered at 2.422 GHz. In this period, the efficiency monitored by USRP#2 is above 80% until minute 4, when the interferer source is activated in the same frequency of the link. As a consequence, USRP#2 detects a degradation of the efficiency down to 70%. The ON modification procedure

leads to the assignment of the spectrum block centered at 2.452 GHz, with the corresponding increase of the efficiency. This process is repeated during 20 minutes demonstrating how the testbed is able to automatically reconfigure the assigned resources during changes in the interference conditions.

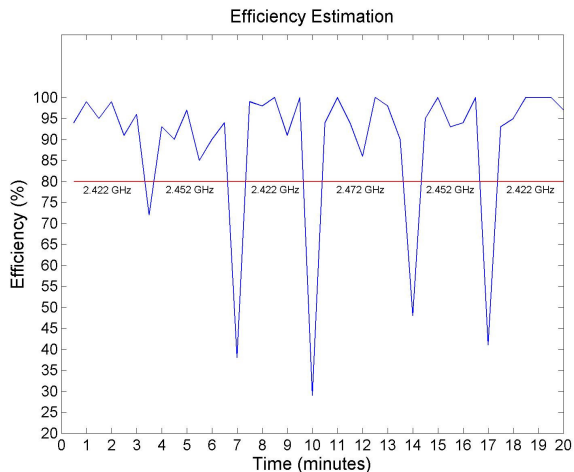

Figure 6. Spectrum Selection under changes in the interference conditions

VI. CONCLUSIONS AND NEXT STEPS

In this paper, a testbed platform has been proposed to validate the spectrum opportunity identification and spectrum selection functionalities in ON management. It is based on reconfigurable devices able to transmit and receive at different operating frequencies, and implements the necessary signaling to support ON operation. Some results have been presented to validate the implementation conducted at the laboratory and to illustrate the reconfigurability capabilities of the ON links under varying interference conditions. The developed platform constitutes a powerful tool to support the development, assessment and validation of different algorithms in real operational radio environments. Aspects related to the practicality of the algorithmic solutions can be better assessed in the testbed rather than in a simulation environment. Robustness of the proposed solutions to unpredictable radio context conditions (e.g., uncontrolled changes in the interference conditions) can also be proved in the platform. In this respect, intensive and extensive further evaluations and refinements on algorithmic solutions are expected in the near future.

ACKNOWLEDGMENT

This work is performed in the framework of the European-Union funded project OneFIT (www.ict-onefit.eu). The project is supported by the European Community's Seventh Framework Program (FP7). The views expressed in this document do not necessarily represent the views of the complete consortium. The Community is not liable for any use that may be made of the information contained herein. The work is also supported by the Spanish Research Council and FEDER funds under ARCO grant (ref. TEC2010-15198).

REFERENCES

- [1] V. Stavroulaki, et al. "Opportunistic Networks: An Approach for Exploiting Cognitive Radio Networking Technologies in the Future Internet", *IEEE Vehicular Technology Magazine*, Vol. 6, No. 3, pp. 52-59, September, 2011.
- [2] O. Moreno (editor) "Business scenarios, technical challenges and system requirements", Deliverable D2.1 of OneFIT ICT project, October, 2010, available at <http://www.ict-onefit.eu/>.
- [3] L. Catalin, K. V. Rama, A. Onur, B. Dusan, and S. Ivan, "Evaluation of energy-based spectrum sensing algorithm for vehicular networks" in *Proceedings of the Software Defined Radio and Dynamic Spectrum Access Technical Conference*, Washington, DC, December, 2009.
- [4] M. A. Sarijari, A. Marwanto, N. Faisal, S. K. S. Yusof, R. A. Rashid, and M. H. Satria, "Energy Detection Sensing based on GNU Radio and USRP: An Analysis Study"; *Malaysia Int. Conf. on Comm. (MICC)*, Kuala Lumpur, December, 2009.
- [5] R. Miller, W. Xu, P. Kamat, and W. Trappe: "Service Discovery and Device Identification in Cognitive Radio Networks", *Sustainable Development Research Network (SDRN) conference*, London, December, 2007.
- [6] Q. Zhao and A. Swami, "A Decision-Theoretic Framework for Opportunistic Spectrum Access", *IEEE Wireless Communications*, Vol. 14, No. 4, August, 2007.
- [7] H. Li, G. Zhu, Z. Liang, and Y. Chen, "A Survey on Distributed Opportunistic Spectrum Access in Cognitive Network", *Wireless Communication Networking and Mobile Computing (WiCOM)*, Chengdu, September 2010.
- [8] Q. Zhao, S. Geirhofer, L. Tong, and B.M. Sadler, "Optimal Dynamic Spectrum Access via Periodic Channel Sensing", *Wireless Communications and Networking Conference (WCNC) Hong Kong*, March 2007.
- [9] S.D. Jones, N. Merheb, and I.J. Wang, "An Experiment for Sensing-Based Opportunistic Spectrum Access in CSMA/CA Networks", *Dynamic Spectrum Access Network (DySPAN)*, Baltimore, November 2005.
- [10] L. Ma, X. Han, and C.C. Shen, "Dynamic Open Spectrum Sharing MAC Protocol for Wireless Ad Hoc Networks", *Dynamic Spectrum Access Network (DySPAN)*, Baltimore, November 2005.
- [11] ETSI, TC RRS, "Reconfigurable Radio Systems; Functional Architecture for the Management and the Control of Reconfigurable Radio Systems", TR 102 682, July 2009.
- [12] J. Gebert (editor) "OneFIT functional and system architecture", Deliverable D2.2 of OneFIT project, February, 2011, available at <http://www.ict-onefit.eu/>.
- [13] Robin I.C. Chiang, Gerard B. Rowe, and Kevin W. Sowerby, "A Quantitative Analysis of Spectral Occupancy Measurements for Cognitive Radio", *Vehicular Technology Conference (VTC) Spring*, Dublin, April, 2007.
- [14] F. Bouali, O. Sallent, J. Pérez-Romero, and R. Agustí, "Exploiting Knowledge Management for Supporting Spectrum Selection in Cognitive Radio Networks," *Cognitive Radio Oriented Wireless Networks and Communications (CROWNCOM) conference*, Stockholm, June, 2012.
- [15] <http://www.ettus.com>.
- [16] <http://www.gnuradio.org>.
- [17] ETSI TR 102 684 "Reconfigurable Radio Systems (RRS); Feasibility Study on Control Channels for Cognitive Radio Systems", April, 2012.
- [18] T. Wierzbowski (editor) "Protocols, performance assessment and consolidation on interfaces for standardization", Deliverable D3.3 of OneFIT ICT project, June, 2012.