

Analyzing the Effect of Spectrum Mobility on Mobile IPv6 in Cognitive Radio Networks

Manoj Kumar Rana
SMCC
Jadavpur University
Kolkata, India
e-mail:
manoj24.rana@gmail.com

Bhaskar Sardar
Dept of IT
Jadavpur University
Kolkata, India
e-mail:
bhaskargit@yahoo.co.in

Swarup Mandal
Delivery Head
Wipro Limited
Kolkata, India
e-mail:
swarup.mandal@wipro.com

Debashis Saha
MIS Group,
Indian Institute of
Management (IIM)
Calcutta, Kolkata, India
e-mail: ds@iimcal.ac.in

Abstract— In cognitive radio (CR) networks, the secondary users (SUs) may encounter frequent IP handoffs due to high spectrum mobility, even if they remain static spatially i.e., their network attachment does not change. However, mobile IPv6 (MIPv6) was not originally designed to deal gracefully with such handoffs induced by spectrum mobility only. As a result, the performance of the data applications running in SUs may degrade severely. This paper presents a simulation based investigation to gauge the seriousness of the issue and to suggest possible solutions. We have developed a CR Attribute Model, and implemented MIPv6 over it in the well-known simulator ns-3. For SUs, we have considered three spectrum selection strategies, namely Greedy (GDY), Most Recently Used (MRU), and Least Frequently Used (LFU). In each case, we have analyzed how the number of IP handoffs increases with rise in spectrum mobility, resulting in degraded throughput performance in SUs. Our study reveals that MIPv6 is unable to work properly in CR networks mainly due to high default values of router advertisement (RA) interval, lifetime period of care-of-address (CoA), and duplicate address detection (DAD) period. So, we need to customize MIPv6 – in terms of appropriating the pre-set values of RA interval, lifetime for CoA, and DAD period – to make it work properly in CR networks, where spectrum mobility is high.

Keywords- Cognitive Radio Network; Spectrum Mobility; IP handoff; MIPv6; Throughput; Simulation; ns-3.

I. INTRODUCTION

Recent studies have revealed that significant parts of licensed spectrums remain underutilized for long duration; the Federal Communications Commission (FCC) reported that the utilization of licensed spectrum ranges from as low as 15% to 85% [1]. To improve the spectrum utilization maximally [1], cognitive radio (CR) networks harp on dynamic spectrum allocation, permitting opportunistic access to the unused spectrum by the unlicensed users [2][3], known as *secondary users* (SUs), when subscribed customers, known as *primary users* (PUs) are not using the spectrum. SUs are equipped with cognitive capability as well as re-configurability that enable them to figure out currently unused spectrum *holes*, decide the best spectrum hole to utilize, and exploit that spectrum. SUs have the ability to detect reappearance of PUs. As soon as the presence of PU is

detected, SU evacuates the spectrum immediately and moves to another currently unused spectrum, if available. This process of switching from one spectrum to another is called *spectrum mobility/handoff* [4] by SUs.

Today, the wireless environment is highly heterogeneous, where multiple wireless access systems coexist over a certain area. If we assume that they all implement CR technology in their own spectrum [5][6], the spectrum handoff in such heterogeneous environments may give rise to two scenarios: (1) if the SU switches spectrum within the same system, only spectrum handoff occurs (which is referred to as *intra-system* spectrum handoff), (2) if the SU switches to a spectrum of a completely different system, a spectrum handoff is followed by IP handoff (which is referred to as *inter-system* spectrum handoff) [7]. Figure 1 illustrates these two types of handoffs, where dotted lines indicate only spectrum handoff and solid lines indicate spectrum handoff as well as IP handoff. Conventionally, it has been assumed that IP handoffs occur only due to spatial mobility of users in wireless networks. But, in CR networks, spectrum handoff may result in IP handoff even in absence of spatial mobility. From Figure 1, it is clear that the unavailability of unused spectrum in SU's current wireless network during spectrum mobility results into inter-system spectrum handoff that leads to an IP handoff. It is to be noted that the number of IP handoffs may be very high in case of high spectrum mobility, and so, IP handoff becomes a more common event in CR environments. This work mainly focusses on inter-system

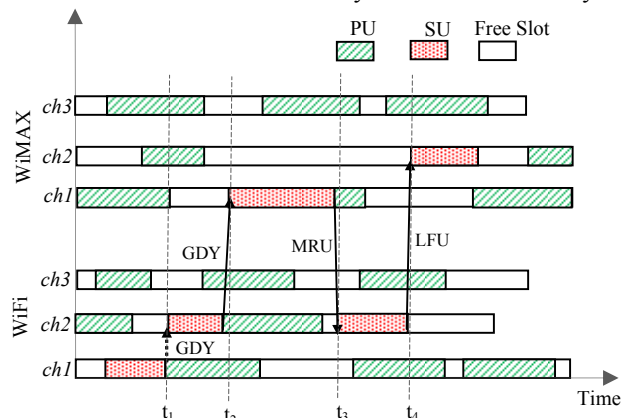

Figure 1. Spectrum mobility in CR networks

spectrum handoff.

The number of IP handoffs depends on the network parameters, such as PU arrival rate, PU channel holding time, and the number of SUs. In CR networks, the number of IP handoffs for an SU may be quite high even when the SU is stationary. In modern wireless LAN (WLAN) and Long Term Evolution (LTE) or LTE-Advanced (LTE-A) networks, the channel usage occurs in discontinuous reception mode, where a PU uses a channel for a transmission and immediately releases the channel for the transmissions from other users [8]. For instance, for data rate of 20 kbps and transmission size 1000 byte, the average channel holding time is $(1000 \times 8 / 20000) = 0.4$ sec. So, for such small PU channel holding time with significant PU arrival rate, the duration of each spectrum hole becomes very small and SU interruption frequency becomes very high. It makes the CR network environment very dynamic for the SUs. This, in turn, poses a new set of challenges for the mobile IPv6 (MIPv6) protocol [9], the de-facto standard for IP handoff management. Even if the SUs are static, they have to invoke MIPv6 to handle IP handoff triggered by spectrum mobility. MIPv6 was originally designed for handling spatial mobility only, and so is not optimized for frequent IP handoffs due to inter-system spectrum mobility. It is well known that the handoff procedure in MIPv6 takes a significant amount of time, approximately 1.896 sec to 2.47 sec [10]. So, the net temporal overhead due to multiple IP handoffs becomes very high during the complete lifetime of a data connection for an SU, which degrades the data throughput significantly, giving rise to several new issues for CR networks. Recent research works on CR networks mainly focus on reducing the spectrum handoff latency [11][12], not exploring the IP handoff issues much.

Hence, the objective of this paper is to investigate the performance of the standard MIPv6 [9] in CR networks, in particular, the effect of spectrum mobility on MIPv6. To this end, we have developed the following modules in network simulator ns-3 [13]: (1) a cognitive radio attribute module (CRAM) to simulate a typical CR network consisting of IEEE 802.11 WLAN and WiMAX, (2) three basic spectrum selection algorithms, namely greedy (GDY), most recently used (MRU), and least frequently used (LFU), (3) our own MIPv6 according to the descriptions given in RFC 6275 [9].

In the first set of simulations, our objective is to identify the issues of MIPv6 when used in CR networks. We have investigated the simulation traces and observed that the high values of router advertisement (RA) interval, lifetime of care-of-address (CoA), and duplicate address detection (DAD) timers are responsible for poor performance of MIPv6. In the second set of simulations, we have set RA interval, lifetime of CoA, and DAD timer to sufficiently small values (as deemed fit by us). Then, we have measured the number of IP handoffs and throughput performance of SUs for different spectrum selection algorithms by varying the PU arrival rate, PU channel holding time, and the number of SUs in the CR networks.

The rest of the paper is organized as follows. In Section II, we discuss recent research works on spectrum mobility and IP mobility in CR networks. Section III provides a brief

description of our model implementation in ns-3. Section IV illustrates the MIPv6 issues noted in CR networks. In Section V, we analyze the number of IP handoffs and its impact on throughput performance of the SUs. Finally, Section VI concludes the paper.

II. RELATED WORKS

To access the Internet services using CR networks, the SUs cycle through three phases: *spectrum handoff* phase, *IP handoff* phase, and *data transmission* phase. The spectrum handoff phase consists of channel sensing, handoff decision, pause, and channel switching functions [4]. Similarly, IP handoff phase consists of RA, CoA formation, and tunnel setup [9]. The phase transition is illustrated in Figure 2. During data transmission, if reappearance of PU occurs, then SU moves to channel sensing phase where the SU attempts to find spectrum holes to switch to another empty channel. If an empty channel is unavailable, the SU continues sensing the busy set of channels, repeating channel sensing and pause phases continuously. In spectrum decision phase, the SU decides the best channel to switch to, based on available channels. The selection logic is closely related to the channel characteristics, and the operations of the PUs and the SUs. In the channel switch phase, SU changes its operating channel. If the channel switch occurs in the same system, data transmission begins immediately; otherwise, the SU encounters an additional MIPv6 handoff.

Though many recent research works focus on spectrum mobility in CR networks, only a few research works focus on the resulting IP handoff and problems thereof faced by SUs.

A. Spectrum Handoff

Wang et al. [11][12] have proposed a dynamic programming based greedy algorithm to determine the optimal target channel sequence, and proved that greedy

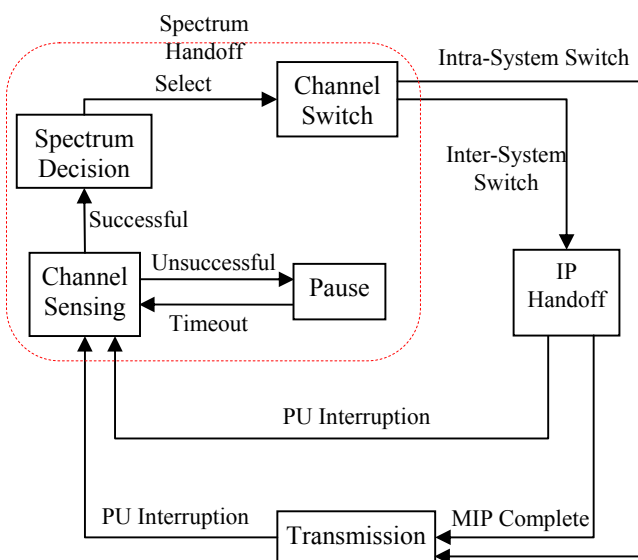

Figure 2. Mobility phase diagram in CR networks

algorithm provides better results in terms of time complexity.

To optimize the data delivery time, a traffic-adaptive spectrum handoff mechanism is proposed in [12]. It changes the target channel sequence of spectrum handoffs based on traffic conditions. Southwell et al. [14] analyzed spectrum handoff delay, considering the cost of channel switching and congestion due to multiple SUs, with prior knowledge of heterogeneous channels. They have proposed a fast algorithm to determine the best single-user decision, depending on other user's plans without communicating with each other.

B. IP Handoff

In [7], M. Kataoka et al. have proposed a MIP protocol based Cognitive Radio system architecture to reduce the handoff delay. The system architecture follows a hierarchical structure consisting of a wired and a wireless part. However, the downside of this protocol is that the control node becomes a bottleneck and may result in a single point failure. Chen et al. [15] have proposed a cross-layer protocol to optimize the data transmission time in Cognitive Radio LTE networks. Since the authors assumed homogeneous LTE network, they did not use MIPv6. Instead they used Standard LTE handoff mechanism which takes only a few milliseconds and so, there is no such noticeable impact of IP handoff in the transmission time.

The above proposals have been made to reduce the IP handoff latency in CR networks. To the best of our knowledge, no efforts have been reported thus far in the literature to investigate the issues of network layer mobility management protocols, such as MIPv6 in CR networks. Also, no prior works exist to show the impact of spectrum mobility on MIPv6. These observations call for a detailed analysis of MIPv6 in CR networks which may give us an insight into the practical design issues of MIPv6 and the impact of spectrum mobility on IP handoffs. In this paper, we have attempted to identify those issues in MIPv6 and shown that MIPv6 must be customized to work properly in CR networks.

III. COGNITIVE RADIO ATTRIBUTE MODEL (CRAM)

We have implemented CRAM in ns-3 [13]. It takes traffic parameters and spectrum selection strategy as input. We describe CRAM in the following three subsections.

A. Traffic Parameter

We consider one WLAN network with C_1 number of channels and one WiMAX network with C_2 number of channels. At any point in time, each of these channels can be occupied by a PU or a SU or remains empty. For simplicity, we have assumed homogeneous traffic parameters for all channels. Let us assume that the arrival rate of both PU and SU is Poisson. Let λ_p (arrival/second) be the arrival rate of PUs and λ_s (arrival/second) be the arrival rate of SUs. Let the service time for PUs and SUs be X_p (second/arrival) and X_s (second/arrival), respectively; both follow exponential distribution. If ρ_p and ρ_s denote the channel utilization for the transmissions of PUs and SUs, respectively, then the overall utilization is:

$$\rho = \rho_p + \rho_s \quad (1)$$

It is to be noted that $\rho \leq 1$. We denote by I_p the inter arrival time of the PUs. Due to memory less property, it follows exponential distribution with rate λ_p . As given in [12], we have,

$$E[I_p] = \frac{1}{\lambda_p} \quad (2)$$

I_p is the sum of $E[X_p]$ and spectrum hole duration. The mean spectrum hole duration $E[X_s]$ is the mean service time for the SU, i.e.,

$$E[X_s] = E[I_p] - E[X_p] \quad (3)$$

To allow the SU to utilize the channel, the spectrum hole duration must be greater than 0, i.e,

$$E[X_{SH}] > 0 \quad (4)$$

$$\text{or, } \frac{1}{\lambda_p} - E[X_p] > 0 \quad (5)$$

$$\text{or, } \lambda_p E[X_p] < 1 \quad (6)$$

The CRAM model takes C_1 , C_2 , λ_p , and $E[X_p]$ as input parameters. To obtain ρ_s we use M/M/C queuing model, where C denotes number of channels being used to serve the SUs. According to the definition of the M/M/C queue, the average number of SUs in the system can be written as [16]:

$$E[N_s] = C\rho_s + \frac{\rho_s}{1-\rho_s} D\left(C, \frac{\lambda_s}{\mu_s}\right) \quad (7)$$

where,

$$C = C_1 + C_2 \quad (8)$$

and

$$D\left(C, \frac{\lambda_s}{\mu_s}\right) = \frac{\frac{(C\rho_s)^C}{C!} \frac{1}{1-\rho_s}}{\sum_{k=0}^{C-1} \frac{(C\rho_s)^k}{k!} + \frac{(C\rho_s)^C}{C!} \frac{1}{1-\rho_s}} \quad (9)$$

Using the above formula, we can compute ρ_s , taking C and $E[N_s]$ as inputs.

B. Spectrum Selection Strategies

We have implemented three spectrum selection strategies: *Greedy* (GDY) [11][17], *Most Recently Used* (MRU) [18], and *Least Frequently Used* (LFU) [19]. These

strategies are implemented based on the statistical information of the channels. In GDY strategy, the SU selects the first empty channel without any pre-estimation of its freeness. Typically, the works [12][17] on modeling and analysis of spectrum mobility events assume GDY strategy (called first-come-first-served in their system model). The GDY strategy is an opportunistic one; it selects the empty channel at random, not targeting to utilize the spectrum holes optimally [11]. In contrast, several other research works [11][15][18][19] adopt selection strategies to utilize spectrum holes efficiently for the purpose of load balancing among channels as well as reducing data transmission time and improving throughput of SUs. These works consider the typical heterogeneous CR network environment [15] with multiple PUs and SUs [11][18][19]. We also assume this type of scenario in this work. MRU and LFU are selected as two efficient spectrum selection strategies based on the concept applied in [18] and [19], respectively. In MRU strategy, the SU selects the channel which has been used most recently by a PU, expecting a lengthy absence of PUs in that channel in near future. In LFU strategy, the SU selects the channel which has been least used by the PUs thus far, hoping that it will remain so in near future too.

In Figure 1, we have illustrated spectrum selection by a SU using these three strategies. At the time t_1 and t_2 , the SU follows the GDY strategy to switch channel. At time t_1 , the SU selects the spectrum hole of the first channel even though channel 3 is also empty. Similarly, at time t_2 , the SU selects the spectrum hole of the first channel of WiMAX network. At time t_3 , the SU follows MRU strategy and selects the spectrum hole of channel 2 of the WiFi network as it is used most currently among the free channels. At time t_4 , the SU uses LFU strategy to switch to channel 2 of WiMAX network as the usage percentage of the channel by PU is less than other free channels.

C. CRAM Implementation in ns-3 [13]

We used the *Time*, *Timer*, *Simulator*, and *RandomVariable* classes to implement CRAM. The *Time* and *Timer* classes are used to schedule a task, such as assigning a channel to a SU/PU for a particular time interval and cancel it after completion of the task. The *Simulator* class is used for initial scheduling of the entire task in the simulation, i.e., it starts the PU and SU transmissions. The *RandomVariable* class is used to generate exponentially distributed random numbers. We used two schedulers: channel scheduler (Figure 3) and SU scheduler. The channel scheduler takes the mean value of λ_p and $E[X_p]$ as input. Following the distribution, the sequence generator generates a large number of sequences (over 1000). Each sequence consists of PU service time and duration of spectrum holes. During simulation, it makes the state of the channel either *busy* or *free*, based on the generated values. In the *PU busy* state, the channel scheduler starts the PU timer and makes the state as busy. After expiration of the PU timer, the free timer starts and the channel state becomes *free*. It would remain free up to the spectrum hole duration of the current sequence unless an SU sends a busy trigger. The SU busy

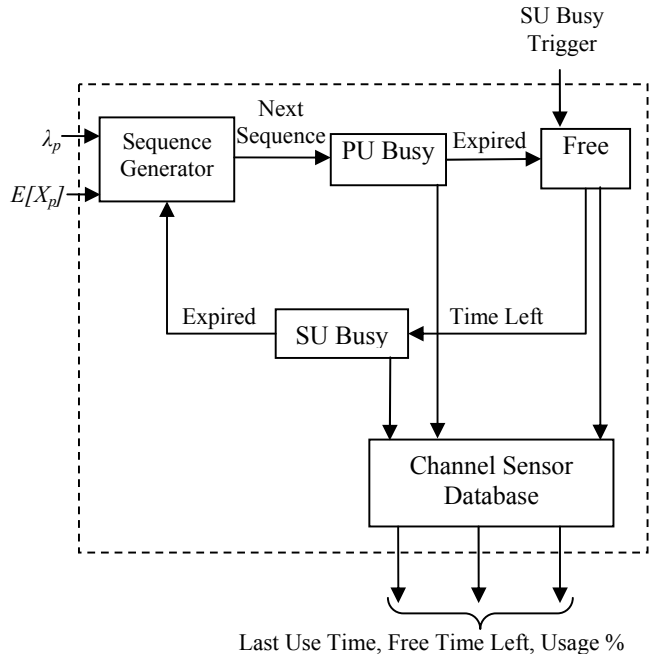

Figure 3. CRAM Channel Scheduler

trigger changes the channel state into busy. After expiration, it queries for the next sequence. A channel sensor database is designed that acquires the channel information.

In SU scheduler (Figure 4), user inputs its data transmission time and the spectrum selection strategy. The spectrum selection strategy acquires the channel information from all channels of all systems and makes a decision. It outputs the next channel number (k) and the remaining free time. If it gets the free time slot, it starts transmission timer, giving a busy trigger to the k^{th} channel scheduler. The start transmission functionality makes the SU's WiFi or, WiMAX netdevice state into 'UP'. The Stop Transmission function makes the SU's corresponding state into 'Down' state. If anytime the spectrum selection strategy cannot find a free channel, it pauses for a predefined timer value. After

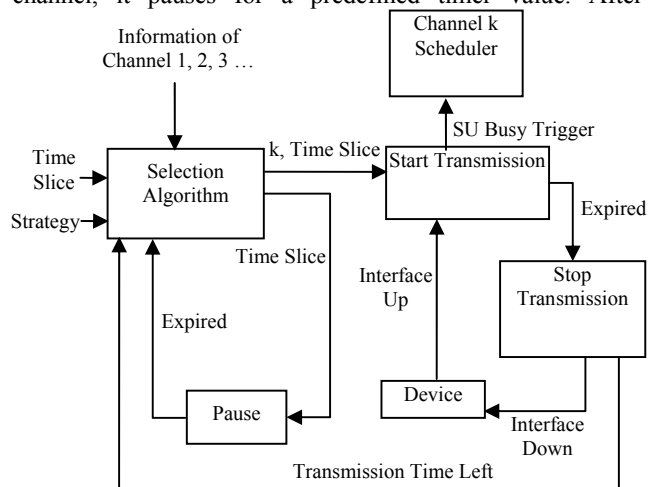

Figure 4. CRAM SU Scheduler

expiration of the pause timer, it again runs the spectrum selection strategy.

IV. MIPv6 ISSUES IN CR NETWORKS

We have developed our own MIPv6 module for ns-3 (as it is not available currently) on top of CRAM.

A. Simulation setup

We have considered a WLAN with 10 channels and a WiMAX network with 20 channels. SU is opportunistic to WLAN. We used constant position mobility model for the SUs because we are not interested in spatial mobility. We used $\lambda_p=1.5$ and $E[N_s]=4$. The average connection length is 480 bytes for exponentially distributed connections [20]. So, when the data rate of primary connection is 19.2 Kbps, we have $E[X_p]=(480*8)/(19.2*10^3)=0.2$ sec. The Pause timeout value and spectrum handoff delay are set as 0.05 sec and 0.01 sec, respectively. Correspondent node (CN) and SU are running 'UDP Echo' application and transferring packets at the rate of 80 Kbps. The whole simulation is run for 1000 sec. However, we present only the results selected from 100 sec to 200 sec to highlight the design issues.

B. High RA Interval and Lifetime Period

If the duration of spectrum holes is very small, an SU may switch from one network (say WLAN) to another (say WiMAX), reside there for a very short time, and then may return to WLAN again. When the SU switches to WiMAX, the address configured in WLAN still remains valid for some more time. If it returns to WLAN quickly, it could use the previously configured CoA in WLAN, giving rise to two issues. *First*, when the SU is in WiMAX, another SU in WLAN may configure the same CoA and execute DAD procedure. The DAD procedure detects the address as valid for obvious reasons. So, when the SU returns to WLAN quickly, duplicate addresses would exist in WLAN even if DAD procedure detects no duplicity. *Second*, the binding update and tunnel setup procedures in MIPv6 are always triggered after the completion of DAD procedure. So, if the SU uses previously configured CoA in WLAN, those procedures are skipped. Since MIPv6 is not triggered, the tunnel set up between the SU and its home agent (HA) would still be the older one and the traffic would not be redirected towards the SU. As a result, the performance of the SU degrades drastically.

In Figure 5, we illustrate the impact of high RA interval and lifetime duration on packet flow in CR networks. First, we used MaxRAInterval=3 sec and MinRAInterval=1 sec as given in [10]. So, after switching back to WLAN, the SU does not perform MIPv6 operations for a long time due to high RA interval and lifetime period. This is evident from long gaps in packet sequence number in Figure 5. Next, we decreased the values of RA interval to MaxRAInterval=0.07 sec and MinRAInterval=0.03 sec. The corresponding simulation result (Figure 5) shows that MIPv6 is unable to work gracefully, resulting in long gaps in packet sequence number. So, we further reduced the values of RA intervals to 7ms (MaxRAInterval) and 3ms (MinRAInterval), and then we found that all MIPv6 operations are completed

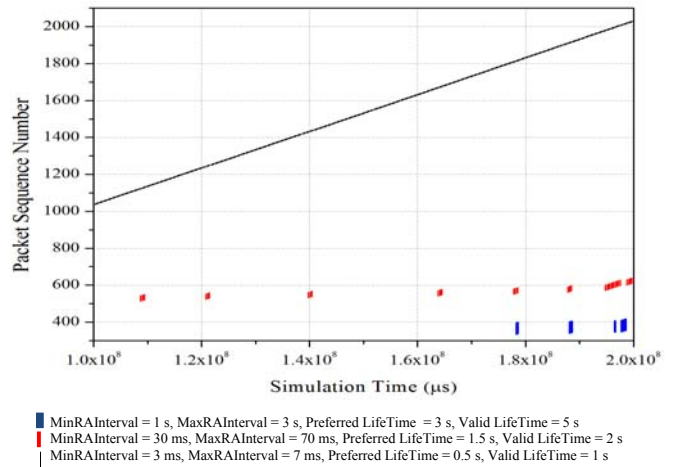

Figure 5. Behaviour under High and Low RA Intervals

successfully (Figure 5). We also observed that, under this circumstance, a large number of control packets are being generated, leading to congestion. So, we argue that the RA interval and lifetime period must be set considerably low in order to be appropriate for use in CR networks.

C. High DAD Period

RFC 6275 [9] has mentioned the default DAD period as 1 sec. It may be higher than the considered duration of spectrum holes in CR networks. Whenever an SU switches to a new network, the address configuration procedure – in particular, the DAD procedure – consumes almost the entire time, and hence, the spectrum hole cannot be used for data transmission (Figure 6). So, the throughput of SUs degrades in CR networks. For this reason, the DAD period must also be reduced to make MIPv6 more effective in CR networks.

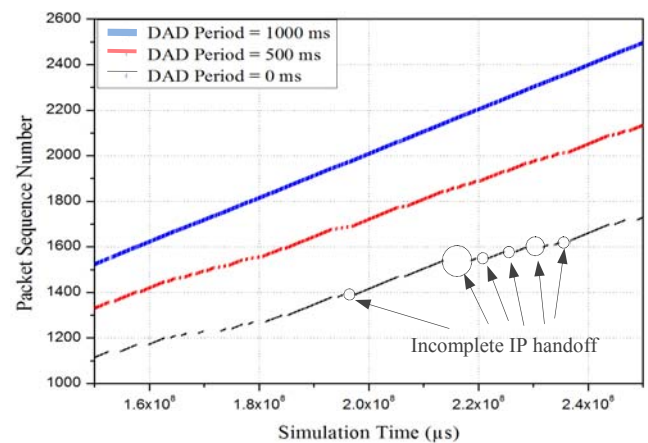

Figure 6. Behaviour under High and Low DAD Values

V. ANALYSIS OF IMPACT OF SPECTRUM MOBILITY

We have made some changes in the simulation setup, described in Section IV-A, to bring in more randomness in the availability of spectrum holes. The channels of CRAM are characterized as high usage and low usage to benefit

from LFU and MRU strategies. We used λ_p , $E[X_p]$, and $E[N_s]$ variables to control the emptiness of the channels (Table I). Also, to alleviate the problems explained in Section IV, we have taken 7 msec and 3 msec for MaxRAInterval and MinRAInterval, respectively. The preferred and valid lifetime values are assumed to be 0.5 sec and 1 sec, respectively.

TABLE I. SIMULATION PARAMETER VALUES

Variable Parameter	Other Parameter Values
λ_p	$(E[X_p])_{LOW}=0.1, (E[X_p])_{HIGH}=0.3, E[N_s]=4$
$E[X_p]$	$(\lambda_p)_{LOW}=1, (\lambda_p)_{HIGH}=1.5, E[N_s]=4$
$E[N_s]$	$(\lambda_p)_{LOW}=2.0, (\lambda_p)_{HIGH}=2.5, (E[X_p])_{LOW}=0.1, (E[X_p])_{HIGH}=0.3$

We have randomly assigned either $(E[X_p])_{HIGH}$ or $(E[X_p])_{LOW}$ values in all 30 channels, while keeping $E[N_s]=4$. Increasing λ_p , increases the frequency of spectrum holes but with reduced duration of each. From Figure 7, we observe that (i) up to $\lambda_p \leq 2.8$, the number of IP handoffs increases, (ii) for $0.1 \leq \lambda_p \leq 2.2$, all IP handoffs complete successfully due to sufficiently large spectrum holes. As a result, the throughput of the SU is reduced due to the lengthy handoff operation of Simulation Parameter Values MIPv6 as shown in Figure 8. For $2.2 < \lambda_p \leq 2.8$, only few IP handoffs were not completed due to the small duration of the spectrum holes. As a result, there was not such a drastic degradation in the throughput of the SUs as shown in Figure 8. But, for $\lambda_p > 2.8$, the spectrum holes became very small. So, the SUs could not get the opportunity to perform spectrum handoff as well as IP handoff for most of the time. In this case, SUs cycle between pause and channel sensing phases (Figure 2), thereby reducing the throughput performance of the SUs drastically (Figure 8).

For $\lambda_p \leq 2.2$, the MRU strategy performs better than LFU and GDY strategies (Figure 8) because the MRU strategy always finds the freest channel, i.e., the SU can use the channel for a long time without needing to perform frequent

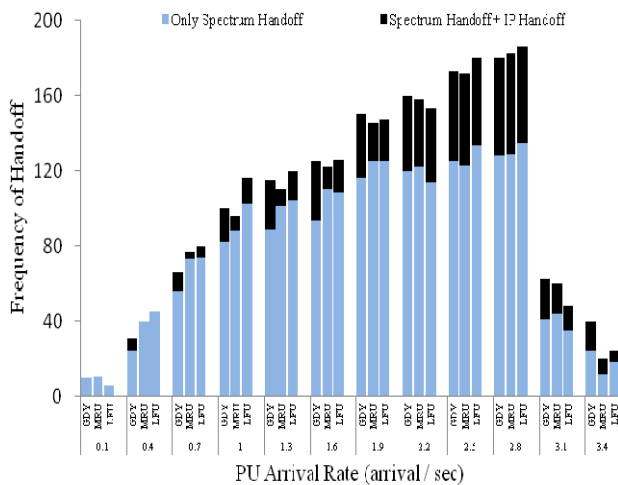

Figure 7. Variation of IP handoff with PU arrival rate

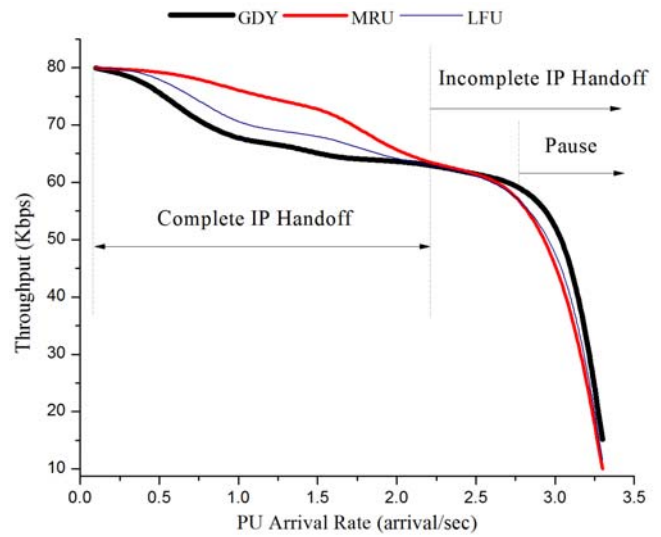

Figure 8. Effect of PU arrival rate on throughput of SU

IP handoffs. But that is not true for the other two strategies. However, for the range $\lambda_p > 2.2$, the spectrum hole duration becomes very small and is consumed by the MIPv6 handoff procedure in all the three spectrum selection strategies. In this case, since MRU always selects the longest spectrum hole, it wastes more time than the other two strategies. For $0.1 \leq E[X_p] \leq 0.4$, the number of IP handoffs was increasing. In particular, for $0.1 \leq E[X_p] \leq 0.3$, all IP handoffs were completed successfully leading to throughput degradation due to lengthy MIPv6 handoff operation (Figure 9). But, for $0.3 < E[X_p] \leq 0.4$, most of the IP handoffs were incomplete. As a result, the throughput of the SUs dropped quickly (Figure 9). Also, for $E[X_p] > 0.4$, the number of IP handoffs was reduced because the SUs were mostly cycling between channel sensing and pause phases (Figure 2). As a result, the throughput of the SUs degraded sharply (Figure 9).

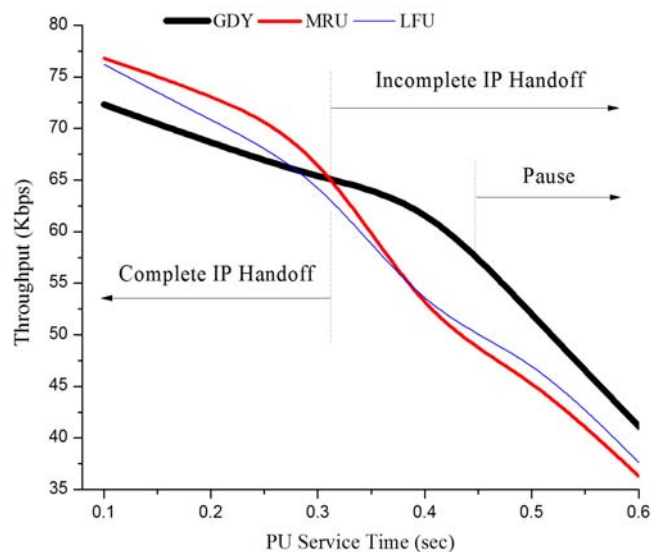

Figure 9. Impact of PU service time on throughput of SU

VI. CONCLUSION AND FUTURE WORK

Our study reveals that MIPv6 cannot work properly in CR networks due to high values of RA interval, lifetime period of CoA, and DAD period – especially when the spectrum holes are becoming smaller. So, the values for these parameters must be reduced to appropriate levels for use in CR environment. We have also analyzed the number of IP handoffs resulting from spectrum mobility in the absence of spatial mobility. Those results indicate that, unless the afore-mentioned parameters are properly tuned, the number of IP handoffs escalates with increase in the number of spectrum handoffs, resulting in severe degradation of data throughput. Also, the throughput of an SU (irrespective of the GDY, MRU or LFU strategy used) depends upon various values of the PU arrival rate and the PU service time. For lower values of these traffic parameters, MRU and LFU have better performance than GDY has; but, for higher values of the traffic parameters, GDY is better than MRU and LFU. So, in dynamic spectrum availability scenario, designing an *adaptive spectrum selection strategy* would be a good approach to enhance the overall throughput of the SU. Thus, in effect, our analyses clearly indicate that more research efforts are needed to optimize MIPv6 before it is used in CR networks.

REFERENCES

- [1] FCC, ET Docket No 03-222, 2003, Retrieved from <http://web.cs.ucdavis.edu/~liu/289I/Material/FCC-03-322A1.pdf>, January, 2016.
- [2] J. Xiao, R. Q. Hu, Y. Qian, L. Gong, and B. Wang, "Expanding LTE network spectrum with cognitive radios: From concept to implementation", *IEEE Wireless Communications*, vol. 20, no. 2, April 2013, pp. 12-19.
- [3] B. Sayrac, H. Uryga, W. Bocquet, P. Cordier, and S. Grimoud, "Cognitive radio systems specific for IMT systems: Operator's view and perspectives", *Telecommunication Policy*, vol. 37, March-April 2013, pp. 154-166.
- [4] I. Christian, S. Moh, I. Chung, and J. Lee, "Spectrum mobility in cognitive radio networks", *IEEE Communications Magazine*, vol. 50, June 2012, pp. 114 – 121.
- [5] K. -C. Chen, Y. -J. Peng, N. Prasad, Y.-C. Liang, and S. Sun, "Cognitive radio network architecture: part I -general structure", *Proc. Intl conf Ubiquitous Information Management and Commun*, January 2008, pp. 114-119.
- [6] K.-C. Chen, Y.-J. Peng, N. Prasad, Y.-C. Liang, and S. Sun, "Cognitive radio network architecture: part II - trusted network layer structure", *Proc. Intl conf Ubiquitous Info Mngmnt and Commun*, January 2008, pp. 120-124.
- [7] M. Kataoka, T. Ishikawa, S. Hanaoka, M. Yano, and S. Nishimura, "Evaluation of inter base station handover for cognitive radio", *Proceeding on IEEE Radio and Wireless Symposium*, January 2008, pp. 251-254.
- [8] J. F. Weng, B. H. Ku, J. C. Chen, and W. T. Chen, "Channel holding time of packet sessions in all-IP cellular networks", *Proc. IEEE ICPADS*, December 2014, pp. 404-411.
- [9] C. Perkins, D. Johnson, and J. Arkko, "Mobility support in IPv6", *RFC 6275, IETF*, 2011.
- [10] J. S. Lee, S. J. Koh, and S. -H. Kim, "Analysis of handoff delay for Mobile IPv6", *Proc. IEEE VTC*, vol. 4, September 2004, pp. 2967-2969.
- [11] L.-C. Wang, C.-W. Wang, and C.-J. Chang, "Optimal target channel sequence for multiple spectrum handoffs in cognitive radio networks", *IEEE Transactions on Communication*, vol. 60, September 2012, pp. 2444-2455.
- [12] L.-C. Wang, C.-W. Wang, and C.-J. Chang, "Modeling and Analysis for Spectrum Handoffs in Cognitive Radio Networks", *IEEE Transactions on Mobile Computing*, vol. 11, July 2012, pp. 1499-1513.
- [13] Network simulator (ns), version 3, Retrieved from <http://www.nsnam.org/>, January 2016.
- [14] R. Southwell, J. Huang, and X. Liu, "Spectrum mobility games", *INFOCOM, 2012 Proceedings IEEE*, March 2012, pp. 37-45.
- [15] Y. -S. Chen, C. -H. Cho, I. You, and H. -C. Chao, "A cross-layer protocol of spectrum mobility and handover in cognitive LTE networks", *Simulation Modelling Practice and Theory*, vol. 19, September 2011, pp. 1723-1744.
- [16] J. Sztrik, "Basic queueing theory", University of Debrecen, Faculty of Informatics, 2011.
- [17] C. -W. Wang, L. -C. Wang, and Adachi F., "Modeling and Analysis for Reactive-Decision Spectrum Handoff in Cognitive Radio Networks", *Proc. IEEE Global Telecommunications Conference (GLOBECOM 2010)*, December 2010, pp. 1-6.
- [18] S. -U. Yoon, and E. Ekici, "Voluntary Spectrum Handoff: A Novel Approach to Spectrum Management in CRNs", *IEEE International Conference on Communications (ICC)*, May 2010, pp. 1-5, 23-27.
- [19] G. Yuan, R. C. Grammenos, Y. Yang, and W. Wang, "Performance Analysis of Selective Opportunistic Spectrum Access With Traffic Prediction", *IEEE Transactions on Vehicular Technology*, vol. 59, no. 4, May 2010, pp. 1949-1959.
- [20] ETSI, "Universal Mobile Telecommunications System (UMTS): Selection Procedures for the Choice of Radio Transmission Technologies of the UMTS", *Technical Report UMTS 30.03*, version 3.2.0, April 1998.